

# Santa Clara City Construction Design Standards (2023 Update)



## *Special Thanks To:*

*Rick Rosenberg, Rosenberg & Associates  
Jerry Amundsen, Avenue Consultants  
Wayne Rogers, Applied Geotech  
Dave Black, Rosenberg & Associates  
Logan Blake, Planning Commissioner*

# TABLE OF CONTENTS

## SECTION 1 INTRODUCTION

1.1	Introduction.....	1-1
1.2	Definitions.....	1-1
1.3	Bonds and Insurance.....	1-6
1.4	Starting and Completing the Work.....	1-6
1.5	Before Construction Begins.....	1-6
1.6	Preconstruction Conference.....	1-6
1.7	Approved Documents Intent.....	1-7
1.8	Amending and Supplementing the Approved Drawings.....	1-8
1.9	Underground Facilities Shown or Indicated.....	1-8
1.10	Underground Facilities Not Shown or Indicated.....	1-8
1.11	Reference Points and Monuments.....	1-8
1.12	Contractors Responsibilities -Supervision and Superintendency.....	1-9
1.13	Safety and Protection.....	1-9
1.14	Site Emergencies.....	1-10
1.15	Authorized Variations in Work.....	1-10
1.16	Rejecting Defective Work.....	1-10
1.17	Warranty and Guarantee.....	1-10
1.18	Inspections and Observations.....	1-10
1.19	Contractor Employees.....	1-11
1.20	Historic, Archaeological or Paleontological Discoveries.....	1-11
1.21	Working Hours.....	1-12
1.22	Uncovering Work.....	1-12
1.23	City's Representative May Stop the Work.....	1-12
1.24	Correction or Removal of Defective Work by Contractor.....	1-12
1.25	One Year Correction Period.....	1-12
1.26	Acceptance of Defective Work.....	1-12
1.27	Correction or Removal of Defective Work by Owner.....	1-12
1.28	Work Fully Completed.....	1-13
1.29	Construction Completed Inspection.....	1-13
1.30	Final Walk Through.....	1-13
1.31	Final Inspection.....	1-13
1.32	Final Acceptance	
1.33	Suspension of Work	

## SECTION 2 GENERAL REQUIREMENTS

2.1	Introduction.....	2-1
2.2	Construction Drawings.....	2-1
2.2.1	General.....	2-1
2.2.2	Curb and Gutter, Drainage, Sidewalks and Streets.....	2-2
2.2.3	Sewer/Storm Drain.....	2-3
2.2.4	Culinary Water.....	2-3
2.2.5	Power.....	2-4
2.2.6	Secondary Water	
2.2.7	Detail Sheets.....	2-4
2.2.8	Grading Plan.....	2-4
2.2.9	General Utility Location Information.....	2-5
2.2.10	Drawing Submittals.....	2-6

2.3	Inspection, Testing and Quality Control.....	2-6
2.3.1	Requests for Inspection.....	2-6
2.3.2	Construction Completion Inspection (Final Inspection).....	2-7
2.3.3	Guarantee/Warranty.....	2-7
2.3.4	Quality Control Testing.....	2-8
2.3.5	Test Reports.....	2-8
2.4	Drawings of Record.....	2-8
2.5	Barricades and Warning Signs - Work Area Protection.....	2-8
2.5.1	General Maintenance of Traffic (MOT).....	2-9
2.6	Cooperation with Utilities.....	2-10
2.7	Cooperation Between Contractors.....	2-11
2.8	Construction Stakes, Lines and Grades.....	2-11
2.9	Use of Explosives.....	2-12
2.9.1	Permits and Blast Plan.....	2-12
2.9.2	General Blasting Criteria.....	2-12
2.9.3	Logs.....	2-14
2.10	Protection and Restoration of Property and Landscape.....	2-14
2.11	Survey Monuments.....	2-14
2.12	Hazardous Materials Discoveries.....	2-15
2.13	Improvement Sequence.....	2-15

### **SECTION 3 DESIGN STANDARDS**

3.1	Introduction.....	3-1
3.2	Street Design.....	3-1
3.2.1	Street Cross-section Standards.....	3-1
3.2.2	Roadway Network Design.....	3-1
3.2.3	Improvement Requirements.....	3-3
3.2.3.1	Curb, Gutter, and Sidewalk.....	3-3
3.2.3.2	Driveways.....	3-3
3.2.3.3	Pavement.....	3-3
3.2.3.4	Street Lighting.....	3-4
3.2.3.5	Cross Gutters.....	3-4
3.2.3.6	Disability/ADA Ramps.....	3-4
3.2.3.7	Paved Roadway Medians.....	3-4
3.2.3.8	Minimum Access.....	3-4
3.2.3.9	Drainage.....	3-4
3.2.3.10	Traffic Control Devices.....	3-4
3.2.3.11	Pavement Marking.....	3-4
3.2.3.12	Street Trees & Landscaping.....	3-4
3.2.3.13	Other Improvements.....	3-5
3.2.4	Technical Design Requirements.....	3-5
3.2.4.1	Street Grades.....	3-5
3.2.4.2	Intersections.....	3-5
3.2.4.3	Intersection Spacing.....	3-7
3.2.4.4	Maximum Design Volume.....	3-7
3.2.4.5	Cul-de-sac Streets.....	3-8
3.2.4.6	Sidewalks.....	3-8
3.2.4.7	Curb and Gutter.....	3-8
3.2.4.8	Planter Strips.....	3-8
3.2.4.9	Design Speed.....	3-8
3.2.4.10	Clear Sight Distance at Intersections.....	3-9

3.2.4.11 Vertical Alignment .....	3-9
3.2.4.12 Safe Stopping Sight Distance.....	3-10
3.2.4.13 Horizontal Curves.....	3-10
3.2.4.14 Superelevation .....	3-11
3.2.4.15 Deceleration Lanes .....	3-11
3.2.4.16 Driveway Profiles .....	3-11
3.2.4.17 Alignment and Continuity - Off-site.....	3-12
3.2.5 Pavement Structural Design .....	3-13
3.2.6 Curb Side Mailboxes .....	3-14
3.2.7 Signs and Pavement Markings.....	3-15
3.2.8 Underground Water .....	3-15
3.3 Geotechnical Study Guidelines.....	3-15
3.3.1 Geotechnical Report.....	3-15
3.4 Drainage and Flood Control Plan .....	3-18
3.4.1 General Requirements .....	3-18
3.4.2 Erosion Control.....	3-18
3.4.3 Irrigation Ditches.....	3-19
3.4.3.1. Use of Ditches.....	3-19
3.4.3.2. Irrigation Company Approval .....	3-19
3.4.4 Water Quality Control .....	3-19
3.5 Sanitary Sewer Design .....	3-20
3.5.1 Design Flows .....	3-20
3.5.2 Minimum Size and Depth .....	3-21
3.5.3 Alignment .....	3-22
3.5.4 Service Connections.....	3-22
3.5.5 Manholes.....	3-23
3.5.6 Utility Clearances.....	3-24
3.5.7 Suspended Crossings .....	3-25
3.5.8 Pressure (Force) Mains .....	3-25
3.6 Culinary Water Design.....	3-26
3.6.1 Design Flow Pressure .....	3-26
3.6.2 Flow Design Criteria .....	3-26
3.6.3 Minimum Size and Depth .....	3-27
3.6.4 Valves and Hydrants .....	3-27
3.6.5 Pressure Reducing Valves .....	3-27
3.6.5.1 Secondary Pressure Reducing Valves .....	3-27
3.6.6 Fire Hydrant Spacing and Location .....	3-28
3.6.7 Fire Flow Requirements.....	3-29
3.6.8 Miscellaneous Water System Design Criteria.....	3-29
3.6.9 Network Hydraulic Analysis .....	3-31
3.6.9.1 When Required .....	3-31
3.6.9.2 Design .....	3-31
3.6.9.3 Submittal for Review and Approval.....	3-31
3.6.9.4 Miscellaneous.....	3-32
3.6.10 Suspended Crossings .....	3-33
3.6.11 Underwater Crossings .....	3-33
3.7 Secondary Water or Wastewater Reuse Irrigation System.....	3-32
3.8 Other Utilities Systems Design .....	3-33
3.8.1 Responsibility.....	3-33

3.8.2	Streetlights.....	3-33
3.8.3	Burial of Lines.....	3-33
3.8.4	Layout.....	3-33
3.8.5	Front Lot Line Systems.....	3-33
3.8.6	Quality Control.....	3-33
3.9	Traffic Standards.....	3-33
3.9.1	Access Control.....	3-33
3.9.1.1.	General Requirements.....	3-33
3.9.2	Traffic Impact Studies.....	3-34
3.10	Survey Monumentation Standards.....	3-36
3.10.1	General Requirements.....	3-36
3.10.2	Monuments.....	3-36
3.10.3	Types of Monuments.....	3-37

## **SECTION 4 CONSTRUCTION STANDARDS**

4.1	Introduction.....	4-1
4.2	Survey Requirements.....	4-1
4.3	Earthwork.....	4-1
4.3.1	Materials.....	4-1
4.3.1.1	Excavation.....	4-1
4.3.1.2	Subsoil Reinforcement.....	4-1
4.3.1.3	Backfill.....	4-2
4.3.2	Construction Methods.....	4-2
4.3.2.1	Construction of Embankments.....	4-2
4.3.2.2	Compaction of Earth Materials.....	4-2
4.3.2.3	Subgrade Preparation.....	4-3
4.3.2.4	Construction of Nonstructural Fills.....	4-4
4.3.2.5	Retaining Walls Required.....	4-4
4.3.3	Quality Control.....	4-4
4.3.3.1	Testing.....	4-4
4.3.3.2	Acceptance.....	4-5
4.3.4	Special Requirements.....	4-5
4.4	Pipeline Construction.....	4-5
4.4.1	Materials.....	4-5
4.4.1.1	Sewer Pipe and Fittings.....	4-5
4.4.1.2	Storm Drainpipe.....	4-7
4.4.1.3	Sewer Manholes.....	4-8
4.4.1.4	Water Pipe and Fittings.....	4-10
4.4.2	Construction Methods.....	4-18
4.4.2.1	Control of Ground Water.....	4-19
4.4.2.2	Excavation for Pipelines.....	4-19
4.4.2.3	Sheeting, Bracing, and Shoring of Excavations.....	4-21
4.4.2.4	Pipe Laying and Bedding.....	4-21
4.4.2.5	Backfilling and Compaction.....	4-25
4.4.2.6	Trenches on Highways and Streets.....	4-28
4.4.2.7	Cleaning of Sanitary Sewer Lines.....	4-29
4.4.2.8	Cleaning and Disinfection of Water Systems.....	4-29
4.4.2.9	Special Requirements.....	4-30
4.4.3	Quality Control.....	4-31

4.4.3.1	Trench Backfill Moisture/density Testing .....	4-31
4.4.3.2	Sanitary and Storm Sewer Line Testing and Acceptance .....	4-32
4.4.3.3	Water System Testing and Acceptance .....	4-35
4.5	Roadway Construction .....	4-36
4.5.1	General Requirements .....	4-36
4.5.2	Construction Staking .....	4-37
4.5.3	Grade Control Systems .....	4-38
4.5.4	Geotechnical Investigation.....	4-38
4.5.5	Roadway Subgrade .....	4-39
4.5.5.1	Preparation.....	4-39
4.5.5.2	Tolerances.....	4-40
4.5.6	Subbase - Class I and Class II .....	4-40
4.5.7	Untreated Road base .....	4-41
4.5.8	CBR Test.....	4-43
4.5.9	Tack Coat .....	4-45
4.5.10	Dense-Graded Asphalt .....	4-45
4.5.10.1	Mix Design .....	4-46
4.5.10.2	Recycled Asphalt Pavement (RAP).....	4-46
4.5.10.3	Related Work .....	4-46
4.5.10.4	Asphalt Cement.....	4-46
4.5.10.5	Shipment of Asphalt Material .....	4-47
4.5.11	Hydrated Lime for Asphalt Mixture .....	4-48
4.5.12	Aggregate.....	4-50
4.5.13	Storing, Mixing and Shipping of Plant Mix Bituminous Pavements.....	4-51
4.5.13.1	Storage.....	4-51
4.5.13.2	Batch Plant Method.....	4-52
4.5.13.3	Drier-drum Method .....	4-53
4.5.14	Asphalt Concrete Surge and Storage Silos .....	4-55
4.5.15	Shipping Asphalt Mixtures .....	4-56
4.5.16	Surface Preparation for Asphalt Overlays .....	4-56
4.5.17	Adjustment of Manhole and Utility Covers.....	4-56
4.5.18	Asphalt Paving Equipment.....	4-56
4.5.19	Rollers .....	4-58
4.5.20	Weather and Date Limitations .....	4-58
4.5.21	Spreading and Finishing.....	4-58
4.5.22	Rolling and Compacting .....	4-60
4.5.22.1	Wearing Course .....	4-62
4.5.22.2	Suitability of Aggregate .....	4-65
4.5.22.3	Mix Design .....	4-65
4.5.22.4	Mixing.....	4-65
4.5.22.5	Surface Placement.....	4-66
4.5.23	Acceptance Testing Requirements and Tolerances .....	4-66
4.5.23.1	Subbase .....	4-66
4.5.23.2	Road base and Recycled Aggregate Materials (Ram) .....	4-67
4.5.23.3	Dense-graded Asphalt Pavements.....	4-68
4.5.23.4	Compaction of Dense-graded Asphalt Pavement .....	4-69
4.5.23.5	Open-graded Asphalt Wearing Course .....	4-70
4.5.23.6	Asphalt Pavement Surfaces .....	4-70

4.6 Bituminous Seal Coat (Chip Seal) .....	4-71
4.6.1 Material Specifications.....	4-71
4.6.1.1 Bituminous Material.....	4-71
4.6.1.2 Aggregate (Chips).....	4-71
4.6.2 Aggregate Quality Control .....	4-72
4.6.3 Equipment .....	4-73
4.6.3.1 Asphalt Distributor.....	4-73
4.6.3.2 Aggregate Spreader.....	4-74
4.6.3.3 Rollers.....	4-74
4.6.3.4 Dump Trucks.....	4-74
4.6.3.5 Front End Loaders .....	4-74
4.6.3.6 Power Brooms.....	4-74
4.6.4 Bituminous Chip Seal Construction Methods .....	4-74
4.6.4.1 Surface Preparation .....	4-74
4.6.4.2 Asphalt Application.....	4-75
4.6.4.3 Aggregate Spreading .....	4-75
4.6.4.4 Aggregate Compaction .....	4-76
4.6.4.5 Loose Aggregate Removal.....	4-77
4.6.4.6 Sanding.....	4-77
4.6.4.7 Appearance.....	4-77
4.6.4.8 Weather Limitations .....	4-77
4.7 Asphalt Emulsion Seal Coat (Slurry Seal) .....	4-77
4.7.1 Material Specifications.....	4-77
4.7.1.1 Asphalt Emulsion .....	4-77
4.7.1.2 Aggregate.....	4-78
4.7.1.3 Filler .....	4-78
4.7.1.4 Set Control Additive .....	4-78
4.7.1.5 Water .....	4-81
4.7.2 Material Quality Control .....	4-81
4.7.2.1 Sampling and Testing .....	4-81
4.7.2.2 Job Mix Design.....	4-81
4.7.3 Equipment .....	4-81
4.7.3.1 Slurry Mixing Machine.....	4-81
4.7.3.2 Slurry Spreader .....	4-82
4.7.3.3 Surface Cleaning Equipment.....	4-82
4.7.3.4 Auxiliary Equipment .....	4-82
4.7.4 Asphalt Emulsion Slurry Construction Methods.....	4-82
4.7.4.1 Resident Notification .....	4-82
4.7.4.2 Vehicle Removal .....	4-82
4.7.4.3 Preparation of Surface .....	4-83
4.7.4.4 Cleaning Streets.....	4-83
4.7.4.5 Sewer Manhole Lids and Water Valve Covers .....	4-83
4.7.4.6 Test Section .....	4-83
4.7.4.7 Water Fog .....	4-84
4.7.4.8 Preparation of Slurry .....	4-84
4.7.4.9 Application of Slurry .....	4-84
4.7.4.10 Handwork.....	4-84
4.7.4.11 Joints.....	4-84
4.7.4.12 Curing .....	4-85

4.7.4.13. Weather Limitations .....	4-85
4.8 Concrete Work.....	4-85
4.8.1. Materials.....	4-85
4.8.1.1 Portland Cement Concrete Material .....	4-85
4.8.1.2 Concrete Reinforcing Materials .....	4-91
4.8.1.3 Curb, Gutter, Sidewalk and Base Materials.....	4-92
4.8.2. Construction Methods and Equipment.....	4-93
4.8.2.1 General Concrete Placement .....	4-93
4.8.2.2 Concrete Reinforcement Installation .....	4-95
4.8.2.3 Curb, Gutter, and Sidewalk Concrete Placement.....	4-96
4.8.2.4 Concrete Base Materials Placement.....	4-99
4.8.3. Quality Control.....	4-99
4.8.3.1 Concrete Testing .....	4-100
4.8.3.2 Concrete Base Material Testing .....	4-100
4.8.3.3 Acceptance.....	4-101
4.9 Restoration of Existing Surface Improvements.....	4-101
4.9.1 Introduction.....	4-101
4.9.2 Gravel Surfaces.....	4-102
4.9.3 Bituminous Surfaces.....	4-102
4.9.4 Concrete Surfaces.....	4-103

## **SECTION 5 SIGNING AND PAVEMENT MARKINGS**

5.1 Introduction.....	5-1
5.2 Signing Materials, Fabrication and Placement .....	5-1
5.2.1 Street Name Signs .....	5-1
5.2.2. Traffic Signs.....	5-1
5.2.3 Visibility.....	5-1
5.3 Pavement Markings.....	5-1
5.3.1 Line Types.....	5-2
5.3.2 Pavement Word and Symbol Markings .....	5-2
5.3.3 Traffic Paint .....	5-2
5.3.4 Temporary Markings.....	5-2

## **SECTION 6 STREET LIGHTING (Later date/Power Dept.)**

6.1 Introduction.....	6-1
6.2 Streetlight Pole .....	6-1
6.3 Subdivision Ordinance Section 8-130 Street Lights and Security Lights .....	6-1

## **SECTION 7 POWER SYSTEM (Later date/Power Dept.)**

7.1 Introduction.....	7-1
7.2 Electric Services .....	7-1
7.2.1 Power Connection .....	7-1
7.2.2 Electric Service Agreement .....	7-1
7.2.3 Customer Service Facilities .....	7-1
7.3 Materials and Workmanship .....	7-2
7.4 Control of Groundwater .....	7-2
7.5 Excavation and Backfill.....	7-2
7.6 Concrete.....	7-2



7.7 Meters .....	7-3
------------------	-----

## LIST OF TABLES

Table 3.1 Street Cross-section Configurations .....	3-3
Table 3.2 Facility Type- Access Distance from Corner .....	3-6
Table 3.3 Design Speed .....	3-9
Table 3.4 Sight Distance at Intersections .....	3-9
Table 3.5 Safe Stopping Sight Distance .....	3-10
Table 3.6 Horizontal Curves .....	3-11
Table 3.7 Driveway Type/Street Classification .....	3-12
Table 3.8 Sanitary Sewer Design Flows .....	3-20
Table 3.9 Sanitary Sewer Minimum Slopes .....	3-21
Table 3.10 Sanitary Sewer Laterals .....	3-23
Table 4.1 Sewer Pipe Dimensions .....	4-6
Table 4.2 General Pipe Requirements .....	4-11
Table 4.3 Corporation Stops .....	4-15
Table 4.4 Meter Box and Lid Size .....	4-15
Table 4.5 Backfill Material .....	4-21
Table 4.6 Air Testing .....	4-33
Table 4.7 Exfiltration Test .....	4-34
Table 4.8 Minimum Roadway Structural Requirements .....	4-39
Table 4.9 Subbase Aggregate Gradation .....	4-41
Table 4.10 Road Base Aggregate Gradation .....	4-43
Table 4.11 Paving Grade Liquid Asphalt Requirements .....	4-47
Table 4.12 Marshall Design Requirements .....	4-49
Table 4.12a Minimum Percent Voids in Mineral Aggregate (VMA) .....	4-50
Table 4.13 Dense-graded Asphalt Aggregate Gradation .....	4-51
Table 4.14 Climate Limitations .....	4-58
Table 4.15 Rubberized Liquid Asphalt Requirements .....	4-64
Table 4.16 Sieve Size and Deviation .....	4-67
Table 4.17 Sieve Size and Deviation .....	4-68
Table 4.18 Bituminous Material .....	4-71
Table 4.19 Gradation of Aggregate for Chip Seal Coats .....	4-72
Table 4.20 Slurry Seal Test Specifications - Tests of Emulsions .....	4-79
Table 4.21 Slurry Seal Test Specifications - Tests of Residue .....	4-79
Table 4.22 Slurry Seal Test Specifications - Tests on Slurry Seal Job Mixture .....	4-80
Table 4.23 Slurry Mixture Gradation .....	4-80
Table 4.24 Fine Aggregate .....	4-86
Table 4.25 Fine Aggregate Gradation Requirements .....	4-86
Table 4.26 Coarse Aggregate .....	4-87
Table 4.27 Coarse Aggregate Gradation Requirements .....	4-87
Table 4.28 Concrete Mix Specifications .....	4-91
Table 4.29 Synthetic Reinforcing Fibers .....	4-92
Table 4.30 Reinforcing Bar Clearance .....	4-96

## SECTION I

### INTRODUCTION

**1.1 INTRODUCTION.** This section contains the general conditions and instructions for development and other related construction of infrastructure improvements within the City of Santa Clara. It sets forth the conditions by which this work will take place. It also sets forth the duties, responsibilities, and obligations for the construction of improvements. These conditions apply to all development related work.

**1.2 DEFINITIONS.** Wherever used in these specifications the following terms have the meanings indicated, which are applicable to both the singular and plural thereof.

1. **AASHTO:** The American Association of State Highway and Transportation Officials.
2. **ACCESS:** An intersection or driveway that connects with a public roadway to provide ingress and egress to a property or parcel of ground, whether public or private.
3. **ACTIVE TRANSPORTATION:** Any self-propelled, human-powered mode of transportation, such as walking or bicycling.
4. **ANSI:** The American National Standard Institute.
5. **APPROVED DOCUMENTS:** The approved drawings, standard specifications, standard drawings, and any other approved supplemental specifications and conditions.
6. **APPROVED DRAWINGS:** The graphic and pictorial portions of the approved documents approved by the City's Representative showing the design, location, and dimensions of the work, and generally include: the plan, profiles, elevations, cross sections, details, schedules, and diagrams, etc.
7. **ASTM:** The American Society for Testing Materials.
8. **AWWA:** The American Water Works Association.
9. **BACKFILL:** Any earth that has been excavated from a trench or other excavation and then replaced and compacted with existing or imported material.
10. **BENCHMARK:** A surveyor's mark made on a stationary object of previously determined position and elevation and used as a reference point for surveys or other applicable points.
11. **BONDS:** An instrument of security submitted by the owner and approved by

the City to guarantee and/or warranty the required improvements.

12. **CITY:** The City of Santa Clara, Utah, a governmental entity having authority to adopt and enforce ordinances.
13. **CITY ENGINEER:** The officially appointed Professional Engineer designated as the “City Engineer” to act on behalf of and for the City of Santa Clara. May also refer to the City Engineer’s designated representative.
14. **CITY’S REPRESENTATIVE:** The person designated to act for and on behalf of the City of Santa Clara.
15. **CITY SURVEYOR:** The officially designated Professional Surveyor who acts in the capacity as the City Surveyor.
16. **CONTRACTOR:** The person, firm, or corporation with whom the owner has entered into an agreement to construct the necessary work.
17. **CUSTOMER:** One for whom city related services are rendered.
18. **DECELERATION LANE:** An auxiliary lane, independent from through traffic lanes, which is developed to allow turning vehicles to reduce their speed when approaching a driveway or intersection.
19. **DEFECTIVE WORK:** The work that is unsatisfactory, faulty, or deficient, does not conform to the approved documents, does not meet the requirements of any inspection, reference standard, test or approval referred to in the approved documents, or has been damaged prior to the City Representative’s final inspection.
20. **DEVELOPER:** The authority, corporation, association, or firm which undertakes the development or subdivision of land or properties and with whom the Contractor has entered into an agreement and for whom the work is to be provided.
21. **DEVELOPMENT:** The process of constructing a building or group of buildings for residential, commercial, industrial, or other uses or the general changing of land or property into something other than its current or natural state or condition.
22. **DRAWING OF RECORD:** The drawing(s) or plan(s) which show the locations and dimensions of constructed facilities, based on actual measurements taken in the field, as governed by City policy and ordinances.
23. **EMBANKMENT:** Any raised area of compacted earth used to support a roadway, curb and gutter, sidewalk, trail, structure, parking lot, etc. Material used for an embankment will be specified and tests will be performed to determine the material’s adequacy for the specific project.

24. **CITY:** The City of Santa Clara, Utah, a governmental entity having authority to adopt and enforce ordinances.
25. **CITY ENGINEER:** The officially appointed Professional Engineer designated as the “City Engineer” to act on behalf of and for the City of Santa Clara. May also refer to the City Engineer’s designated representative.
26. **CITY’S REPRESENTATIVE:** The person designated to act for and on behalf of the City of Santa Clara.
27. **CITY SURVEYOR:** The officially designated Professional Surveyor who acts in the capacity as the City Surveyor.
28. **CONTRACTOR:** The person, firm, or corporation with whom the owner has entered into an agreement to construct the necessary work.
29. **CUSTOMER:** One for whom city related services are rendered.
30. **DECELERATION LANE:** An auxiliary lane, independent from through traffic lanes, which is developed to allow turning vehicles to reduce their speed when approaching a driveway or intersection.
31. **DEFECTIVE WORK:** The work that is unsatisfactory, faulty, or deficient, does not conform to the approved documents, does not meet the requirements of any inspection, reference standard, test or approval referred to in the approved documents, or has been damaged prior to the City Representative’s final inspection.
32. **DEVELOPER:** The authority, corporation, association, or firm which undertakes the development or subdivision of land or properties and with whom the Contractor has entered into an agreement and for whom the work is to be provided.
33. **DEVELOPMENT:** The process of constructing a building or group of buildings for residential, commercial, industrial, or other uses or the general changing of land or property into something other than its current or natural state or condition.
34. **DRAWING OF RECORD:** The drawing(s) or plan(s) which show the locations and dimensions of constructed facilities, based on actual measurements taken in the field, as governed by City policy and ordinances.
35. **EMBANKMENT:** Any raised area of compacted earth used to support a roadway, curb and gutter, sidewalk, trail, structure, parking lot, etc. Material used for an embankment will be specified and tests will be performed to determine the material’s adequacy for the specific project.
36. **ENGINEER:** A Civil Engineer registered with the Utah Division of

Professional Licensing and licensed to practice as a Professional Engineer in the State of Utah.

37. **FILL:** Any material used to fill a depression, hole, or any other anomaly in the ground. Material used for the fill will be specified and tests will be performed to determine the material's adequacy for the specific project. An embankment is a type of fill.
38. **FINAL ACCEPTANCE:** Satisfaction on the part of the City's Representative that all work is fully complete and there are no other obligations to be fulfilled by the Contractor or the Developer.
39. **FINAL INSPECTION:** An inspection of the work which is conducted by the city's representative(s) and other necessary parties, after having said the work is fully completed.
40. **FIRE CHIEF:** The officially appointed person designated as the City Fire Chief for the City of Santa Clara or designated representative.
41. **FLOOD PLAIN:** That area of a channel, river or other water course and the adjacent land areas which are inundated during abnormally high water (flooding) generally associated with a 100-year or 500-year flood event.
42. **FLOOD WAY:** The area of the flood plain that is or must be reserved in order to pass the 100-year flood event in accordance with applicable regulations and which will not be encroached upon by construction, fill or other development.
43. **GEOTECHNICAL ENGINEER:** That Professional Engineer registered with the Utah Division of Professional Licensing and licensed to practice as a Professional Engineer in the State of Utah specializing in Geotechnical investigations which has been retained to investigate soil and other similar conditions and submit recommendations and/or reports concerning said conditions.
44. **HILLSIDE DEVELOPMENT STANDARDS:** The standards as noted in the City of Santa Clara Hillside Ordinance used in all hillside overlay zones.
45. **INSPECTION PUNCH LIST:** A written list of work discrepancies and deficiencies compiled by the City's Representatives and others during a final or other inspection.
46. **I.T.E.:** The Institute of Transportation Engineers.
47. **TECHNICAL REVIEW COMMITTEE (TRC):** A formal group of representatives from public and private utility companies in the Santa Clara area that meet as needed to review and approve utility plans as required.
48. **LAWS AND /OR REGULATIONS:** Any federal, state, county, city, or local

jurisdiction's laws, rules, regulations, ordinances, codes, and orders.

49. **LOW IMPACT DEVELOPMENT (LID):** The term referring to systems and practices that use or mimic natural processes that result in the infiltration, evapotranspiration, or use of stormwater to protect water quality and associated aquatic habitat.
50. **MAXIMUM DRY DENSITY:** The Maximum Dry Density as determined by ASTM Standard D-1557.
51. **MAINTENANCE OF TRAFFIC (MOT):** A process of establishing a work zone, providing related transportation management and temporary traffic control on city street and highways.
52. **MUTCD:** The Manual of Uniform Traffic Control Devices, latest edition and revisions as published by the U.S. Department of Transportation, Federal Highway Administration.
53. **OWNER:** The authority, corporation, association, or firm with whom the Contractor has entered into an agreement and for whom the work is to be provided. This can refer to the Developer or the Owner of the property being developed.
54. **OWNER'S ENGINEER (OR THE ENGINEER):** The professional engineer or engineering firm (registered with the Utah State Department of Business Regulation) which has been retained by the Owner to produce plans, specifications, oversee work, etc. required by the Owner in the prosecution of the development of said Owner's properties. (See engineer).
55. **OWNER'S REPRESENTATIVE:** The person, firm, or corporation designated to act for and on behalf of the owner.
56. **PLANS (DRAWINGS):** The graphic and pictorial portions of the documents approved by the City's Representative showing the design, location, and dimensions of the work, which generally include all details, schedules and diagrams required for construction of the project.
57. **POINT OF CURVATURE:** The point at which the alignment of a roadway, curb, gutter, sidewalk, or lot line changes from a straight line, or tangent, to a circular curve. For example, as a curb and gutter run approaches an intersection with an adjoining roadway, where the curb and gutter begins to curve to intersect the curb and gutter of the adjoining roadway.
58. **POWER DEPARTMENT:** Refers to the City of Santa Clara Power Department.
59. **PRIVATE IMPROVEMENTS:** The work or improvements which are undertaken by the Owner or Developer for the benefit of a select group of private individuals, which are not maintained or repaired by the city and are not dedicated to the city for public use.

60. **PROJECT:** The total work to be provided under the approved documents.
61. **PROFESSIONAL TRAFFIC OPERATIONS ENGINEER (PTOE):** A professional engineer further certified in the practice of traffic engineering.
62. **PUBLIC IMPROVEMENTS:** The work or improvements which are dedicated to and maintained by the city for the benefit of the Public-at-large.
63. **SHOP DRAWINGS:** All drawings, diagrams, illustrations, schedules, and other data prepared by or for the Contractor to illustrate some portion of the work as well as all illustrations, brochures, standard schedules, performance charts, instructions, diagrams, and other information prepared by suppliers and submitted by the Contractor to illustrate material or equipment required for some portion of the work.
64. **SOILS REPORT (GEOTECHNICAL INVESTIGATION REPORT):** The report produced by the Owner's Geotechnical Engineer and submitted to the city. It shall describe the existing conditions for the foundation soil of the land being considered for development by the Owner. The said report also sets forth that the said Engineer's recommendations concerning the requirements of the said soils for the intended use. (A soils report is the same as a Geotechnical report).
65. **SPECIFICATIONS:** Those portions of the approved documents consisting of these Standard Specifications as well as other requirements for materials, equipment, construction systems, standards, and workmanship, as applied to the work and certain applicable administrative details.
66. **STANDARD SPECIFICATIONS:** The specifications contained in these documents.
67. **STREET NAME SIGNS:** Public and private signs indicating the street name, address coordinate, type of road, color designation, or combination thereof.
68. **STRUCTURAL ENGINEER:** The Professional Engineer or engineering firm specializing in structural engineering and design, which has been retained to design and engineer the structural elements required in the project under consideration.
69. **SUBCONTRACTOR:** An individual, supplier, firm, or corporation having a contract with the Contractor or with any other subcontractor for the performance of any part of the work.
70. **SUBGRADE:** Subgrade shall refer to the native, prepared original soil or engineered fill under any roadway, fill, embankment, structure, etc.

71. **SUPPLEMENTARY CONDITIONS:** The part of the approved documents which amends or supplements the Standard Specifications.
72. **SUPPLIER:** A manufacturer, fabricator, distributor, material producer, or vendor.
73. **SURVEYOR:** An individual registered with the Utah State Department of Business Regulation and licensed to practice as a Professional Land Surveyor in the State of Utah.
74. **TIS:** The Traffic Impact Study which may be required by the city and furnished by the Traffic Engineer for and on behalf of the Owner/Developer in accordance with all applicable standards and requirements of the City.
75. **TRAFFIC SIGNS:** All regulatory, warning, advisory, informational, and other roadside traffic signs placed.
76. **TECHNICAL REVIEW COMMITTEE (TRC):** A formal group of representatives from public and private utility companies in the Santa Clara area that meet as needed to review and approve utility plans as required.
77. **UNDERGROUND FACILITIES:** All pipelines, conduits, ducts, cables, wires, manholes, vaults, tanks, tunnels, or other such facilities or attachments. Any encasement containing facilities which have been installed underground to furnish any of the following services or materials: electricity, gases, steam, liquid petroleum products, telephone or other communication, cable television, sewage and drainage removal, traffic, or other control systems.
78. **WATER DEPARTMENT:** Shall refer to the City of Santa Clara Water Department and its authorized city representative.
79. **WORK:** The construction services and materials required to furnish in accordance with the approved documents. Work is the result of performing services, furnishing labor, and furnishing and incorporating materials and equipment into the construction.
80. **WORK COMPLETION/COMPLETION OF WORK:** Work and all obligations which have been fulfilled in accordance with the approved documents.
81. **XERISCAPE:** Desert-type landscaping requiring low-water demand as approved by the city.



**1.3 BONDS AND INSURANCE.** The Contractor shall be required to obtain all necessary bonds and to carry and provide proof of all necessary insurances needed to carry out the work.

**1.4 STARTING AND COMPLETING THE WORK.** The Contractor shall start the work in a timely manner after receiving the approved plans. Work shall be performed in an expeditious manner so as not to unduly inconvenience the public. Work should be continuous without long periods of stoppage. Twelve (12) months from permit to final inspection is suggested. An extension may be granted by the city representative if necessary.

**1.5 BEFORE CONSTRUCTION BEGINS.** Before undertaking each part of the work, the Contractor shall carefully study and compare the approved plans and check and verify pertinent figures shown thereon and all applicable field measurements. The Contractor shall promptly report to the Owner and the city's representative any conflict, error, or discrepancy which Contractor may discover and shall obtain a written interpretation or clarification from the Owner's Engineer and the city's representative before proceeding with any work affected thereby.

Before any work at the site is started, Contractor shall deliver to city's representative copies of all permits which Contractor is required to purchase/obtain and maintain, and Contractor's written plan to control quality of products and workmanship in the work.

**1.6 PRECONSTRUCTION CONFERENCE.** Before Contractor starts the work at the site, Contractor will attend a conference with Owner, Owners Engineer, and city's representative, for the following purposes:

1. To discuss the work and the proposed schedule,
2. To discuss procedures for processing the project,
3. To designate the name of the individual who shall have the authority to always act for The Contractor while work is in progress, and
4. To establish a working understanding among the parties as to the work. A document stating understanding of expectations and standards must be signed by the contractor at the preconstruction conference meeting.

**1.7 APPROVED DOCUMENTS INTENT.** It is the intent of the approved plans and the standard specifications to describe a functionally complete project to be constructed in accordance with City Standards and good engineering practices. Any work, materials, or equipment that may reasonably be inferred from as being required to produce the intended result will be supplied whether specifically called for. When words which have a well-known technical or trade meaning are used to describe work, materials or equipment, such words shall be interpreted in accordance with that meaning. Reference to standard specifications, manuals, or codes of any technical society, organization, or association, or to the laws or regulations of any governmental authority, whether such reference be specific or by implication, shall mean the latest standard specification, manual, code or laws or regulations in effect at the time of approval of the project, except as may be otherwise specifically stated.

If, during the performance of the work, Contractor finds a conflict, error or discrepancy in the approved plans or these standards, Contractor shall so report to the Owner and the city's representative at once and before proceeding with the work affected thereby shall obtain an interpretation or clarification from Owner's Engineer and city's representative:

1. In the event of any discrepancy between the scaled dimensions on any drawing and the written dimensions shown thereon, the written dimensions shall be taken as correct.

2. Any part of the work, which is not mentioned in the specifications, but is shown on the drawings, shall be furnished, and installed by Contractor as if fully described in the specifications.

3. Work and materials shall conform to the lines, grades, dimensions, and material requirements, including tolerances, shown in the Standard Specifications and on the Approved Drawings. Although measurements, sampling and testing may be considered evidence as to such conformity, city's representative shall be the sole judge of whether the work or materials deviate from the approved documents and City representative's decision as to any allowable deviations therefrom shall be final. Deviation from approved documents, as may be required by the needs of construction, will be determined in all cases by the city representative or designee.

4. Performance by the Contractor shall be required only to the extent consistent with the approved documents and reasonably interpreted from the approved plans and standard specifications and any approved supplementary specifications as being necessary to produce the intended results. In case of an irreconcilable conflict between provisions the city representative's decision shall be final.

**1.8 AMENDING AND SUPPLEMENTING THE APPROVED DRAWINGS.** The approved drawings may be amended on or after the effective date to provide for additions, deletions, and revisions in the work thereof. All amendments, supplements, changes, and directives

require approval of the city representative or designee.

**1.9 UNDERGROUND FACILITIES SHOWN OR INDICATED.** The information and data shown or indicated in the approved plans with respect to existing underground facilities, or contiguous to the site, are generally based on information and data furnished by others, unless it is otherwise agreed to:

1. The City shall not be responsible for the accuracy or completeness of any such information or data;
2. Contractor and Owner shall have full responsibility for reviewing and checking all such information and data, with the one-call center (Blue Stakes location center) or other utility coordination service, prior to any excavation, to locate all underground facilities shown or indicated in the approved plans, for coordination of the work with the owners of such underground facilities during construction, and for the safety and protection thereof and repairing any damage thereto resulting from the work.

**1.10 UNDERGROUND FACILITIES NOT SHOWN OR INDICATED.** If an underground facility is uncovered or revealed at or contiguous to the site which was not shown or indicated in the plans the Contractor shall promptly, and before performing any work affected thereby (except in an emergency), identify the owner of such underground facility, and give appropriate notice thereof to that owner and to city's representative. The Owner's Engineer will promptly review the underground facility to determine the extent to which the plans should be modified to reflect and document the consequences of the existence of the underground facility. The plans will be amended or supplemented to the extent necessary. During such time, Contractor shall be responsible for the safety and protection of such underground facility.

**1.11 REFERENCE POINTS AND MONUMENTS.** Owner's Representative shall establish land survey reference points for construction to enable Contractor to proceed with the work. The contractor shall be responsible for laying out the work, shall protect and preserve the established reference points and shall make no changes or relocations without the prior approval of city's representative. The contractor shall report to the City's and Owner's Representative whenever any reference point is lost or destroyed or requires relocation because of necessary changes in grades or locations and shall be responsible for the accurate replacement or relocation of such reference points by professionally qualified personnel.

The contractor shall not disturb any survey monuments found within the construction area until approved by the city's representative. No survey monument shall be disturbed or moved until city's representative has been notified and Owner's Representative has referenced the survey monument for resetting.

**1.12 CONTRACTOR'S RESPONSIBILITIES - SUPERVISION AND SUPERINTENDENCY.** The contractor shall supervise and direct the work competently and efficiently, devoting such attention thereto and applying such skills and expertise as necessary to perform and complete the work in accordance with the approved plans and the standard specifications. The contractor shall be solely responsible for the means, methods, techniques, sequences

and procedures of construction. The contractor shall be responsible for seeing that the finished work complies accurately with the approved documents.

The contractor shall always keep on the site during the works progress a competent superintendent. The superintendent will be Contractor's representative at the site and shall have authority to act on behalf of Contractor. All communications given to the superintendent shall be as binding as if given to Contractor.

**1.13 SAFETY AND PROTECTION.** The contractor shall be responsible for initiating, maintaining, and supervising all safety precautions and programs in connection with the work. The contractor shall take all necessary precautions for the safety of, and shall provide the necessary protection to prevent damage, injury, or loss to:

1. All employees on the work and other persons and organizations who may be affected thereby;
2. All the work and materials and equipment to be incorporated therein, whether in storage on or off the site; and
3. Other property at the site or adjacent thereto, including trees, shrubs, lawns, walks, pavements, roadways, structures, utilities, and underground facilities not designated for removal, relocation, or replacement during construction.

The contractor shall comply with all applicable laws and regulation of any public body having jurisdiction for the safety of persons or property, or to protect them from damage, injury, or loss. The Contractor shall erect and maintain all necessary safeguards for such safety and protection. The contractor shall notify owners of adjacent property and of underground facilities and utility owners when prosecution of the work may affect them, and shall cooperate with them in the protection, removal, relocation, and replacement of their property. All damage, injury or loss to any property caused, directly or indirectly, in whole or in part, by the Contractor, any subcontractor, supplier or any other person or organization directly or indirectly employed by any of them to perform or furnish any of the work or anyone for whose acts any of them may be liable, shall be remedied by Contractor. Contractors' duties and responsibilities for the safety and protection of the work shall continue until such time as all the work is completed, and city's representative has issued a notice to Contractor that the work is acceptable.

The City, its officers, employees and agents, and the city's representative shall not be answerable or accountable in any manner for any damage or loss that may happen to the work or any part thereof; for any material or equipment used in performing the work; for injury to property or person or persons; for damage to property; or for damage to adjoining property from any cause whatsoever during the progress of the work or at any time before final acceptance.

The contractor shall have the charge and care of the work and shall bear the risk of injury or damage to any part thereof by any acts of God or the elements or from any other cause. The contractor shall rebuild, repair, and restore, and make good all injuries or damages to any portion of the work occasioned by any of the above causes before the date of final acceptance and shall bear the expense thereof.

The city may make, or cause, to be made such temporary repairs as is necessary to restore service to any damaged facility. The cost of such repairs shall be borne by the **Contractor**.

The Contractor acknowledges that he is familiar with and will conform with the latest general safety orders of the State Industrial Commission, as contained in the Utah Occupational Safety and Health Act. The presence on site of an inspector or other person representing the City shall not in any way be construed to limit the Contractor's full responsibility for safety of all persons on the premises.

**1.14 SITE EMERGENCIES.** In emergencies affecting the safety or protection of persons or the work or property at the site or adjacent thereto, Contractor, without special instruction or authorization from city's representative is obligated to act to prevent threatened damage, injury, or loss. The contractor shall give city's representative prompt written notice if Contractor believes that any significant changes in the work or variations from the approved documents have been caused thereby.

**1.15 AUTHORIZED VARIATIONS IN WORK.** Variations in the work shall be authorized by the Owner's Engineer and approved by the city's representative.

**1.16 REJECTING DEFECTIVE WORK.** The city's representative and the Owner and his Engineer will have authority to disapprove or reject work which they believe to be defective and will also have authority to require special inspection or testing of the work whether the work is fabricated, installed or completed.

**1.17 WARRANTY AND GUARANTEE.** Contractor warrants and guarantees to City that all work will be in accordance with the approved documents and will not be defective. All defective work, whether in place, may be rejected, corrected, or accepted with conditions at the sole discretion of the City. If within the one year guarantee period, or such longer period of time as may be prescribed by laws or regulations, or by the terms of any applicable special guarantee required, or by any specific provision of the approved documents, any work is found to be, defective regardless of cause, the Owner shall promptly cause the Contractor, without cost to the City, either correct such defective work, or, if it has been rejected by the City, remove it from the site and replace it with non-defective work. If the workmanship or materials are found to be questionable with agreeance of both parties, the warranty may be extended.

**1.18. INSPECTIONS AND OBSERVATIONS.** The contractor shall give city's representative at least twenty-four hours' notice of readiness of the work for all required inspections, or approvals. Inspections and tests made at any point other than the point of incorporation in the work shall not be considered as a guarantee of acceptance. Any retesting of work or materials rejected shall be at Contractor's expense. Any reinspection that is caused by the Contractor not being ready may be charged a fee for each reinspection.

The city's representative(s), Owner's Engineer, testing agencies and governmental agencies with jurisdictional interests will have access to the work at reasonable times for their observation, inspecting and testing. The contractor shall provide proper and safe

conditions for such access.

If laws or regulations of any public body having jurisdiction require any work (or part thereof) to specifically be inspected, tested, or approved by other than city's representative and the Owner's Engineer, Contractor shall assume full responsibility therefor, and furnish the city's representative the required certificates of inspection, testing, or approval.

The contractor shall be responsible for all costs in connection with any inspection or required testing in connection with City's acceptance of materials supplied, or equipment proposed to be incorporated in the work, or of materials or equipment submitted for approval prior to Contractor's purchase thereof for incorporation in the work.

All work and materials, and the manufacture and preparation of such materials from the beginning of the work until work completion, shall be subject to acceptance or rejection by the city's representative.

Any work or materials not in accordance with the approved documents that may be discovered before work completion shall be corrected upon notification by city's representative. Inspection by city's representative shall not relieve Contractor from responsibility to furnish material and workmanship in accordance with the approved documents. Failure on the part of city's representative to discover, condemn or reject materials or work shall not be construed to imply acceptance of the same should their noncompliance become evident before work completion. It is expressly understood that nothing in this paragraph waives any of the City's rights under the guarantee provision of these specifications.

**1.19 CONTRACTOR EMPLOYEES.** Only competent employees of the Contractor, or subcontractor, shall be employed on the work project. Any person employed by Contractor, the sub-contractor themselves, or subcontractor employees, who is found by city's representative to be incompetent, intemperate, troublesome, disorderly, or otherwise objectionable, or who fails or refuses to perform work properly and acceptably, shall be immediately removed from the work project by the Contractor and not be re-employed on the work project.

**1.20 HISTORIC, ARCHAEOLOGICAL OR PALEONTOLOGICAL DISCOVERIES.** If a suspected regulatory historic, archeological, or Paleontological item, feature, or site is encountered, construction operations shall be immediately stopped in the vicinity of the discovery and the Owner and proper state and/or federal agencies shall be notified of the nature and exact location of the findings. The Contractor shall not damage the discovered objects. The Owner shall keep the city's representative informed as to the status of any restrictions placed upon the project and when such restrictions are removed

**1.21 WORKING HOURS.** Construction activities on the contract work site shall comply with any applicable local noise and other ordinances. Unless otherwise directed or upon approval of different hours by city's representative, working hours at the work site shall be limited between 6:00 A.M. and 7:00 P.M. local time. Work outside of these hours requires a noise exemption permit from the city's representative. Work shall not proceed on Saturday, Sunday, or on any legal holidays without prior approval from the city's representative.

**1.22 UNCOVERING WORK.** If any work is covered or buried contrary to the request of city's representative, it must, if requested, be uncovered for observation, inspection or testing as may be required to verify compliance at the Contractor's expense.

**1.23 CITY'S REPRESENTATIVE MAY STOP THE WORK.** If the work is defective, or the Contractor fails to supply sufficient skilled workers or suitable materials or equipment or fails to furnish or perform the work in such a way that the completed work will not conform to the approved documents, city's representative may order Contractor to stop the work, or any portion thereof, until the cause for such an order has been eliminated.

**1.24 CORRECTION OR REMOVAL OF DEFECTIVE WORK BY CONTRACTOR.** If required by the City's Representative, the Contractor shall promptly, as directed, correct all defective work, whether fabricated, installed or completed, or if the work has been rejected by the city's representative, remove it from the site and replace it with non-defective work. The Contractor shall bear all direct, indirect, and consequential costs of such correction or removal (including but not limited to fees and charges of the City, engineers, architects, attorneys, and other professionals) made necessary thereby.

**1.25 ONE YEAR CORRECTION PERIOD.** If within the one year guarantee period, or such longer period of time as may be prescribed by laws or regulations, or by the terms of any applicable special guarantee required, or by any specific provision of the approved documents, any work is found to be defective regardless of cause, the Owner shall promptly cause the Contractor, without cost to the City, either correct such defective work, or, if it has been rejected by the City, remove it from the site and replace it with non-defective work. If the Contractor fails within thirty days to promptly comply with the terms of such instructions, or in an emergency where notice and delay would cause serious risk of loss or damage, the City may have the defective work corrected or the rejected work removed and replaced, and the Owner shall be liable for all direct, indirect, and consequential costs of such removal and replacement. The one-year correction period shall similarly apply to all rework done by the Contractor.

**1.26 ACCEPTANCE OF DEFECTIVE WORK.** If, instead of requiring correction or removal and replacement of defective work, and City prefers to accept it, City may do so. Owner shall bear all direct, indirect, and consequential costs attributable to city's representative evaluation of and determination to accept such defective work.

**1.27 CORRECTION OR REMOVAL OF DEFECTIVE WORK BY OWNER.** If Owner fails within a reasonable time after written notice of city's representative to correct defective work or to remove and replace rejected work, as required by city's representative, or if Contractor fails to perform the work in accordance with the approved documents, City may, after seven days' written notice to Owner, correct and remedy any such deficiency. All

direct, indirect, and consequential costs of City in exercising such rights and remedies will be charged to the Owner. Such direct, indirect, and consequential costs will include but not be limited to fees and charges of engineers, architects, attorneys and other professionals, all court costs and all costs of repair and replacement of work of others destroyed or damaged by correction, removal, or replacement of defective work.

**1.28 WORK FULLY COMPLETED.** When Owner considers the work (or portion thereof) ready for its intended use, Contractor shall certify in writing to city's representative that the work (or portion thereof) has been completed in accordance with the approved documents. If fully completed, city's representative shall within a reasonable time, schedule a **final inspection** preparatory to writing the final inspection punch list and in accordance with these standard specifications and City policies.

**1.29 FINAL INSPECTION.** After all construction work is complete, the Developer shall request a Construction Completion Inspection@ (final inspection). Upon receipt of the request the City shall schedule this inspection with the appropriate parties. Any faulty or defective work shall be detailed in the City's inspection report. All faulty and defective work shall be corrected within 30 days from the date of the City's inspection report. If, after thirty days, the faulty or defective work has not been completed, another final inspection may be conducted by the city to determine if additional corrective work is required. The development will not be released, and the guarantee period will not commence until all faulty work has been corrected.

**1.30 FINAL WALKTHROUGH.** Prior to the end of the guarantee period, a final walk through will be conducted. The Owner and the Contractor should contact the city's representative to schedule the walk through. All work found to be defective shall be corrected immediately. This is preparatory to final acceptance by the city.

**1.31 FINAL INSPECTION.** When Owner considers the work (or portion thereof) ready for its intended use, Contractor shall certify in writing to city's representative that the work (or portion thereof) has been completed in accordance with the approved documents. If fully completed, city's representative shall within a reasonable time, schedule a final inspection preparatory to writing the final inspection punch list and in accordance with these standard specifications and City policies.

**1.32 FINAL ACCEPTANCE.** If, based on Owner's and Contractor's request that work is given final acceptance and city's representative is satisfied that the work has been satisfactorily completed the city's representative will give written notice to Owner that the work is acceptable, and the guarantee period will start. Otherwise, city's representative will indicate in writing to Owner the reasons for refusing to recommend final acceptance, in which case Owner shall make the necessary corrections and resubmit request for final acceptance approval.

**1.33 SUSPENSION OF WORK.** The city's representative shall have the authority to suspend the work wholly or in part for such period as city's representative may deem necessary due to unsuitable weather or to other conditions the city's representative considers unfavorable for suitable prosecution of the work. The Contractor shall immediately comply with the city's representative order to suspend the work wholly or in part. The suspended work shall be resumed when the conditions are favorable, and methods are



corrected as approved by the city's representative. In the event the suspension of work is ordered for any reason, the Contractor, at Contractor's expense shall do the work necessary to provide a safe and secure site. If pedestrian or vehicular access is required, a smooth and unobstructed passageway shall be provided through the construction site for use by the public. In the event the Contractor fails to perform this work, the City may perform such work and the cost thereof will be billed to the Contractor or Owner.

## SECTION 2

### GENERAL REQUIREMENTS

**2.1 INTRODUCTION.** This section defines the general requirements for public improvements within Santa Clara City.

The improvements shall include all public and private infrastructure, including, but not limited to streets, water, sewer, traffic, and drainage. Required improvements shall extend from the nearest acceptable point of existing improvements. Layouts must provide for future extension to adjacent properties and shall be compatible with appropriate City of Santa Clara Master Plans or General Plan elements. All underground improvements shall be installed to the boundary lines of the development and in some cases extended beyond the boundary to assure system reliability. Required Geotechnical investigation recommendations shall be followed.

**2.2 CONSTRUCTION DRAWINGS.** Complete and detailed construction plans, drawings of improvements, and all necessary reports shall be submitted to the City for review and acceptance. All plans, drawings and reports submitted shall be stamped and signed by a professional Civil Engineer licensed in the State of Utah.

The instructions contained herein are for the purpose of standardizing the preparation of drawings and to obtain uniformity in appearance, clarity, size, and style. The plans and drawings shall meet the standards hereinafter outlined.

All drawings and/or prints shall be clear and legible and conform to standard engineering and professional drafting practice.

The standard drawing size shall be twenty-four by thirty-six inches.

Note: Construction work shall not begin until the appropriate construction plans, and reports have been reviewed for compliance with City requirements and released for construction by the city representative.

**2.2.1 GENERAL.** The following shall be included on the drawings. The city may require additional information as it deems necessary:

A. North arrow.

B. Scale - Standard engineering scales shall be used. Uncommon scales generated by CAD systems shall not be used. Graphic scales should be used where drawings may be reduced.

C. Stationing and elevations for profiles - Profiles should be drawn directly below plan view when possible. Benchmarks and elevations must be referenced to the latest revision of the USGS datum as may be approved.

D. Title block, located on the right side of the sheet to include:

1. Project title.
2. Type of project.
3. Professional Engineers stamp (licensed in the State of Utah) and signature.
4. Name, address, and phone number of firm preparing drawings.
5. Date, drawing number, drawn by, checked by, and other appropriate information.
6. Name, address, and telephone number of Owner/Developer and contact person.

E. Revision block, located in or above title block containing the revision number, description, date, and revisor's name.

F. Drawings shall have a heavy border outlining the entire sheet situated approximately two inches from the top and sides and 1 inch from the bottom.

G. Additional information as required by the Technical Review Committee (TRC) shall also be required on the drawings. (See the TRC for requirements).

H. Finished pad elevations for each building lot.

I. A coversheet to include total acreage of project, lot count, open space, and common space acreage.

J. Include a copy of the preliminary plat and electronic copy in auto-cad.

**2.2.2 CURB AND GUTTER, DRAINAGE, SIDEWALKS AND STREETS.** The drawings for curb and gutter, drainage, sidewalks, and streets must include two (2) sets of 24' x 36" drawings as well as one (1) copy of the preliminary plat for review and redlines and shall contain:

A. Plan view showing all necessary information to completely detail the work to be constructed including, but not limited to, all existing improvements, right-of-way lines, easement boundaries, roadway centerline, curb and gutter location, sidewalks, cross drains, cut and fill slopes, drainage pipes, etc. for each street.

- B. Top back of curb, and street centerline elevations at one hundred (100) foot intervals or at every lot line and at all P.C.s, midpoints, and P.T.'s. At all street intersections, elevations shall be shown at the half delta points (minimum).
- C. Standard engineering stationing and all curve data.
- D. Plan, profile, and details of drainage system showing flow directions, pipe grades, inlets, clean outs, invert elevations, and type of pipes, etc.
- E. Benchmark locations and elevations (latest revisions of USGS datum must be used).
- F. Typical street cross section from right-of-way line to right-of-way line, showing type of curb, sidewalk, and pavement section.
- G. Gradient center line of roads, top, back of curbs (if different from the centerline), or edge of the pavement (if different from centerline and no curb exists), and flowlines of drainage pipes and channels. Profiles shall be shown at all intersections to assure that street grades transition smoothly. Transition grades shall not be left to be worked out in the field!
- H. Location of existing and proposed permanent survey monuments.
- I. Profiles shall show existing ground profile at the centerline and each right of way line.
- J. When matching into existing improvements, profiles shall be extended for a minimum of two hundred and fifty (250) feet to assure that road transitions are smooth. When matching into existing improvements from the opposite of the street, cross-sections shall be shown indicating how the new portion will match.

K. Plan, profile, and details of drainage system showing flow directions, pipe grades, inlets, clean outs, invert elevations, and type of pipes, etc.

L. Benchmark locations and elevations (latest revisions of USGS datum must be used).

M. Typical street cross section from right-of-way line to right-of-way line, showing type of curb, sidewalk, and pavement section.

N. Gradient center line of roads, top, back of curbs (if different from the centerline), or edge of the pavement (if different from centerline and no curb exists), and flowlines of drainage pipes and channels. Profiles shall be shown at all intersections to assure that street grades transition smoothly. Transition grades shall not be left to be worked out in the field!

O. Location of existing and proposed permanent survey monuments.

P. Profiles shall show existing ground profile at the centerline and each right of way line.

Q. When matching into existing improvements, profiles shall be extended for a minimum of two hundred and fifty (250) feet to assure that road transitions are smooth. When matching into existing improvements from the opposite of the street, cross-sections shall be shown indicating how the new portion will match.

### **2.2.3 SEWER/STORM DRAIN.** Sewer/Storm Drain drawings shall show:

A. Plan and profile sheets showing location, size, and grade of main lines, submains, and service laterals (existing and proposed).

B. Manhole size, type, station (location) and elevation at top of manhole and flowline (in and out).

C. Type of pipe (in accordance with City's standards).

D. Benchmark locations and elevations (latest revision of U.S.G.S. datum shall be used).

E. Trench details showing bedding backfill, compaction and shoring requirements.

F. One Hundred Year Floodplain Information.

### **2.2.4 CULINARY WATER.** Culinary water drawings shall show:

A. Size, location and type of all existing and proposed water mains, valves and hydrants, service laterals and all necessary appurtenances.

- B. Type of pipe (in accordance with city standards).
- C. Profile drawings showing high and low elevation with respect to grade.
- D. Minimum cover shown (thirty-six inches to top of pipe).
- E. Typical and special trench details showing bedding, backfill, compaction and shoring requirements.
- F. Backflow protections devices.

**2.2.5 SECONDARY WATER.** The following will be required for the installation of the secondary water systems:

- A. ¾" service with a ¾" meter setter will be installed to each lot.
- B. All piping including service laterals must be purple in color and clearly marked irrigation.
- C. The meter setter must be installed within a purple meter box clearly marked "Irrigation".
- D. All piping to be installed must have a five-foot minimum separation from culinary piping.
- E. All main line valve boxes must be triangular in shape.
- F. The requirements of section 3 and 4 for culinary water will apply for the installing of all material.

**2.2.6 POWER.** Power drawings shall show:

- A. Point of interconnect (to be determined by city's representative before plans are prepared and submitted).
- B. Location of existing and proposed transformers, service boxes, streetlights, etc.
- C. Primary, secondary, and service lines, and phasing details.
- D. Topography and proposed grading unless shown on grading plans.
- E. Sizes, capacities, and characteristics of all components (e.g., wire, transformers, etc.).
- F. Approval block for respective utility.

**2.2.7 DETAIL SHEETS.** Each set of plans shall be accompanied by a separate sheet of details (unless already shown on standard drawings) for structures which will be constructed. Detail sheets shall include the following information:

- A. Drawing size: twenty-four (24") by thirty-six inches (36").
- B. Scale of each detail.
- C. Title block on the right side of the sheet (same format on all sheets).
- D. Information required in Section 2.2.1., Items A thru J.
- E. All details must be dimensioned and labeled.

F. All details shall conform to the details shown in the standard drawing section of these standards. All details not in conformance with the standard details shall require individual approval.

**2.2.8 GRADING PLAN.** All development projects and projects requiring installation of public and private improvements, are required to obtain a grading permit. A grading plan shall be submitted. The grading plan must be included with the Construction Drawings when submitted to the city for review.

A Geotechnical Investigation Report and an Engineering Geology Report addressing the adequacy for the intended use of the proposed development shall be submitted with the grading plan. If the geotechnical investigation was completed more than 3 years (1095 days) prior to the submittal date, then it's no longer valid without a current updated letter/report indicating that the original investigation remains valid. A Geological Hazard Assessment may also be required by the city representative.

### **2.2.9 GENERAL UTILITY LOCATION INFORMATION.**

The following information is provided as a general guide in laying out utilities during the preparation of construction drawings. This information is to be used as a guide and may be changed by the city as required.

- A. A proximity detail and street locations will be required for all utility drawings.
- B. The sewer, drainage and power layouts should be the first utilities designed.
- C. For joint trench details, placement and layout of utilities and burial depths, see standard drawings.
- D. A joint trench for phone, fiber, internet, cable, and power shall be located on the north and west side of the roadway behind the sidewalk (whenever possible) or opposite gas. In planned developments without sidewalks, joint utility trenches shall be thirty-six inches from the back of the curb.
- E. Water and gas lines shall be located on the south and east side of the roadway with the gas line located behind sidewalk and water line located five feet into the roadway measured from the lip of the curb (whenever possible) or opposite power. In planned developments, gas shall be located behind sidewalk. The water location would remain the same.
- F. Sewer lines will generally be located fifteen (15) feet from the curb and gutter on the same side of the road as the power system.
- G. Storm drain lines will be placed at the inside lip of curb and gutter as per standard drawing detail.
- H. Refer to Section 2.2.5 above. A minimum two-foot separation is required from culinary to secondary.
- I. The cable and phone boxes will be located on the right and left side of power transformers and secondary boxes. The cable shall be on the left and phone on the right when looking from the street at the lot to be served.
- J. Gas mains shall be located five feet minimum off the back of the sidewalk on public streets.
- K. Gas alongside stubs will be placed five feet to the right or left of the property line.



L. Water services shall be placed a maximum of 5 feet from property line to not interfere with planned drive approaches or driveways.

M. Color coding for utility conduits/lines shall be as follows:

- Power - Black with red stripe or gray
- Water - Blue or white or ductile iron
- Sewer - Green or white
- Gas - Orange or yellow
- Phone - White or gray and labeled
- Secondary Water- Purple
- Cable TV  
- Dark green 2" stripe with company label

**2.2.9 DRAWING SUBMITTALS.** Three (3) sets of construction plans and drawings shall be submitted to the city representative for review. Additional sets of drawings in accordance with TRC requirements shall also be submitted to the TRC for review. When all revisions required by the City have been made and the plans accepted, five (5) complete sets shall be submitted to the city representative for processing. Two sets of plans that have been appropriately stamped as released for construction will be returned to the applicant. One stamped set shall be always kept available at the construction site during the construction of the project.

**2.3 INSPECTION, TESTING AND QUALITY CONTROL.** All construction work involving the installation of improvements in Santa Clara City shall be subject to inspection and testing as outlined in the quality control section of each specification. Certification from the developer's professional engineer may be required for all or part of the project at completion of the project.

**2.3.1 REQUESTS FOR INSPECTION.** A request for inspection shall be made to the City by the person responsible for the construction. Notice shall be given at least twenty-four hours (or as otherwise directed) in advance of the starting of work. Any work requiring backfill or cover shall not be backfilled or covered prior to inspection. It should be noted that any inspection or observation by the city is for the City's sole use and does not relieve the Contractor or Developer from complying with City

standards. The city provides inspections throughout the course of work. These inspections should not be confused with that of providing full time observation or inspection. It is recommended that the Developer retain the use of a professional engineering firm during construction to provide the necessary periodic special inspections to ensure that said standards are met and to certify as such. Said certification is required for private developments.

**2.3.2 CONSTRUCTION COMPLETION INSPECTION (FINAL INSPECTION).** After all construction work is complete, the Developer shall request a Construction Completion Inspection. Upon receipt of the request the City shall schedule this inspection with the appropriate parties. Any faulty or defective work shall be detailed in the City's inspection report. All faulty and defective work shall be corrected within 30 days from the date of the City's inspection report. If, after thirty days, the faulty or defective work has not been completed, another final inspection may be conducted by the city to determine if additional corrective work is required. The development will not be released, and the guarantee period will not commence until all faulty work has been corrected.

**2.3.3. GUARANTEE/WARRANTY.** All work shall be warranted and guaranteed to remain in good condition for a period of one year after the date indicated in Section 2.3.2 or other date as determined by the city representative. The responsible party shall agree to make all repairs to and maintain the improvements and every part thereof in good condition during the specified time at no cost to the City. A 10% improvement guarantee provided by the Developer of improvements will be required by the city for the period of the one-year guarantee.

The determination for the necessity of repairs and maintenance of the work shall rest with the City representative. His decision upon the matter shall be final and binding. The guarantee hereby stipulated shall extend to and include but shall not be limited to the entire road base, power system, all pipes, joints, valves, backfill and compaction as well as the working surface, curbs, gutters, sidewalks, and other accessories that shall be constructed. Whenever, in the judgment of the city representative, said work shall need repairs, maintenance, or rebuilding, he shall cause a written or other notice to be served the responsible party and thereupon the responsible party shall undertake and complete such repairs, maintenance, or rebuilding. If the responsible party fails to do so within thirty days from the date of the service of such notice, the city representative may have such repairs made, and the cost of such repairs shall be paid by the responsible party together with 25 percent of the cost of the repairs in addition thereto, for stipulated damages for such failure on the part of the responsible party to make the repairs. Any omission on the part of the city representative, or his designated representative, to condemn defective work or material at the time of construction shall not be deemed an acceptance. The Contractor will be required to correct defective work or material at any time within the one-year before final acceptance.

Prior to the end of the one-year guarantee period, a final walk through for final

acceptance will be conducted. All work found to be defective shall be repaired immediately. Upon completion of these final repairs, the work will be accepted by the City and all appropriate bonds released.

**2.3.4 QUALITY CONTROL TESTING.** Material testing shall be conducted by an independent AASHTO accredited testing laboratory. The testing laboratory used for this purpose shall be one that is approved by the City. All testing shall comply with current ASTM, AASHTO, AWWA, Public Drinking Water Regulation standards, or other applicable standards and these specifications. All testing shall meet the minimum testing requirements as outlined in the specifications. The cost of all re-testing required to bring materials into compliance shall not be borne by the City. If determined necessary by the city, additional testing may be required. All testing shall be performed by the appropriately certified tester.

**2.3.5 TEST REPORTS.** Written test results are required for each portion of the work completed (i.e., pipeline construction, earthwork, curb, gutter, sidewalk, and roadway construction) in accordance with minimum testing frequencies specified herein and should be available for City review upon request.

An interim compliance report shall be submitted prior to any paving or concrete placement operations. The interim report shall include: (a) compaction test results for all underground and subgrade work; (b) compaction and gradation test results for road base materials.

A final report of compliance will be required upon completion of the project. This report will include all test results, and any other items required in the plans and specifications.

A letter of compliance with minimum inspection and testing requirements as set forth herein, must be submitted for any private subdivision, planned unit development and/or other developments which contain private streets. This letter must be on a form approved by the city and stamped and signed by a Professional Engineer licensed in the State of Utah.

**2.4 DRAWINGS OF RECORD.** Upon completion of the project and prior to final inspection, a complete set of Drawings of Record that includes all items specified in SECTION 2.2 Construction Drawings shall be submitted to the City. The Drawings of Record shall show all improvement dimensions as they were constructed in the field. The Drawings of Record shall be submitted on twenty-four inches by thirty-six inches sheets and in electronic format in AutoCAD version 2000 drawing format in accordance with City policy (unless otherwise directed by the city's representative). Improvements and any bond held by the City shall not be released until drawings of record are received.

The Developer's project engineer shall be required to submit drawings of record containing the signatures of the contractor and the developer's engineer. They shall include a transmittal letter, in duplicate, containing the submittal date, project title, and signature of the Contractor, or Contractor's authorized representative indicating concurrence by the Contractor. The Developer's Project Engineer shall be responsible for the accuracy of the

record drawings and shall be stamped and signed by the Professional Engineer, that each drawing of record is complete and accurate.

The submitter shall also provide all drawings of record in AutoCAD format latest update, on a CD dwg file format, digital PDF, or as otherwise directed by the City's Representative upon completion of the project.

**2.5 BARRICADES AND WARNING SIGNS - WORK AREA PROTECTION.** The Contractor shall provide, erect, and maintain all necessary barricades, channelizing devices, lights, warning signs, and other traffic control devices. All necessary precautions shall be taken to protect the work area and to safeguard the public and construction workers. Streets closed to traffic shall be protected by proper barricades, and obstructions shall be illuminated during hours of darkness. Suitable warning and detour signs shall be provided to control and direct traffic properly. All traffic control operations and signing shall be performed in accordance with the instructions outlined in the "Manual on Uniform Traffic Control Devices (MUTCD)", latest edition. A traffic control plan shall be required on each project.

### **2.5.1 GENERAL MAINTENANCE OF TRAFFIC (MOT) REQUIREMENTS**

The Contractor shall always so conduct his work as to assure the least possible obstruction to traffic and adjacent residents. The safety, convenience, and the protection of persons, property, general public, and residents along the street, highway, and areas adjacent to the work area shall be provided for by the Contractor.

Temporary traffic control devices shall be used to guide and channel traffic through construction areas. Devices shall include cones, portable barricades, vertical panels, and other approved devices. Metal vertical panels shall not be used as channelization devices. Traffic cones shall not be permitted as traffic channelizing devices during the hours of darkness.

Warning devices shall be used to alert the motorist of an obstruction in the roadway. They include diamond-shaped signs, flags, and flasher type high level warning devices.

All temporary traffic control devices used during hours of darkness shall be properly reflectorized and lighted, in accordance with requirements of the MUTCD. Devices shall have adequate maintenance to retain the reflection and lighting capability. At all times, traffic control devices shall be erect, properly positioned, clean, and in full view of the intended traffic movement.

All traffic control devices shall be immediately removed from roadway or sidewalk when no longer needed.

A traffic lane should be a minimum of ten feet wide. Additional width may be necessary depending on the conditions encountered.

A minimum of two traffic lanes, one for each direction, shall be always maintained open to traffic on all major streets unless otherwise approved by the city representative.

When two-way traffic cannot be maintained, a flagging operation shall be provided.

Persons must be certified and suitably equipped and properly clothed.

Unless otherwise approved by the city's representative, all existing traffic lanes on major streets shall be maintained open to traffic during peak hours, generally from 7:30 AM to 8:30 AM and 4:30 PM to 5:30 PM weekdays.

Local access shall be always maintained to all properties on the project. When local access cannot be maintained, the Contractor must notify the affected property owner at least twenty-four hours in advance. Access shall be restored the same day of completion of work which caused loss of access.

A temporary traffic lane shall not be open to traffic unless it is paved with hot mix or cold mix asphalt or is graded reasonably smooth and maintained dust free as directed by the City's Representative.

Arrangements for partial or complete street closure permits shall be obtained through the city representative or designee. An advance notice of forty-eight hours for major streets and twenty-four hours for local streets and alleys is required. The Contractor shall be required to notify all emergency services (ambulance, fire, etc.) and all other necessary parties as dictated by the city's representative.

The Contractor is responsible for all barricading, 24-hours a day, 7-days a week. In the event of inclement weather conditions, such as windstorms, rainstorms, etc. the Contractor (or authorized representative) shall immediately inspect his work area and take all necessary actions to ensure that public access and safety are maintained. In general trenches and excavations shall not be left open or uncovered overnight. Special conditions may be given consideration by the city's representative.

The Contractor shall maintain all existing STOP, YIELD, street name signs and other traffic control devices until such time as construction requires their removal. At that time the Contractor shall obtain authorization from the City to remove said signs and posts without damage and deliver them to a storage site as directed by the city representative. When required, the Contractor may need to install temporary signs (i.e., regulatory signs) until such time as permanent signs can be reinstalled. The city will reinstall all traffic signs.

If at any time project construction shall require the closure or disruption of traffic in any roadway or alley such that normal refuse collection will be interfered with, the Contractor shall, prior to causing such closure or disruption, make arrangements with the appropriate refuse removal service in order that collection service can be maintained.

The Contractor shall provide the city's representative with a 24-hour emergency phone number of his representative(s) responsible for maintenance of barricades, warning signs and other traffic control devices. The contractor's representative must be available 24/7 and can be on-site within 60 minutes of notification.

**2.6 COOPERATION WITH UTILITIES.** The Contractor will notify all utility companies, all pipeline owners, or other parties affected, and endeavor to have all necessary adjustments of the public or private utility fixtures, pipelines, and other appurtenances within or adjacent to the limits of construction, made as soon as practicable.

The Contractor shall comply with the requirements of the Blue Stake one call system, in notification to the interested utility owners prior to start of construction. The Contractor shall resolve all problems with the utility owners concerned.

Where water user's association facilities obstruct construction of the work, the Contractor shall contact officials of the association relative to the shutdown of irrigation water and shall acquaint himself with and conform to the requirements of the association.

Water lines, gas lines, wire lines, service connections, water and gas meter boxes, water and gas valve boxes, light standards, cable ways, signals, and all other utility appurtenances within the limits of the proposed construction which are to be relocated or adjusted by or under the direction of the facility owners at no expense to the city.

**2.7 COOPERATION BETWEEN CONTRACTORS.** The City reserves the right at any time to contract for and perform other or additional work on or near the work being done.

When separate contracts are let within the limits of any one project, each Contractor shall conduct his work so as not to interfere with or hinder the progress or completion of the work being performed by other Contractors. Contractors working on the same project shall cooperate with each other as directed by the city's representative.

Each Contractor involved shall assume all liability, financial or otherwise, in connection with his contract and shall protect and save harmless the Public Agency from all damages or claims that may arise because of inconvenience, delay, or loss experienced by him because of the presence and operations of other Contractors working within the limits of the same project.

The Contractor shall arrange his work and shall place and dispose of the materials being used so as not to interfere with the operations of the other Contractors within the limits of the same project. He shall join his work with that of others in an acceptable manner and shall perform it in proper sequence to that of the others.

**2.8 CONSTRUCTION STAKES, LINES AND GRADES.** The Project Engineer will set construction stakes establishing lines and grades for road work, curbs, gutters, sidewalks, structures and centerlines for utilities and necessary appurtenances as may be deemed necessary. The Project Engineer (or the Developer) will furnish the Contractor all necessary information relating to the lines and grades. Such stakes and marks shall constitute the field control by and in accordance with which the Contractor shall establish other necessary controls and perform the work. A copy of the field notes shall be submitted to the city's representative upon request.

The Contractor shall perform the work in accordance with construction stakes and marks,

and shall be charged with full responsibility for conformity and agreement of the work with such construction markings. When obvious errors or conflicts occur in the staking, the Contractor shall stop work and immediately notify the Project Engineer or the city's representative.

The Contractor shall be held responsible for the preservation of all stakes and marks, If the construction stakes or marks have been carelessly or willfully destroyed or disturbed by the Contractor, the cost for replacing them will be borne by the Contractor.

**2.9 USE OF EXPLOSIVES.** The use of explosives or blasting is generally not allowed within the city, however, if explosives or blasting are permitted, their use is controlled by the Uniform Fire Code. The Contractor shall obtain a special permit from the City for the use of explosives. The approval by the city's representative for the use of explosives shall not relieve the Contractor from his responsibilities for proper use and handling of the explosives or for all damages resulting from their use.

Explosives shall be transported, stored, handled, and used in accordance with the provisions and requirements of all applicable laws, ordinances, and regulations.

**2.9.1 PERMITS AND BLAST PLAN.** When any blasting is to occur within the city a permit for such activity shall be applied for at least three working days prior to the desired blasting day. A detailed blast plan shall be submitted for review at the time of application for a permit. The blast plan shall contain the following information:

- A. Number of holes per blast.
- B. Blast pattern.
- C. Depth of holes.
- D. Maximum holes per delay.
- E. Numbers of the delays used.
- F. Type of explosives used.
- G. Total pounds of explosives.
- H. Maximum pounds per delay.
- I. Method of detonation.
- J. Proximity to nearest structure.
- K. Expected duration of blasting activity.
- L. Name of independent monitoring company.
- M. Whether or not pre-blast survey is required and the name of the company doing such a survey.
- N. Plan outline for notification of Fire Marshal, Fire Chief, or governing agency one hour prior to detonation of each blast and approximate time of each blast.

**2.9.2 GENERAL BLASTING CRITERIA**

- A. Blasting activity that is to occur within one thousand (1,000) feet of any school (public or private), university, day care center, church, library, medical facility, or any public building shall be conducted during off hours where possible and shall require seismic monitoring of each blast to ensure the integrity of the building as well as the safety of the occupants of said buildings. Since there is a wide variety in the type



density, specific gravity, velocity, and general characteristics within the graphical area of southern Utah, there are varied methods that can be employed to attain the desired results. These methods, if used and however varied, shall adhere to the appropriate limit criteria.

B. Any blasting that is intended within five hundred (500) feet of any structure (building, tunnel, underground utilities, gas lines, overhead transmission lines, pump station, piping, radio tower or any structure of any kind) requires that the blast be monitored with a seismograph capable of measuring peak particle velocities in three spatial components of horizontal, vertical and transverse and be capable of printing this data into a permanent record as digital as well as wave form and air blast over pressure in terms of millibar, PSI or decibel (dB) recording of each event. Any structure such as residential homes, commercial buildings, public buildings, storage facilities, or any other permanent structure that lies within five hundred (500) feet of blasting activity shall be required to have a pre-blast survey performed at the expense of the Contractor and/or the blaster by an independent company whose primary nature of business is to conduct and perform these types of services. The said company shall furnish to the City a copy of the pre-blast survey report prior to issuance of the blasting permit. A certificate of insurance issued by an underwriter legally doing business within the State of Utah showing Contractor and/or blaster to be properly insured for the express purpose of blasting and showing the issuing agency as additional insured, shall be submitted with the application of the blasting permit. The amount of insurance shown on the certificate of insurance shall be in the amount required by City's Fire Department or Owner's Representative. A blasting permit shall be site specific and expire thirty days from issuance.

C. Furnish and erect special signs to warn the public of blasting operations. Said signs shall be located and maintained to be clear to the public during all critical periods of blasting operations.

D. Notify each public utility company, having structures or facilities adjacent to the work, of his intention to use explosives. Such notice shall be given sufficiently in advance to enable the companies to advise the Contractor of any precautions that should be taken to protect their structures from damage.

E. Make a survey of adjacent properties, before commencing blasting operations, locating on drawings and by photographs all existing cracks and damages to structures. A copy shall be filed with the Representative, including a report of any property owners who refused to cooperate and permit entry and inspection.

F. Blasting shall be accomplished in such a manner that nearby buildings, structures, railways, highways, etc. will be safe from rocks and other projectiles. Adequate blasting mats or other means of protection shall be employed when blasting in congested area or close proximity to any of the above improvements. Steel mats shall not be allowed within two thousand (2,000) feet of power lines.

G. Immediately prior to the time of firing, the Contractor shall station certified flaggers along the road(s) at sufficient distance from the blasting operation to

control traffic as required.

H. The City reserves the right to order the discontinuance of blasting operations at any time.

**2.9.3 LOGS.** The blaster shall, at the request of the City, surrender logs and records, or a copy thereof, for review within twenty-four hours of receiving such request. Failure to keep current and/or surrender the logs to the City will result in the immediate cancellation of all permits issued. No further permits will then be issued within thirty days of submission of said records.

**2.10 PROTECTION AND RESTORATION OF PROPERTY AND LANDSCAPE.** The Contractor shall be responsible for the preservation of all public and private property and shall protect from disturbance or damage all survey control land monuments and boundary marks. Prior to disturbing any monuments, the Contractor shall notify the City Surveyor who shall require said Contractor to hire a licensed Surveyor to properly reference the monument, unless otherwise directed.

When or where any direct or indirect damage or injury is done to public or private property by or on account of any act, omission, neglect, defective work or materials, or misconduct in his manner or method of executing the work, or in consequence of the non-execution thereof by the Contractor, he shall restore, at his expense and at no cost to the City, such property to a condition similar or equal to that existing before such damage or injury was done, by repairing, rebuilding, or otherwise restoring as may be directed, or he shall make good such damage or injury in an acceptable manner. Said responsibility shall not be released until the project has been completed and accepted.

The Contractor shall not dump spoil or waste material on private property without first obtaining written permission from the property owner. All such dumping shall be in strict conformance with the Grading and Drainage Ordinances.

Prior to any construction in front of driveways the Contractor shall notify the property owner twenty-four hours in advance. Inconvenience caused by construction across driveways and sidewalks shall be kept to a minimum by restoring the serviceability within twenty-four hours, or as otherwise approved by city's representative. If it is necessary to leave open excavation for a longer period, the Contractor shall provide structurally adequate steel plates to bridge the excavation.

**2.11 SURVEY MONUMENTS.** Class I or Class II survey control monuments (as shown in the standard drawings of these specifications) shall be installed on all dedicated and private streets. All survey control monuments shall be installed in strategic locations (as determined by the city's representative) to ensure adequate survey control required for subsequent resurvey in the area.

All Class I monuments shall be cross tied and referenced to permanent features and mapped sufficiently for future use in relocation and replacement. All cross-tie information shall be submitted to the City Surveyor and should also be kept in a permanent record by

the Professional Surveyor doing the work.

Any section, witness or reference corners which fall within roadway or parking lot construction areas shall be reset with a Class I type monument with appropriate cap (as shown in the standard drawings). All corners being replaced shall be referenced in a manner as to accurately reset the corner. A copy of the field notes shall be submitted to the appropriate public agency surveyors for approval before corners are destroyed. The appropriate public agency surveyors (city or county) shall give direction on requirements for referencing of corner(s) to be replaced and the method of reinstallation prior to corner(s) being destroyed.

**2.12 HAZARDOUS MATERIALS DISCOVERIES.** If suspected hazardous materials (including chemicals, petroleum products, etc.) are encountered, construction operations shall be immediately stopped in the vicinity of the discovery and the proper authority shall be notified of the nature and exact location of the findings. The Contractor shall secure the site of the discovery and shall provide written confirmation of the discovery and proper notification to the city's representative within twenty-four hours. The written confirmation shall include a statement regarding responsibility to report the discovery to the local health district and the Utah Department of Environmental Response and Remediation within twenty-four hours as required by Federal Statute (40 CFR 280.50) as adopted by the State of Utah. The Contractor or the Property Owner shall then report the discovery as specified in the law.

After operations in the vicinity of the discovery have been restricted, the Property Owner shall keep the City informed concerning the status of the restriction. The time necessary for the Property Owner and appropriate Regulatory Agency to arrange for an acceptable solution to the discovered hazardous material situation is variable and dependent upon the nature and extent of the discovered materials. After clearance is received from the appropriate Regulatory Agency, the Property Owner shall inform the Contractor and the city representative when work may be continued in the vicinity of the discovery. Written confirmation shall be provided within two calendar days.

**2.13 IMPROVEMENT SEQUENCE.** Improvements shall generally be installed in the following sequence, unless otherwise directed or approved by the city's representative.

- A. Construction Traffic Control
- B. Rough grading
- C. Sanitary Sewer
- D. Storm Drainage
- E. Culinary Water
- F. Electrical Service
- G. Telephone
- H. Cable T.V.
- I. Natural Gas
- J. Sub Grade
- K. Sub Base
- L. Road Base

- M. Curb and Gutter
- N. Asphalt and/or Sidewalks
- O. Street Signs and Pavement Markings
- P. Manholes frames & covers, and Valve boxes and covers raised to Grade
- Q. Survey Monuments
- R. Clean-up

Please note that this is a general sequence and is not intended to cover all aspects or steps of the construction work.

## SECTION 3

### DESIGN STANDARDS

**3.1 INTRODUCTION.** This section defines design requirements for public improvements. It is not the intent of these standards to restrict professional judgement, but rather to serve as a guide and to establish consistency in design.

These standards are the minimum required and should be considered as such. It is recommended that the Engineer in charge review each project on its own merit and impose a higher professional standard as necessary for each project. These requirements apply as required by the Subdivision Ordinance.

**3.2 STREET DESIGN.** All streets shall be designed to conform to the standards and technical design requirements contained within this sub-section. The American Association of State Highway and Transportation Officials (AASHTO), shall be used as a supplement to these guidelines. In cases of conflict, a determination shall be made by the City representative, which determinations shall be final.

**3.2.1 STREET CROSS-SECTION STANDARDS.** Requirements for the street cross-section configurations are shown in Table 3.1. These requirements are based on traffic capacity, design speed, projected traffic, system continuity and overall safety.

All new developments shall use street cross-sections with fifty feet (50) or more of right-of-way. Access to multi-family or commercial developments, shall use street cross-sections with sixty (60) feet or more of right-of-way.

Alternate road cross-sections incorporating the use of a planting strip may be permitted if applicable safety and traffic standards are met and approved by the Planning Commission.

**3.2.2 ROADWAY NETWORK DESIGN.** New roadway networks shall be designed in accordance with the general planning concepts, guidelines, and objectives provided within this sub-section.

- The "Quality of Life" for residential occupants shall be a primary concern when designing a residential roadway network.
- An emphasis on proper street hierarchy should be adhered to, namely, local streets should access residential collectors; residential collectors should access major collectors; major collectors should access minor arterial; etc.
- An emphasis on access management should provide control of the location, design, and operation of all driveways, median openings, and street connections to a roadway.

- Roadways should be designed in a curvilinear method to reduce, or eliminate, long straight stretches of residential roadways which encourage speeding and cut through traffic.
- Substantial increases in average daily traffic, due to development of adjacent property on established streets not originally designed to accommodate such increases should be avoided.
- Drainage methods should concentrate on meeting the drainage needs while not impeding the movement of traffic (see drainage guidelines).
- Roads should be designed to lie within existing topographic features without causing unnecessary cuts and fills.
- A reduction in the use of cul-de-sacs should be emphasized to provide greater traffic circulation and less volume on collector roads. Circulation is of the utmost importance. Long blocks and excessive dead-end streets should be avoided.
- Stopping sight distance must be considered at all intersections and curves to ensure the safety of the public, in accordance with AASHTO standards.
- Unless otherwise approved by the city engineer all roads must comply with Appendix D, Fire Apparatus Access Roads most current version.
- Active Transportation (pedestrians and bicycle traffic) should be considered in the planning and design of all developed streets.

**TABLE 3.1  
STREET CROSS-SECTION CONFIGURATIONS**

Classification	Minimum ADT or [D.U.'s]	Traffic Index	Curb Type	Maximum Grade (%)	Right of Way (feet)	Pavement Width <sup>1</sup> (feet)	Sidewalk Width (contiguous) (feet)	Planter Strip Width, PUE
Residential Local	20 to 500 [2 to 50]	5	high back	15	44 <sup>2</sup>	29	5'	N/A
Residential Local Alt.	20 to 500 [2-50]	5	modified	15	50 <sup>2</sup>	29	5'	5'
Residential Standard	150 to 1,500 [15 to 150]	5	modified	15	50 <sup>2</sup>	35	5'	N/A
Minor Collector	1,260 to 2,000 (126-200)	6	modified	12	60	45	5'	N/A
Major Collector <sup>4</sup>	2,001 to 6,000 [201 to 600]	6	high back	12	66	49	6 <sup>3</sup>	N/A
Minor Arterial <sup>4</sup>	6,001 to 20,000 (601-2,000)	8	high back	10	80	63	6	10'
Minor Arterial Alt.	6,001 to 20,000 (601 to 2,000)	8	high back	10	80	55	5'	5'
Major Arterial	20,000+ (2,000+)	8	high back	10	95	77	6.5'	N/A
Commercial Local	NA	10	high back	8	60 <sup>5</sup>	43 <sup>5</sup>	6'	N/A
Industrial Local	NA	10	high back	6	66 <sup>5</sup>	49 <sup>5</sup>	6'	N/A

\*\*Note: Sidewalk easements are required.

- 1 Pavement width measured from lip of curb to lip of curb.
- 2 A wider planter strip may be placed if a sidewalk easement is provided and a 20' minimum setback from the back of the sidewalk is required.
- 3 A 10-foot planter strip may be placed between back of sidewalk and any wall, fence, hedge, etc. This area can be private or public. If public, a 72-foot right-of-way will be required. Alternate sections with meandering sidewalks may be proposed.
- 4 Configuration of major collector and higher classifications may be adjusted with proper justification and approval of city representative.
- 5 The minimum right-of-way and pavement width is shown. Each may be increased when required by a traffic impact study.

**3.2.3 IMPROVEMENT REQUIREMENTS.** All improvements including, but not limited to the following, shall be constructed in accordance with the standard specifications and drawings unless otherwise approved.

**3.2.3.1 Curb, Gutter, and Sidewalk.** Required curb, gutter and sidewalk shall be constructed.

**3.2.3.2 Driveways.** Driveways shall be constructed only in approved locations. No driveways shall be constructed unless an approved site plan has been submitted.

**3.2.3.3 Pavement.** All streets, public or private, shall be surfaced to grade, with asphalt concrete pavement, to the required minimum width and thickness in accordance with these specifications.



**3.2.3.4 Street Lighting & Power.** Street lighting shall be provided on all streets. The construction on public streets shall be in accordance with the standard drawings and these specifications. Standard Public streetlights may be installed on private streets upon agreement with the City and the local power agency when applicable. (Reference to Washington City Underground Power Construction Standards and Specifications.)

**3.2.3.5 Cross Gutters.** No cross gutters shall be allowed across major collector or major and minor arterial streets. On commercial and industrial streets, cross gutters are generally not allowed and require approval by the City representative for their use. The city representative may prohibit construction of cross gutters on any street deemed necessary.

**3.2.3.6 Disability/ADA Ramps.** When new construction occurs handicap ramps shall be constructed at all street intersections in accordance with current ADA standards, unless otherwise approved, in accordance with the standard drawings. In addition, when a project occurs where existing improvements are in place, handicap ramps shall be upgraded to meet current ADA standards.

**3.2.3.7 Paved Roadway Medians.** Medians on public roadways may be allowed when approved by the city representative. Design and construction shall be in accordance with applicable standards.

**3.2.3.8 Minimum Access.** Proposed developments shall have only the required number of accesses to adequately address the needs of the development and only at approved locations. Too many access points or access on major routes hinder the safety and efficient travel of vehicles using these routes. In addition, too few accesses can stifle circulation and unnecessarily concentrate traffic at selected locations.

**3.2.3.9 Drainage.** Adequate drainage facilities shall be installed to properly conduct runoff from the roadway. Sub-drains and surface drainage facilities shall be designed in accordance with the approved drainage study. Cross gutters shall be used sparingly to maintain the public's driving comfort and in accordance with these specifications.

**3.2.3.10 Traffic Control Devices.** Appropriate traffic control devices and street signs, as required by the city representative, shall be installed in accordance with the MUTCD.

**3.2.3.11 Pavement Marking.** Appropriate pavement markings, as required by the City shall be installed in accordance with the MUTCD.

**3.2.3.12 Street Trees and Landscaping.** Appropriate street tree and landscaping as required by the City shall be in accordance with Santa Clara City Ordinance.

**3.2.3.13 Other Improvements.** The above required improvements are not all inclusive. Other improvements needed to complete the development in accordance with current engineering and planning standard practice may be required by the city representative.

**3.2.4 TECHNICAL DESIGN REQUIREMENTS.** The following requirements apply to public streets.

**3.2.4.1 Street Grades**

A. All street grades shall have a maximum grade as shown in Table 3.1

B. A written request to increase the maximum street grades shown in Table 3.1 maybe considered upon submittal of a request and information justifying such a request to the City representative. Request for approval must be based upon and in accordance with the latest edition of AASHTO's A Policy on Geometric Design of Highways and Streets guidelines. Any approvals for increased grades must be consistent with access requirements of fire apparatus as defined by the Fire Department. The city representative's decision will be final. Cost of construction will not be justification for approval.

**3.2.4.2 Intersections**

A. All street intersections should intersect at ninety-degree angles.

B. In the event an acute angle intersection is proposed, the city representative may require mitigation by realigning to achieve a ninety-degree intersection. If no other reasonable option for realignment exists, a skew may be allowed up to a maximum of 15 degrees from 90 degrees. Other design approaches to mitigate the skewed angle may be required by the city representative.

C. Proper combination of horizontal and vertical alignment should be obtained by engineering study and consideration of the general guidelines listed in AASHTO (Section Titled: Combination of Horizontal and Vertical Alignment, current edition).

D. Intersections should not be located on the interior of, or near, sharp curves. Intersections should be located a sufficient distance from all curves to provide minimum sight distance for vehicles on the intersecting road or driveway and on the through road.

E. New intersections with more than four legs are generally not permitted. For arterial access, only four-leg intersections, T intersections and modern roundabouts are permitted. When designing local road networks, T and L intersections are desired. The L intersection (knuckle) will only be permitted when the street length, in either direction from the angle point, is six hundred feet (600), or less. Four-leg intersections on local road networks are generally discouraged. Where determined that a four-leg intersection is necessary, approval from the City representative shall be obtained prior to final design of

the local road network. Exceptions to these requirements may be granted by the city representative on a case-by-case basis. The developer's engineer must provide acceptable compelling Traffic Engineering analysis justification before deviations will be granted.

F. When designing local road networks, block lengths without an intervening connector street shall not exceed eight hundred feet (800') in length unless previous approval has been obtained from the city representative. Cul-de-sacs are not considered an intervening connecting street.

G. New access locations created by development shall be unified whenever possible to create the fewest number of access points onto arterials or major collectors. Cross use or shared access agreements shall be required where necessary.

H. Access to corner lots should be from the lesser-classified road at the greatest distance possible from the intersection and should not be less than the distances shown below. This distance is measured from the PI of the corner curve as measured along the back of the curb. A 25' radius is considered the minimum where the existing radius is less than 25'.

**TABLE 3.2  
FACILITY TYPE  
ACCESS DISTANCE FROM CORNER (IN FEET)**

Facility Type	Access distance to edge of driveway
Residential Local	50
Residential Alt.	50
Residential Standard	50
Minor and Major Collector	175
Minor and Major Arterial *	200

\*All access points shall be approved by the city representative. Distances shown may be increased as required by the city representative on a case-by-case basis. Exceptions can only be approved by the city representative upon SUBMITTALS of proper traffic justification.

I. The intersection of two local roads should be designed to operate with minimal traffic control devices. For example, do not design an intersection to operate with a four-way stop or signal control.

J. Direct access will not be allowed for parking, loading or driveway areas that require backing maneuvers onto major collector or higher order streets. This

requirement shall apply to commercial and industrial use regardless of the order or classification of street.

K. Residential and commercial developments are generally required to provide at least two improved accesses to the development depending upon the forecasted traffic volumes. Adjacent developments may be required to combine or share driveway access to public roadways. The access shall be of proper width to accommodate the calculated traffic volumes and expected vehicle types when the area is fully developed and shall be in accordance with the Zoning Ordinance. Projected traffic volumes shall be calculated using the criteria outlined within the Traffic Impact Study requirements of these specifications.

L. Covered driveways will not be allowed unless approved by the city representative.

M. The minimum curb radius allowed for a residential street at the Point of Curvature shall be 25 feet. Roads with asphalt width of more than 35 feet, or roads connecting to a road with more than 35 feet of asphalt in width, shall have a minimum radius as determined by the City. All radiuses are measured at the TBC (top back of curb).

#### **3.2.4.3 Intersection Spacing**

A. Street intersections shall be spaced far enough apart so that the existing and projected traffic stopped to make left turns at one intersection does not interfere with traffic movements at the adjacent intersection and to not hinder the capacity or safety of the roadway. When a street intersects a low volume residential street, the minimum distance is 150 feet. When a street intersects a minor or major collector street, the minimum distance is 250 feet. Minimum distance measurements are centerline-to-centerline. The minimum spacing requirement on arterials shall be as determined by the city representative. Locations shall be based upon several items such as projected volumes, turning and stacking distances, intersection spacing, traffic progression, etc. Generally, the minimum distance will be 650 feet for arterials and 1/4 mile for major arterials. The city representative shall review and give final approval to any intersection requests on arterials.

#### **3.2.4.4 Maximum Design Volume**

A. The maximum design volume shown on Table 3.1 shall be used unless otherwise approved by the city representative. A request to increase these volumes may be submitted for consideration to the city representative. This request shall include all necessary and required information including support and justification from the Traffic Impact Study.

Conditions which must be considered when reviewing a request for an increase in maximum design volume include hillsides, safety, parking, traffic studies, access requirements, etc.

### **3.2.4.5 Cul-de-Sac Streets**

A. Such streets shall not exceed eight hundred (800') feet in length as measured from center of cross street to center of cul-de-sac. The turn-around pavement radius shall not be less than forty-two and one-half feet (42' – 6"), or (50 feet at property line). Commercial pavement radii shall be no less than forty-seven and one-half feet (47' – 6"), or (55 feet at property line). No road shall be ended without a properly designed cul-de-sac turnaround unless otherwise approved by the city representative. Major collectors and higher order roads shall not be permanently dead ended.

### **3.2.4.6 Sidewalks**

A. Sidewalk (pedestrian access) shall be required in all residential and commercial developments. See Table 3.1.

B. For developments which are within hillside areas, see the City of Santa Clara Hillside Ordinance.

C. Sidewalks in areas of high pedestrian traffic may require a greater width as determined by the city representative.

D. Sidewalks in the designated "Streets project area" ord. 16.24.060 or adjacent to the "streets project area" are allowed 4' sidewalks or as determined by a city representative.

### **3.2.4.7 Curb and Gutter**

A. All public or private streets shall use curb and gutter of the type shown in standard drawings unless otherwise approved by the city representative. In large subdivisions, in rural or agricultural settings, the curb and gutter may be eliminated (although the use of the rural curb is recommended) unless required for drainage or street continuity. When eliminated, roadside drainage and shoulder shall be as shown in standard drawings.

### **3.2.4.8 Plant/Landscape Strips**

A. Plant or landscape strips within a road right-of-way must be landscaped with at least twenty-five percent (25%), by area, of live vegetation. Lawn is not allowed within a plant or landscape strip less than 8 feet in width. Lawn areas shall be limited with a focus on a drip irrigation design with native plants and trees as per city ordinance #2022-05. The design of these areas must be approved by the city's representative or designee.

B. Planter strips shall not be filled with concrete or other hard surfaces.

C. Special drainage requirements may be imposed by city's representative to protect pavement and curb and gutter from damage due to irrigation of planter strips.

### 3.2.4.9 Design Speed

A. The design of geometric features such as horizontal and vertical alignment will depend on the design speed selected for each street. The design speed is primarily determined by the street function and classification and is the maximum speed for safe and comfortable operation of a vehicle. The use of design speeds other than those listed below must be approved by the city representative who may decide that the speed provided in this sub-section be changed to that which is reasonable and prudent under the conditions and having due regard to the actual and potential hazards.

**TABLE 3.3**

<b><u>Classification</u></b>	<b><u>Design</u></b>
Residential Local	25
Residential Local Alt.	25
Residential Standard	25
Minor Collector	30
Major Collector	35
Minor Arterial	40
Major Arterial	45
Commercial Local	30
Industrial Local	35

\* Variance of design speeds on residential collectors or higher order roads may be granted by the city representative to no greater (or less) than five MPH increments when conditions warrant. Variances will not be granted for short segments of roads, but for entire contiguous stretches so that consistency and driver expectancy are maintained, which will be reviewed on a case-by-case basis with approved design criteria.

### 3.2.4.10 Clear Sight Distance at Intersections

A. At intersections adequate clear sight distance should be provided to permit drivers entering the higher order street from a driveway or STOP-controlled intersection to see approaching traffic from a long enough distance to allow them to decide when to safely enter the higher order street and complete their turning maneuvers in advance of approaching traffic. Clear sight distance, for both left and right turning vehicles, should be in accordance with AASHTO guidelines and generally as follows:

**TABLE 3.4  
SIGHT DISTANCE AT INTERSECTIONS**

<b><u>Through Street Design Speed</u></b>	<b><u>Sight* Distance</u></b>
25	290
30	375
35	465
40	575
45	710
50	840
55	980

\*Sight distances should be adjusted with crossroad grades

### 3.2.4.11 Vertical Alignment

A. Vertical curves shall be provided in all changes in grade where the algebraic difference is greater than one (1).

B. Longitudinal street grades shall not be less than 0.75 percent unless adequate alternative street drainage is provided, nor more than fifteen percent, unless specifically approved by the city representative.

C. Vertical curve stopping sight distance design shall utilize criteria recommended by the latest edition of AASHTO. K-values shall be noted on all design drawings.

D. Minimum cross slope from street crown shall be two percent and the maximum four percent unless otherwise approved by the city representative.

E. Vertical alignment with the intersection is also of special nature, and design alternatives may be required. As a guideline, the approach area where vehicles stop while waiting to enter an intersection should not exceed five (5) percent from the gutter line of the street being intersected for fifty (50) feet, though a range of fifty (50) to one hundred (100) feet is more desirable. This applies to all intersections, except those where both intersecting streets are minor or major collectors. In this situation, the landing area for a residential and major collector which is controlled by a STOP or YIELD sign should be designed for a grade of three percent for one hundred feet. Any other major intersection streets shall be approved by the city representative.

### 3.2.4.12 Safe Stopping Sight Distance

A. The minimum sight distance (length of roadway visible to the driver) to be provided for through traffic traveling at, or near, the design speed to stop before reaching an object in its path shall comply with the requirements set forth below (AASHTO guidelines):

B.

**TABLE 3.5  
SAFE STOPPING SIGHT DISTANCE**

<u>Design Speed</u>	<u>Required Distance</u>
25	150
30	200
35	250
40	325
45	400
50	475
55	550



### 3.2.4.13 Horizontal Curves

A. The recommended minimum centerline radius for horizontal curves is outlined below.

**TABLE 3.6  
HORIZONTAL CURVES**

<u>Design Speed</u>	<u>Curve Radius in Feet</u>
25 MPH	185*
30 MPH	310
35 MPH	419
40 MPH	628
45 MPH	730
50 MPH	926

\* For residential local streets use 150.

### 3.2.4.14 Superelevation

A. Generally, Superelevation shall not be used on urban roads with design speeds less than thirty-five miles per hour unless otherwise approved by the city representative.

B. Maximum Superelevation for urban roads shall be four percent unless otherwise approved by the city representative.

C. The use of Superelevation shall require prior approval from the city representative.

### 3.2.4.15 Deceleration Lanes

A. Deceleration lanes may be required on streets in conjunction with driveways and/or intersections adjacent to a proposed development. They are specifically required when all the following factors are determined to apply:

B. 5,000 vehicles per day are using or are projected to use the street;

C. The 85th percentile traffic speed on the street is thirty-five miles per hour or greater; or forty miles per hour for a two lane (one lane each direction) roadway; and

D. Fifty vehicles or more making right turns into the driveway or street during a one-hour peak period.

The lane lengths for a deceleration lane shall be determined on a case-by-case basis and must receive prior approval of the city representative. In addition to the above guidelines, deceleration lanes may be required in connection with the results of a Traffic Impact Study or by the city representative.

### 3.2.4.16 Driveway Profiles

The slope of a driveway can dramatically influence its operation. Usage by large vehicles can have a tremendous effect on operations if slopes are severe. The profile, or grade, of a driveway should be designed to provide a comfortable and safe transition for those using the facility, and to accommodate the storm water drainage system of the roadway.

Suggested treatments of driveway grades are illustrated below. While 8 percent should be the maximum allowable initial grade (G1), maximum grades of 1 to 3 percent are preferable for high-volume driveways and 3 to 6 percent for low-volume driveways.

**TABLE 3.7  
DRIVEWAY TYPE/STREET CLASSIFICATION**

Driveway Type and Adjacent Street Classification	Maximum Range for G2 (Departure Grade)
Low Volume Driveway** on Local Street	-8% to 14%
Low Volume Driveway** on Collector Street	-4% to 8%
Low Volume Drive** on Arterial Street	-1% to 5%
High Volume Driveway*** on Any Street	-1% to 5%
<p>* The preferable grade of G1 is 3% to 6% for low volume driveways and 1% to 3% for high volume driveways.  ** Low Volume Driveway - defined as a driveway with less than 100 vehicles in the peak hour in the peak direction.  *** High Volume Driveway - defined as a driveway with more than 100 vehicles in the peak hour in the peak direction.</p>	
<p>Maximum suggested change in Grade: Initial Grade - Departure Grade 12% for any 10 feet of distance without a vertical curve.</p>	

### 3.2.4.17 Alignment and Continuity - Off-Site

A. Normally, off-site pavement construction requires asphalt concrete paving to the right-of-way centerline and in some cases beyond. When asphalt pavement is existing, the developer's engineer shall submit to the city representative sufficient information prepared by the Engineer to indicate vertical and horizontal alignments are maintained and adequate drainage is provided for. The developer may be required to replace all, or any portion of existing roadway, in a manner that two-way traffic can be maintained without the use of potentially hazardous alignment transitions (vertical or horizontal) and in a manner to ensure that adequate drainage is provided for. As a minimum, there shall be twenty-eight feet of paving to accommodate through traffic. Required parking and shoulders are not included in the 28 feet.

When off-site pavement construction consists of improvement to the right-of-way centerline (approximately), leading and trailing transition tapers shall be placed at each end of the improvements. Horizontal transition tapers shall be designed and constructed based upon the roadway speed and in accordance with the taper requirements in the MUTCD and applicable AASHTO guidelines unless otherwise approved by the city representative.

B. When paving for partial street construction, the edges of the pavement are to be protected by placing a minimum two feet of aggregate base material beyond the edge of pavement matching the pavement grade.

C. Wherever partial street construction is required, grades shall be set for the future curb line and approved by the city's representative. The future grades shall be compatible with the curb and centerline grades for the partial street construction. It shall be required to design the roadway for a minimum of two hundred (200) feet to as much as one thousand (1000) feet beyond the development to ensure a future match.

D. Where a street abruptly ends or transitions, proper signage according to the MUTCD shall be required. Safe transitions into existing elevations shall be required where new roads transition into existing surfaces, i.e., gravel or natural surface.

### **3.2.5 PAVEMENT STRUCTURAL DESIGN**

The structural details shown on the standard drawings are minimum requirements. The actual structural section for each roadway shall be designed by accepted Engineering design methods for flexible pavement (i.e., AASHTO, UDOT or CALTRANS). Required subgrade soil properties shall be obtained from an on-site geotechnical investigation. Required traffic information for design shall be approved by the city representative.

The geotechnical investigation shall be conducted by the Geotechnical Engineer. The investigation shall include a thorough exploration and sampling program of the subgrade to determine the nature and engineering properties of the on-site soils within the roadway construction area. For new construction and reconstruction projects, the minimum sampling and testing requirements are as follows.

- Excavate test holes to a minimum depth of ten feet below finished street . There shall be three (3) test holes for the first 1,000 feet and one (1) additional test hole for every six hundred feet thereafter depending on soil type.
- Calculate R values using AASHTO T 190-93 or ASTM D2844-69 (1975) using exudation pressure of 300 PSI (2070 Kpa) corrected to 2.50 inches (63.50 mm) specimen. Calculate CBR values using AASHTO T 193-93 three point using T 180 (Method D) for mold compaction with exceptions as listed in 5.1.1 through 5.1.3 of Test

Method T193-93.

- Minimum Testing Frequency for R or CBR values shall be as follows:  
Two tests with at least one test per significant soil type for roadway lengths of one foot to one thousand feet.
- Three tests with at least one test per significant soil type for roadway lengths of one thousand feet to five thousand feet.
- Four tests with at least one test per significant soil type for roadway lengths of five thousand feet to sixteen thousand feet.
- Two tests per five thousand feet of roadway with at least one per significant soil type for any roadway over sixteen thousand feet.
- Conduct sieve analysis using either AASHTO T27-91 or ASTM C136-95. One test for each stratum of each test hole.
- Calculate density in place using the drive-cylinder method ASTM D2937-83 or nuclear method ASTM D2922-93. Two tests per test hole.
- Calculate resistivity and pH using test methods AASHTO T-288-91 and AASHTO T-289-91. One test for each corrugated metal pipe culvert location.
- Expansion index of soils shall be determined using the ASTM D4829-88 test method. This test shall be conducted whenever potentially expansive soils are encountered in a test hole.

*The above schedule represents minimum sampling and testing requirements. The Registered Professional Engineer responsible for directing and controlling the geotechnical investigation shall analyze each project to determine actual sample locations, frequency and testing program beyond the minimums given above.*

The above testing and design requirements may be waived by the city's representative providing a prior development has already performed the above testing, design, and construction on the first half of the roadway in the same location. In this case the new development shall match the existing roadway section.

**3.2.6 CURB SIDE MAILBOXES.** All roadside mail boxes should be installed in accordance with applicable postal standards in the following locations: In areas where the sidewalk is next to the curb, install boxes behind the sidewalk so as to not encroach into the sidewalk; in areas where a planter strip is provided, mail boxes may be installed within the strip, provided no part extends into the sidewalk or beyond the back of the curb; in rural areas where no barrier curb is installed, a minimum clear zone of ten feet from the traveled way must be provided.

**3.2.7 SIGNS AND PAVEMENT MARKINGS.** All street name and traffic control signs and pavement markings required on the street system within a development or because of the development, shall be installed at the developer's expense in accordance with the standard drawings and MUTCD standards. A signing plan should be submitted with the engineering drawings; however, additional signing and traffic control may be added to the project as determined by the city's representative.

**3.2.8 UNDERGROUND WATER.** When underground water in or adjacent to the site is encountered by geotechnical investigation or during the construction work, the city's representative and the Project Engineer shall be notified immediately. The Project Engineer shall cause the necessary studies to be made and the required mitigation work to be installed. Do not ignore the situation!

**3.3 GEOTECHNICAL STUDY GUIDELINES.** The construction of all improvements is subject to the recommendations of a geotechnical investigation report. This information shall be submitted at the same time improvement plans are submitted to the City representative. The findings contained in the geotechnical report shall be used as the basis for the design and construction of the project improvements unless otherwise directed by the city's representative.

The geotechnical investigation shall be conducted by a Geotechnical Engineer. The report shall be sufficiently comprehensive to determine the location and nature of all soils within the project construction area.

**3.3.1 GEOTECHNICAL REPORT.** The Geotechnical Report required by the Santa Clara City Subdivision Ordinance, (Chapter 16.20.040) and the Zoning Ordinance, (Chapter 17.48.010) shall be prepared by a Utah Professional Engineer. A Geotechnical Report shall be required for all commercial and industrial projects, and all residential lots and subdivisions. If the geotechnical investigation was completed more than 3 years (1095 days) prior to the project submittal date, then it's no longer valid without a current update letter/report indicating the original investigation remains valid.

In addition to the requirements set forth in Chapter 18 of the 2000 International Building Code, the report shall include, but need not be limited to, the following information:

- A. A site plan(s) showing the general site vicinity, the project boundary clearly identified, the location of any existing or proposed structures within the site, and the location of exploration test pits and/or borings.
- B. A general description of the topography, drainage conditions, vegetation,

surface features such as rock outcrops, existing structures, debris, and unstable or wet surface conditions.

- C. A description of the proposed structure(s) and improvements to be constructed on the site, as well as anticipated structural loads.
- D. Continuous logs of all test pits/borings. Soil classification shall be by the Unified Soil Classification System. Elevations, when possible, shall be shown on the tops of explorations on the same elevation datum as the project improvement plans. Elevation and depth of groundwater, if encountered, shall be shown. A description of the exploration and sampling methodology shall be provided.

The minimum exploration requirements are as follows:

- D.1 For single lot projects, a minimum of 2 (two) test pit/boring shall be provided. Additional test pits/borings shall be provided for larger projects at the discretion of the city representative.
  - D.2 For subdivisions, a minimum of 1 (one) test pit/boring on each proposed lot.
  - D.3 For proposed planned unit developments, a minimum of 1 (one) test pit/boring per one-half (1/2) acre of total area within the planned development not designated as open space areas, and 1 (one) test pit/boring per 300 to 600 lineal feet of public street proposed for construction.
  - D.4 For street improvement projects, a minimum of 1 (one) test pit/boring per 300 to 600 lineal feet of public street proposed for construction shall be provided.
  - D.5 Exploration depths shall be a minimum of 20 feet below the proposed ~~base~~ floor elevation, including basements, in building areas and 10 feet below the finish street grade elevation in public street areas.
  - D.6 In areas where highly expansive soil of encountered have known to exist, geotechnical investigations shall be based upon a minimum of 3 test pits/borings, with at least 1 test pit/boring on each lot. A highly expansive soil consists of a soil/rock that expands/swells a minimum of 8 percent (under a 60 psf surcharge) with the addition of water. Each exploration shall extend 5' minimum into the expansive soil layer, or 20' minimum total depth, whichever is less.
- E. An evaluation of the site for the presence of potential geologic hazards such as expansive soils, compressible/collapsible soils, gypsiferous (soluble) soils, uncontrolled fills, shallow groundwater, landslides, and stability of slopes. The extent of any geological hazards identified on the site shall be mapped and

addressed in the geotechnical investigation including any required mitigation.

- F. An evaluation of possible impacts of the proposed development on adjoining properties, and any mitigating measures that should be undertaken. Some impacts to be considered are: (a) extensive cuts and fills and associated slope stability; (b) surface drainage; and (c) the addition of subsurface water in sensitive soil areas.
- G. Laboratory test results. Laboratory testing shall be conducted, according to American Society for Testing Materials, (ASTM) Standards, to evaluate the nature and engineering properties of the subgrade soils.
- H. Conclusions and recommendations which shall contain, but not be limited to, the following information:
  - H.1 Site preparation and grading requirements, including the suitability of on-site soils for use as fill material, fill placement procedures, and compaction requirements, etc.
  - H.2 Geotechnical design considerations for drainage structures and/or erosion control, if applicable.
  - H.3 Procedures for mitigation of any potential geological hazard, such as special foundation systems (in accordance with Ordinance No. 96-25), groundwater control, and any special grading recommendations such as over excavation and re-compaction, etc.
  - H.4 For design recommendations involving expansive soils, the soils engineer shall use a wet depth model based upon the current load standard of practice. Suitable foundation types, with allowable bearing pressures and estimated settlements.
  - H.5 Slope grading recommendations for stable cut and fill slopes.
  - H.6 Design recommendations for street improvement areas, which shall include pavement design recommendations, sub-grade preparation, suitability of the on-site soils for use as pipe bedding, pipezone, and general backfill materials, and trench excavation and stability.

**3.4 DRAINAGE AND FLOOD CONTROL DESIGN** All ~~development~~ in the City that requires a grading permit or exceeds one (1) acre in area, as well as all commercial development, shall submit a Drainage and Flood Control Plan and Report.

**3.4.1 GENERAL REQUIREMENTS.** All development in the city that requires a grading permit and all commercial development that exceeds one acre in area shall submit a Drainage Control Plan and Report.

Design of drainage systems associated with development cannot cause increases in the flood peak discharges downstream from the development for 10-year and 100-year flood events.

Drainage and flood control shall be designed in conformance with the Washington County Flood Control Authority Storm Drainage Systems Design and Management Manual and the City Storm Water Master Plan.

Drainage facilities shall be designed using currently accepted civil engineering standards of practice, applicable safety standards, and City or other approved design specifications.

In general, each development should handle its storm water runoff in such a manner that no increase in the 10 or 100-year peak storm runoff above the predevelopment and/or natural state will occur on downstream properties.

In general, development changes the characteristic (quantity) of drainage from sheet flow to point discharge flow. While the amount of water may be controlled, the effects of all point discharges must be handled to insure no detrimental effects downstream of development.

Drainage facilities should be analyzed, designed, and constructed to protect the development from the 100-year peak storm runoff. Most drainage collection system capacities for new development will be sized for the 10-year flood event, but no significant damage or risk of personal injury may occur from the 100-year flood. Major hydraulic structures (including bridges, large culverts, and open channels) will be designed for the 100-year flood.

For analysis purposes of the drainage system of a drainage basin area, all of the drainage basin upstream of the proposed development should be analyzed for the conditions of new and/or planned development in conformance with the City's current Land Use Master Plan. Effects on downstream property owners and downstream flood control system shall be considered in the design and any negative impacts mitigated or design changes presented to mitigate problems to the satisfaction of the City Engineer or designee. This may include acquisition of easements or agreements and/or construction or modification of existing improvements where needed both within the development and/or downstream.

All storm drainage and flood control systems shall be separate and independent from the sanitary sewer system.



New development should not cause a natural drainage channel with a 100-year flood flow rate in excess of 500 cfs to be filled in, obstructed, or diverted without a floodplain development permit. When modifications to a natural drainage channel is proposed within the development, such changes will be addressed in the Drainage Control Plan and Report and shown on the improvement plans and must be approved by the City Engineer prior to proceeding. In the event that modifications to natural drainage channels are approved, necessary easements and rights-of-way for structures and improvements shall be provided to the City.

The point at where the natural drainage channel enters and leaves the property will not be changed without approval of the City Engineer.

Development of any kind should not cause a natural drainage channel to be filled in, obstructed, or diverted. When modifications to a natural drainage channel are proposed within the development, such changes will be addressed in the Drainage Control Plan and Report and shown on the improvement plans and must be approved by the city representative prior to proceeding. If modifications to natural drainage channels are approved, necessary easements and rights-of-way for structures and improvements shall be provided to the City.

Improvements designed to protect a development shall be considered permanent and shall be designed and constructed accordingly. Such improvements shall be maintained by the property owner or the agreed upon maintaining agency.

Development shall provide the necessary means to ensure drainage within the property being developed makes use of existing facilities and/or natural washes and shall be required to construct appropriate Flood Control Master Plan improvements that meet City design standards and proper flood control requirements.

**3.4.2 EROSION CONTROL.** Necessary measures shall be taken to prevent erosion due to drainage at all points in new developments. During grading and construction, the developer shall control all potential storm runoff so that eroded soil and debris cannot enter any downstream water course or adjoining property. All drainage that leaves a new development shall be adequately addressed to mitigate all erosion on adjacent properties and any increased flow due to development. Erosion mitigation shall be a permanent part of the final development plans unless otherwise approved. All drainage that leaves a new development shall be adequately addressed to mitigate all erosion on adjacent properties. Erosion mitigation shall be permanent unless otherwise approved. A comprehensive reference on erosion control is Sedimentation Engineering by the ASCE.

**3.4.3 IRRIGATION DITCHES.** In general, irrigation ditches shall not be used as outfall points for storm runoff drainage systems, unless such use is shown to not affect the performance of the ditch for its original intended use when substantiated by adequate hydraulic engineering analysis.

**3.4.3.1 USE OF DITCHES** - The irrigation ditches running through the area are laid out on very flat slopes and with limited carrying capacity. It is obvious, based on experience and hydraulic calculations, that irrigation ditches cannot, as a rule, be used as an outfall point for storm water drainage because of physical limitations. Exceptions to the rule are when the capacity of the irrigation ditch is adequate to carry the normal ditch flow plus the maximum storm water runoff with adequate freeboard to obviate creating a hazard to those below and around the ditch. Ditches are almost always totally inadequate for use as drainage ways.

Irrigation ditches are sometimes abandoned in areas after the agricultural land is no longer farmed. Provisions must be made for ditch perpetuation prior to its being chosen and used as an outfall for storm water drainage. Use of irrigation ditches for collection and transportation of storm water runoff shall be made only when approved by the city representatives or designee. Use of irrigation ditches for collection and transportation of storm runoff shall be made only when in accordance with the basin master plan.

**3.4.3.2 Irrigation Company Approval.** Any use of, alteration of, or relocation of structures on any irrigation ditch (or canal) shall have the written approval of the irrigation company who shall take the responsibility thereof.

**3.4.4 WATER QUALITY CONTROL.** Storm water may be considered a non-point source of pollution. It can carry materials that may cause unwanted physical, chemical, and biological changes in receiving waters (i.e., Santa Clara River). As such, a development should construct storm water facilities to control

pollutant concentrations and mass loadings discharged into receiving water systems. Some water quality parameters resulting from material transported in storm water that are of concern are sediments, hydrocarbons and oils, oxygen demand, bacteria, nutrients (carbon, nitrogen, and phosphorus), metals and other toxic chemicals. Receiving waters can assimilate only a limited quantity of different storm water materials. After a threshold is reached, the material becomes a pollutant that can result in an undesirable impact on the receiving water.

Federal and state regulations may limit pollutant concentration and mass loading to receiving waters from non-point sources. Technical considerations in design should be given to prevention or reductions of non-point sources of pollution by developments. Consideration should be given to the use of storm water management systems within developments that will reduce non-point sources of pollution such as off-line retention (infiltration) ponds, sedimentation ponds, wetlands that pass storm water through them, and reuse ponds. A goal for development should be to provide a storm water system that will have post-land-use mass loadings that are equivalent or less than pre-land-use mass loadings.

**3.5 SANITARY SEWER DESIGN.** This sub-section sets forth the criteria for engineering design of wastewater collection systems. All wastewater lines shall be designed to be in roadways or other vehicle travel ways unless approved by the Wastewater Division Manager. Minor additions, renovations and repairs to an existing sewer or plumbing system shall be permitted in the same manner and arrangement as in the existing system, provided that such repairs or replacements are not hazardous and are approved by inspection. All sewer main lines installed in public or private streets shall be inspected in accordance with these Standard Specifications for Design and Construction. These lines are public lines unless otherwise approved by the city representative.

**3.5.1 DESIGN FLOWS.** All sanitary sewers and appurtenances shall be designed to carry the design flows from all contiguous areas which may, within a reasonable period in the future, be tributary thereto. Trunk lines shall be designed in accordance with the system master plan.

Sanitary sewers shall be designed to carry the peak discharge as specified below; also, all sewers shall be designed to transport suspended material to preclude the deposition of any solids in the sewer line.

New sewer systems shall be designed based on an average daily per capita flow of not less than one hundred gallons per day. Other flow rates, based on accepted engineering practice, may be submitted to city's representative for review and/or approval. Sanitary sewer systems shall be designed to prohibit infiltration and exfiltration. To provide for peak loads, sanitary sewers shall be designed to carry not less than the flow shown in Table 3.8 when running 2/3 full.

**TABLE 3.8  
SANITARY SEWER DESIGN FLOWS**

Laterals and sub mains gallons/capita/day	400
--	-----

Mains, trunks, and outfalls gallons/capita/day	250
---	-----

All sewers shall be designed and constructed with hydraulic slopes sufficient to give mean velocities (when flowing one half full) of not less than two feet per second, based on Manning's formula. As a minimum, Manning's "n" value shall be in accordance with pipe manufacturer's recommendation. An "n" value which will yield higher friction losses shall be used where disturbing influences are known or anticipated, such as disruption of flow by tributary inflows, varied pipe materials, etc. The minimum slopes to be provided shall be as shown in Table 3.9, unless approved otherwise by the city representative.

**TABLE 3.9  
SANITARY SEWER MINIMUM SLOPES**

SEWER SIZE (Inches)	MINIMUM SLOPE (ft/100 feet)
4	2.00
6	0.60
8	0.50
10	0.40
12	0.35
15	0.30
18	0.25
21	0.20
24	0.15

Under special conditions, when justifiable reasons are given, slopes slightly less than those required for the two feet per second velocity when flowing one half full may be permitted. Such decreased slopes will only be considered where the depth of flow will be 0.3 of the diameter or greater for the design average flows, and where computations of the depth of flow in such pipes at minimum, average and peak rates of flow are submitted showing the basis of design. The Design Engineer must furnish computations for velocities and depth of flow for grades more than ten percent (10%) and for extremely low flow situations.

Hydraulic jumps shall be avoided whenever possible. Where velocities greater than fifteen feet per second are attained, special provision shall be made to protect against displacement by erosion and shock.

**3.5.2 MINIMUM SIZE AND DEPTH.** No public sanitary sewer shall be less than eight inches in diameter except as otherwise permitted in this sub-section. Minimum size of house connections shall be four inches in diameter. Minimum size of commercial connections shall be six inches in diameter. Only one residence, structure, or building shall be served by each lateral connected to the public main (Uniform Plumbing Code, Chapter 3).

The design and installation of six-inch sewer mains not exceeding two hundred feet in length may be permitted for terminal sewers in cul-de-sacs and dead end or

private streets in subdivisions. The equivalent flow shall not exceed that of 15 residential units. Manholes shall be required at the terminal end of these six-inch mains.

Lateral size and slope shall be based on the number of fixture units. Up to ninety (90) fixture units shall be allowed per four-inch lateral line. Each lateral connected to the public main shall serve only one residence, structure, or building. No connection of any sewer lateral to buildings or structures will be allowed until all downstream sewer lines have been tested and passed and all associated manholes have been raised and collared at asphalt grade.

In general, sanitary sewers shall be designed to a minimum depth of nine feet to the pipe invert to facilitate basements. Depth of pipe shall be measured from top of back of curb at low side of property to be served, to permit sewer laterals from basements to be connected. Exceptions may be granted in subdivisions or areas in which houses without basements are to be constructed. In such case a note to that effect shall be made on the plat map and on all plans presented for approval. In no case shall sanitary sewers be designed for a depth of cover less than thirty-six inches over the top of the sewer pipe. All sewers shall be designed to prevent damage from super-imposed loads as well as trench loading conditions. When more shallow depths are unavoidable, consideration for approval may be given upon submittal of proper engineering design criteria to the city representative.

**3.5.3 ALIGNMENT.** All sanitary sewer mains shall be designed for uniform slope and alignment between manholes and shall be laid a distance of at least ten feet (horizontally) from any existing or proposed water main. If a sewer main cannot be laid at least ten feet from an existing or proposed water main, then the city's representative may authorize the implementation of the provisions of the appropriate section of the State of Utah Public Drinking Water Regulations.

All sewer laterals shall intersect the sewer main on the top third of the sewer main pipe as shown in the standard drawings.

**3.5.4 SERVICE CONNECTIONS.** Service connections to any public sanitary sewer shall be made only to a wye installed at the time of the sewer main installation or by a machine tap and approved saddle compatible with the main line sewer material in accordance with the standard drawings. Service connections shall be a minimum of ten (10) feet, measured horizontally, from any culinary water line. All connections and service lines must be watertight. All sewer clean-outs shall be made with a standard wye fitting. New subdivisions shall install a sewer lateral from the main sewer to each proposed lot. The lateral shall be located fifteen feet from the low side lot line, unless otherwise approved, and shall extend a minimum of five to a maximum of ten feet into the property. All lateral cleanouts on new construction shall extend two (2) feet above top back of curb or finished grade with a glue cap.

Service connections shall not be made to any sewer outfall line with a diameter

greater than fifteen (15) inches unless otherwise approved by the City's Representative.

All sewer laterals connected to public sewer mains shall conform to Table 3.10. Laterals shall not be connected into main line stub ends extending from manholes.

All restaurants, food service establishments and other buildings that use high amounts of grease or oil shall install grease traps approved by the city's representative and shall comply with city pretreatment standards. Multiple connections to a lateral are not permitted.

Under no circumstances shall swimming pool drains, roof drains, foundation drains, storm drains or sub-drains be connected to the sanitary sewer system.

**TABLE 3.10  
SANITARY SEWER LATERALS**

TYPE OF UNIT OR RESIDENCE	MINIMUM SEWER LATERAL SIZE (Diameter)	MINIMUM SLOPE
Single Family Residences	4 inches	2%
Townhomes (each unit)	4 inches	2%
Multi-family Condominiums	6 inches	1%
Commercial establishments	6 inches	1%
Mobile Homes	4 inches	2%
Apartments	<b>4 inches minimum (see note below)</b>	

**NOTE:**

1) Lateral size and slope shall be based on the number of fixture units in the apartment, in accordance with the Uniform Plumbing Code.

**3.5.5 MANHOLES.** Manholes shall be installed at all changes in grade, direction, pipe size or at all intersections; and at distances no greater than four hundred feet apart. All manholes shall be accessible to maintenance vehicles, and all sewer

easements shall provide at least twelve feet of unobstructed width. Drop manholes shall be provided for a sewer line entering a manhole at an elevation of two feet, or more, above the manhole invert. Floor troughs shall be furnished for all sewers entering manholes and shall be at least as deep as the full diameter of the sewer main in the manhole. Lines entering a manhole above the main trough but less than eighteen inches above the invert shall be provided with a slide inside the manhole to prevent sewage from getting into the manhole shelf and to minimize splashing of sewage.

A sewer main or service eight inches or larger connecting to an existing sewer main shall require a manhole at the point of connection. Where the junction consists of the same size sewers, a 0.2-foot drop shall be provided between the branch and main sewer. When a smaller sewer main joins a larger sewer main in a manhole, the top of pipe elevations shall match.

All manholes shall have eccentric manhole cones conforming to the detailed dimensions, construction details and materials as shown in the standard drawings. Sewer manholes for all sewer mains of less than twelve (12) inches in diameter shall be a minimum four feet inside diameter. For sewers mains twelve inches in diameter or larger or over twelve (12) feet in depth, the manholes shall be not less than five feet in inside diameter. When the sum of all pipe sizes connecting to the manhole totals 24 inches or greater, the manhole diameter shall be five feet or greater.

When a sewer line is installed in a development or in a phase of a development, the line may be extended up to three feet beyond the last manhole on the line. The open end of the extension (the Astub) shall be the bell end of the pipe and must be sealed with a water-tight plug to allow for future extension. The stub shall be grouted and sealed around the pipe as it exits the manhole, to promote a water-tight fit. Manhole sections shall be installed no less than 14 days after date of manufacture. Each manhole section shall be clearly marked on the inside with the name of the manufacturer and the date it was manufactured. All new manhole lids and replacement lids on existing manholes shall have a Santa Clara City emblem..

**3.5.6 UTILITY CLEARANCES.** The following clearances must be maintained between sewer lines and other utilities unless otherwise approved by the city representative:

- A. Utility clearances specified in applicable laws and codes shall be adhered to.
- B. Sewer mains should be placed lower than other utilities.
- C. Water distribution and sewage collection lines shall be laid in separate trenches, with at least ten (10) feet of separation measured horizontally.
- D. Where the water line is less than eighteen (18) inches over the sewer line,

where the water line is under the sewer line, and where the horizontal separation cannot be maintained because of physical obstructions, the water line shall be protected by construction of the sewer line with 1) ductile iron pipe; 2) water supply quality materials and joints; or 3) encasement with a minimum of two (2) inches of concrete. Each of these provisions shall extend ten feet on each side of the crossing. These provisions shall also be extended for other than ninety-degree crossings to the point at which the ten (10) foot separation between the water and sewer lines is achieved.

E. Sewer laterals and mains crossing under power, storm drain, telephone, traffic signal conduit and/or street lighting conduit shall have at least one (1) foot separation, measured vertically. The clearance for gas lines shall be five (5) feet horizontally. If the required vertical clearance cannot be met, as determined by city representative, a cushion of sand and cement slurry may be used to separate the utilities. Where use of sand and cement slurry are not practical, the Engineer may propose alternate methods.

F. The following clearances should be maintained between waterlines and other utilities:

- Water to phone lines/cable TV - five (5) feet
- Gas to water - five (5) feet
- Water to power - five (5) feet
- Water to irrigation - five (5) feet
- Water to wastewater - ten (10) feet horizontal and eighteen (18) inches vertical.
- Gas to power - ten (10) feet.

**3.5.7 SUSPENDED CROSSINGS.** When suspended crossings are required, adequate support shall be provided for all joints in the pipe utilized for the crossings. The supports shall be designed to prevent frost heave, overturning and settlement. Precautions against freezing, such as insulation and increased slope, shall be provided. Expansion jointing shall be provided between above ground and below ground sewers. For suspended crossings, the impact of flood waters and debris shall be considered. The bottom of the pipe should be placed no lower than the elevation of the one-hundred-year flood plain. When possible, the crossing supports shall be designed to allow for future adjustment in grade.

**3.5.8 PRESSURE (FORCE) MAINS.** The following defines design criteria and standards for pressure mains.

A. **Velocity:** A velocity of no less than three (3) feet per second shall be achieved at design flow. Calculation of pressure main velocity, design pressure, and hydraulic losses shall be submitted to the city's representative for approval.

B. **Air Relief Valves:** Where required, an automatic air relief valve specifically designed for raw sewage application(s) shall be placed in the force main to



prevent air locking.

C. **Slope:** To limit accumulations of gases, no segment of a force main shall have a zero slope. Wherever possible, low points which are subject to solids accumulation shall be avoided.

D. **Termination:** Pressure mains shall enter the gravity sewer system at a manhole. If necessary, provisions shall be made to direct or baffle sewage as it enters the manhole.

E. **Design Pressure:** The pressure main and fittings, including reaction blocking, shall be designed to withstand normal pressure, pressure surges (water hammer), and total (active and passive) earth loads.

F. **Suspended Crossings:** Pressure mains used for suspended crossings shall meet applicable requirements of SECTION 3.5.7.

G. **Hydraulic Losses:** Friction losses through pressure mains shall be based on the Hazen-Williams formula. For the Hazen-Williams formula, "C" '100 shall be used for unlined iron or steel and "C" '120 for all other materials. Turbulent losses at fittings, bends and valves shall be determined in a similar manner. The design data shall be submitted to City's Representative for review and prior approval.

H. **Thrust Blocks:** Thrust blocks and other restraints shall be included as necessary to secure the pressure main from movement.

I. **Identification Ribbon:** A pipe locator ribbon shall be placed no less than eighteen (18) inches above the top of pipe, centered along the entire length of the pressure main. The ribbon shall be green in color and shall have the clearly printed legend, "Buried Sewer Line Below", printed continuously along its length with minimum one-inch letters. The ribbon shall be not less than two (2) inches wide. For nonmetallic pressure mains, the locator ribbon shall have a metallic component, such as plastic-coated aluminum.

J. **Connection Into Existing Systems:** When connecting any sewer main or sub-main into an existing sewer system a plug shall be installed at the time the sewer is cut into, both on the downstream and upstream ends of the new line. The plug shall be a Cherne Gripper Mechanical Plug or approved equal. The plugs shall not be removed until the new sewer system is approved and accepted by the city's representative.

**3.6 CULINARY WATER DESIGN.** All culinary water mains and appurtenances within the City of Santa Clara shall be designed to provide for adequate future service for all contiguous areas which may, within a twenty-year period in the future, be tributary thereto. Water trunk lines shall be designed in accordance with the system master plan.

**3.6.1 DESIGN FLOW PRESSURE.** Water mains shall be designed to provide a minimum residual pressure of twenty (20) psi under maximum day demand conditions including designed fire flow (as called out in SECTION 3.6.7 of these Standards). A minimum of forty (40) psi residual pressure must be maintained under normal peak hour conditions without fire flow.

**3.6.2 FLOW DESIGN CRITERIA.** Flow design criteria shall conform to the requirements outlined in the current edition of the State of Utah Rules for Public Drinking Water Systems, Section R309-203 "Minimum Sizing Requirements" and R309-211 "Transmission and Distribution Pipelines". In any case where these specifications require a higher design standard than is contained in the referenced Rules, the higher design standard shall take precedence.

Peak instantaneous flow for outdoor use shall be assumed as follows:  
Indoor Peak Instantaneous Flow multiplied by two.

Peak instantaneous fire flows shall be added to peak daily domestic flows for distribution system design flow total.

Commercial or industrial areas may require special investigation to determine fire flow requirements. Existing and future static pressure and flow information used in the design must be approved by the Public Works Department city representative.

**3.6.3 MINIMUM SIZE AND DEPTH.** The minimum depth of cover (to the top of the pipe) for water mains shall be three feet below the final grade of the street with a maximum of 10 feet unless otherwise approved by the city representative. Where final grades have not been established, mains shall be installed to a depth great enough to ensure a minimum of three feet and a maximum of ten feet of cover below future grade. The water mains shall be sized to deliver the peak instantaneous flow rate as previously outlined. The fire flow requirements and pressures shall be as previously outlined. The size of the pipe shall also be based on a five (5) foot per second (fps) velocity maximum at peak instantaneous flows, without fire flows. However, the minimum water main size to be installed shall be eight inches in diameter unless otherwise approved by the Public Works Department city representative.

Departures from the minimum requirements will be considered only in special circumstances. Water mains in cul-de-sacs, internal streets within subdivisions, and other areas where water mains will not be extended in the future, may be six inches in diameter if that size water main meets the development's water demand requirements.

Any departure from minimum requirements identified above shall be justified by a network hydraulic analysis.

A fire hydrant shall not be connected to a main which does not have sufficient fire flow capacity.

In locations where the city has determined line size for the future based on a

Master plan Study, the master-planned line size will be installed.

**3.6.4 VALVES AND HYDRANTS.** The water system shall be looped, and valves shall generally be spaced such that a break in any one length of main will put no more than six hundred feet of main or more than two fire hydrants out of service (whichever is less) while maintaining adequate minimum service in the remainder of the water system during repairs, except for major transmission lines, where longer spacing may be allowed. All distribution mains connecting to larger transmission mains shall be valved at the connection. All fire hydrant runs shall also be valved at the distribution main. Valves shall generally be located at street intersection with four (4) valves at a cross intersection and three (3) valves at a Tee intersection.

**3.6.5 PRESSURE REDUCING VALVES.** Pressure reducing valves shall be installed on main lines where designated by the city representative. The standard design for these pressure reducing valves and vaults shall be provided by the City Public Works Department.

**3.6.5.1 SECONDARY PRESSURE REDUCING VALVES.** The locations of the high-water-pressure zones within the City can be located and identified upon request from the Public Works Department.

**3.6.6 FIRE HYDRANT SPACING AND LOCATION.** Generally, fire hydrants shall be spaced and located as follows:

- A. At each intersection, generally on the same sides of the street.
- B. In residential areas, fire hydrant spacing shall be no greater than five hundred feet and no house shall be more than two hundred fifty feet from a hydrant measured along a street access to the property being served.
- C. In multiple family areas, PD zones, industrial, business, or commercial areas, fire hydrant spacing shall require special investigation to determine the hydrant spacing per Appendix 111-B of the Uniform Fire Code (UFC). (Generally, spacing shall be no greater than three hundred fifty (350) feet and all commercial buildings shall be within one hundred seventy-five (175) feet of a hydrant.)
- D. Generally, hydrants shall be in line with extensions of the property line when located mid-block.
- E. Hydrants shall be placed no more than five (5) feet from the back of the sidewalk. Where sidewalk is not adjacent to the curb and a four (4) foot wide or wider planter area exists, the hydrant may be placed in the planter no closer than two feet from the back of the curb. Provide a five (5) foot elliptical radius

of clearance to adjacent obstacles with the lowest water outlet not less than eighteen (18) inches nor more than thirty (30) inches from the final ground elevation (see standard drawings). The "break-away" flange at the bottom of hydrants shall be installed so that it is at, or within six (6) inches above, final ground elevation.

F. All fire hydrants shall be owned and maintained by the Public Works Department and shall be installed on dedicated easements or public rights-of-way.

G. A fire hydrant shall be placed in the end of all cul-de-sacs or on dead end lines.

Fire hydrants shall not be located:

(1) within five feet of a driveway, power pole, light standard, or any obstruction.

(2) or, within three (3) feet of any block wall or fence when measured to the rear of the hydrant.

**3.6.7 FIRE FLOW REQUIREMENTS.** Under maximum day demand conditions, fire flow shall be at least seven hundred fifty (750) gallons per minute at any one hydrant with a total fire flow of at least one thousand five hundred (1,500) gpm at any combination of two hydrants in the area, and/or must meet the requirements of the Federal Insurance Service Office. The total system design shall be such that fire flows and normal peak instantaneous flow demand (as called out within this subsection) can be met while still maintaining a minimum pressure of twenty (20) psi at all points in the distribution system.

A maximum water velocity of ten (10) feet per second shall be utilized when designing for fire flows and/or other emergency conditions.

High density residential, commercial, or industrial areas shall require special investigation to determine fire flow requirements and hydrant spacing per the Uniform Fire Code (UFC).

Existing and future static pressure and flow information used in the design shall be approved by the Public Services Department.

### **3.6.8 MISCELLANEOUS WATER SYSTEM DESIGN CRITERIA.**

A. All public water mains shall be installed in a public right-of-way, dedicated roadway, or designated drainage way, with adequate access for maintenance vehicles. Pipelines will not be installed on back lot or side lot lines due to potential flood and other damage.

B. Dead-end mains shall be avoided wherever possible and if installed, shall not exceed six hundred feet. Hydrants shall be located at the end of dead-end mains and cul-de-sac mains for flushing purposes as well as for fire protection. Blow-off valves rather than fire hydrants are not desirable except where warranted by special circumstances as determined by the city representative. Blow-off valves shall be installed per the standard drawings.

C. Each building or lot shall be served by a separate line and meter except in PUD's as approved by the city representative. In some situations, a common tap and service line from the main to a manifold with two-meter setters and boxes may be installed to serve two adjacent properties. All lots shall have a minimum of three quarter (3/4) inch service line from the main to the meter box. Multiple housing of two units, or more, shall have a minimum of one (1) inch service. When there are more than two multiple housing units the service line shall be sized accordingly.

D. All service line taps shall be machine tapped at the time of the water main installation. Service lines shall be installed prior to testing and acceptance of the water main.

E. Water mains shall be laid at least ten (10) feet horizontally from any existing or proposed wastewater main. The distance shall be measured edge to edge. If necessary and where approved by the city's representative, SECTION 12.2.1 of the State of Utah Public Drinking Water Regulations can be implemented.

F. When a water main crosses over a wastewater main, the water main shall be laid at such an elevation that the bottom of the water main is at least eighteen (18) inches above the top of the wastewater main. When the water main cannot be as high as eighteen (18) inches above the wastewater main, the wastewater main shall be constructed of material with pressure conduit standards for ten feet on either side of the crossing.

G. All tees, bends, plugs and hydrants shall be provided with reaction blocking, tie rods, and/or joints designed to prevent movement, i.e., "mega lug" or approved equal.

H. Air release vacuum assemblies and blow-off valves shall be provided on all mains twelve inches in diameter and larger, where required, to prevent damage due to air accumulations.

I. All water lines shall require a twelve-gauge insulated THWN wire be installed with the line for locating purposes. The wire shall be installed and extended up at each valve, hydrant, and up each service into the meter box.

J. Sufficient valves shall be provided on water mains to minimize inconvenience and sanitary hazards during repairs. Valves shall be generally located as follows:

- (1) At intervals to isolate no more than two (2) fire hydrants at any time.
- (2) At minimum intervals of five hundred (500) feet in commercially zoned areas.
- (3) In residential areas to isolate a maximum of thirty services (approximately six hundred (600) feet).
- (4) A maximum of five valves will be required to isolate any location.
- (5) Valves shall not be in street gutters, valley gutters, or in driveways.
- (6) A valve is required at the end of all temporarily dead-ended mains. The valve location is to be a minimum of ten (10) feet upstream of the cap or blow off assembly.
- (7) Valved outlet(s) for future service laterals six (6) inches in diameter and larger may be installed when approved by the city representative. (Valved outlet installation approval does not constitute a water commitment.)
- (8) A shut off valve immediately adjacent to the water main shall be provided for all service laterals greater than two (2) inches in diameter and for all fire hydrant laterals.
- (9) The city representative may require additional valves as deemed necessary.

K. All fire protection riser connections shall comply with the current NFPA 13 standards.

### **3.6.9 NETWORK HYDRAULIC ANALYSIS.**

**3.6.9.1 WHEN REQUIRED.** The Public Works Department city representative may require that a network hydraulic analysis be conducted by the Engineer if:

- the project is a major subdivision with an internally looped system
- the project is in the higher elevations of a low static pressure zone.
- a high fire flow demand is required (greater than 1500 gallons per minute).
- there will be extensive irrigation.
- the new water plans will complete a loop on the current system, or
- as otherwise required by the Water Department city representative.

**DESIGN.** The consulting engineer should request the source hydraulic grade line (HGL) from the water department prior to the initial design where a network hydraulic analysis is required. The following information shall be submitted at the time of such a request:

- location, type of development, and the acreage or number of units with the development, and
- anticipated fire flow requirements, and
- the location where the proposed water distribution system is planned to tie into the existing system.

**3.6.9.2 SUBMITTAL FOR REVIEW AND APPROVAL.** The network hydraulic analysis shall be submitted with the project design for review. For larger projects, such as a major subdivision, obtaining network hydraulic analysis approval prior to submitting the water plan is preferred. The Public Works Department city representative shall, upon request, decide as to which submittal method must be followed.

The network hydraulic analysis submittal shall include two copies of the following items:

- the data input sheets, as well as the analysis results
- information about the development (i.e., type, number of acres, number of units, fire flow requirements, etc.)
- data sheet(s) outlining all assumptions (i.e., method used to assign demands to corresponding nodes and source HGL's used)
- map identifying pipe and node numbers and their locations
- fire hydrant locations
- the name and version of software used for the analysis
- elevations of junction nodes
- staging or phasing of development, and
- appropriate off-site demands.

**3.6.9.3 MISCELLANEOUS.** The roughness factors to be used in the analysis should be as follows:

- C equal to 100 for all unlined cast iron pipe
- C equal to 120 for existing pipe twelve inches, or less, in diameter
- C equal to 130 for existing pipe (150 for PVC) fourteen inches, or greater, in diameter
- C equal to 130 for new pipe (150 for PVC) regardless of diameter

For any other sizes or materials not covered by the above, the consulting engineer shall contact the Public Works Department city representative for guidance.

When identifying the fire flow available in a network hydraulic analysis, use the hydrant located at the development's weakest point (highest point in the development and/or last hydrant on dead-end main). Also, verify the hydrant is located at a junction node.

The elevations used in the network hydraulic analysis should be based on a project grading plan or the anticipated final elevation. If the final grading plan deviates significantly from the elevations used in the analysis, a revised analysis will be required.

A chart to be used as a guide to determine water consumption for various types of developments shall be obtained from the Public Works Department.

**3.6.10 SUSPENDED CROSSINGS.** When suspended crossings are required, adequate support shall be provided for all joints in the pipe utilized for the crossings. The pipe shall be adequately supported and anchored; protected from damage, freezing, overturning, and settlement; and accessible for repair or replacement. Precautions against freezing, such as insulation and increased slope, shall be provided. Expansion jointing shall be provided between above ground and below ground sewers. For suspended crossings, the impact of flood waters and debris shall be considered. The bottom of the pipe should be placed no lower than the elevation of the one-hundred-year flood plain. When possible, the crossing supports shall be designed to allow for future adjustment in grade.

The crossing shall conform to Standard Drawing #322 and to the rules from the latest version of the Utah Administrative Code. The Division of Drinking Water should be consulted before final plans are prepared.

**3.6.11 UNDERWATER CROSSINGS.** Underwater crossings shall conform to Standard Drawing #321 and to the rules from the latest version of the Utah Administrative Code. The Division of Drinking Water should be consulted before final plans are prepared.

A minimum cover of two feet or greater, as local conditions may dictate, shall be provided over the pipe. When crossing water courses which are greater than 15 feet in width, the following shall be provided:

- A. The pipe shall be of special construction, having restrained joints for any joints within the surface water course and flexible restrained joints at both edges of the water course.
- B. Valves shall be provided at both ends of water crossings so that the section can be isolated for testing or repair; the valves shall be easily accessible, and not subject to flooding; and the valve nearest to the supply source shall be in a manhole.
- C. Permanent taps shall be made on each side of the valve within the manhole to allow insertion of testing equipment to determine leakage and for sampling purposes

**SECONDARY WATER OR WASTEWATER REUSE IRRIGATION SYSTEM.** All secondary water irrigations systems shall be designed and constructed in accordance with



the requirements outlined for culinary water systems in SECTIONS 3 and 4 of these specifications. However, all valve box covers, and service connection covers shall bear the legend "Irrigation" to clearly differentiate between culinary and secondary systems. The pipe material shall be colored purple, or a discrete color different from the culinary water main. There shall be no cross connections between secondary and culinary watersystems.

All wastewater reuse irrigation systems shall be designed and constructed in accordance with the requirements outlined for culinary water systems in SECTIONS 3 and 4 of these specifications. However, all requirements for the treating and reuse of wastewater outlined in the latest applicable Utah Division of Water Quality Standards for Utilization and Isolation of Domestic Wastewater Treatment Works Effluent shall be followed. These requirements include, but are not limited to, a reuse project plan, allowed uses, required treatment processes and water quality limits.

**3.7 OTHER UTILITIES SYSTEMS DESIGN.** All other utility systems shall meet the following:

**3.7.1 RESPONSIBILITY.** Other necessary utility installations (Gas, Electricity, Phone, T.V.) will be coordinated and installed by the developer.

**3.7.2 STREETLIGHTS.** All developments shall include streetlights and necessary appurtenances in accordance with the Cities specifications.

**3.7.3 BURIAL OF LINES.** All utility lines in subdivisions, planned unit developments, and other developments shall be underground. Lines shall be buried at a minimum depth of forty-two (42) inches for primary power. Power lines shall not be buried in any water or sewer trench.

**3.7.4 LAYOUT.** Utility lines shall be located within designated utility easements and in accordance with the requirements of the Technical Review Committee (TRC).

**3.7.5 FRONT LOT LINE SYSTEMS.** Where utilities are in front lot lines, other utility system construction shall not begin until the completion of water, sewer, curb, and gutter, and must be complete before installation of street asphalt.

**3.7.6 QUALITY CONTROL.** All utility trench construction shall conform to the design and testing requirements set forth in Section 4.4 (Pipeline Construction) of these standards.

**3.8 TRAFFIC STANDARDS.** This sub-section sets forth the criteria for access control and Traffic Impact Studies.

**3.8.1 ACCESS CONTROL.** The general access control requirements for arterials and collectors are provided below. All access points on these facilities shall be subject to approval by the city representative or designated representative. Where deemed necessary, stricter requirements may be invoked.

**3.9.1.1. GENERAL REQUIREMENTS.** Direct access to a residential lot(s) shall not be allowed unless otherwise approved by the city representative. If allowed, additional requirements and restrictions may be imposed such as increased setbacks, circular drives, etc.

A. Driveway access shall not be allowed within one hundred fifty feet of the nearest right-of-way line of an intersecting street for major collectors and one hundred eight-five (185) feet for arterials (see section 3.2.4).

B. Unless otherwise approved by city representative, access shall be limited to one driveway for each tract of property separately owned. Properties contiguous to each other and owned by, or previously owned by, the same party are one tract.

C. Driveways giving direct access may be denied if alternate access is available.

D. When necessary for the safe and efficient movement of traffic, access points may be required to be designed for right turns in and out only and will include appropriate deceleration and turning lanes.

E. When approved or directed by the city representative, a driveway access design may be a "street type intersection" with curb returns.

**3.8.2 TRAFFIC IMPACT STUDIES.** A Traffic Impact Study, (TIS) is a specialized study of the impacts that a certain type and size of development will have on the surrounding transportation system. It is specifically concerned with the generation, distribution, and assignment of traffic to and from the new development. The term new development also includes properties that are being redeveloped.

A TIS shall be required for all new developments or additions to existing developments which generate 100 or more trips during the morning or afternoon peak hours, or which will have a significant impact on the City's transportation system as determined by the city representative. Traffic Impact Studies are divided into three categories. The scale of development will determine which category of study will be required. Each category differs by specific analysis requirements for the study and the study's level of detail. Below is a description of each category.

CATEGORY I -- Developments which generate 100 or more new peak hour trips, but less than 500 trips during the morning or afternoon peak hours. Peak hour trips will be determined by referring to ITEs Trip Generation Manual.

In addition to the above threshold requirements, a Category I TIS may also be required by the city representative for any specific traffic problems or concerns such as:

- proposed or existing offset intersections.
- situation with a high number of traffic accidents.
- driveway conflicts with adjacent developments.
- nearby intersections that have reached their capacity.
- proposed property rezones when there is a significant potential increase intratic volumes.

- when the original TIS is more than two years old, or where the proposed traffic volumes in the original TIS increase by more than twenty percent.

For a Category I TIS, the study horizon shall be limited to the opening year of the full build-out of the development.

The minimum study area shall include site access drives, affected signalized intersections and major unsignalized street intersections.

CATEGORY II -- Developments which generate from five hundred to one thousand new peak hour trips during the morning or afternoon peak hours.

The study horizon shall be for the year of completion for each phase of the development, the year of its completion and five years after the development's completion.

The minimum study area shall include the site access drives and all signalized intersections and major unsignalized street intersections within one-half mile of the development.

CATEGORY III -- Developments which generate above one thousand new peak hour trips during the morning or afternoon peak hours.

The study horizon shall be for the year of completion for each phase of the development, the year of its completion, five years after the development's completion, and ten years after the development's completion.

The minimum study area shall include the site access drives and all signalized intersections and major unsignalized street intersections within one-half mile of the development.

The city representative, or his designated representative, shall make the final decision of requiring a TIS and determining whether the study falls within Category I, II, or III.

The TIS shall be conducted and prepared by a qualified Traffic Engineer. The subject Engineer shall have special training and experience in traffic engineering and hold a Professional Traffic Operations Engineer (PTOE) certification as promulgated by the Institute of Transportation Engineers (ITE).

Generally, the data necessary for such a study will require a description of the study area, the scope of development, turning movement traffic counts, accident analyses, roadway geometry, traffic control devices, and trips generated by the new development. The roadways and intersections within the study area shall be analyzed with and without the proposed development to identify projected impacts regarding level of service and safety.

Where the road will operate at Level of Service >C' or better without the development, the traffic impact of the development on the roadways, and intersections within the study area shall be mitigated to Level of Service >C'. Mitigation to Level of Service >D' may be acceptable with the concurrence of the city. A list of mitigation improvements will be provided in the study to achieve this Level of Service.

The guidelines and specific requirements for the preparation of a TIS are found in the Santa Clara City Traffic Impact Study Guidelines. All studies prepared for submittal to the City shall follow these guidelines unless otherwise approved.

**3.9 SURVEY MONUMENTATION STANDARDS.** This sub-section sets forth the general standards for survey monuments.

**3.9.1 GENERAL REQUIREMENTS.** Only a Land Surveyor, registered in the State of Utah, shall be authorized to determine, or establish the exact location for a survey monument. Only such registered Land Surveyor shall be authorized to perpetuate and reference existing Class I and II survey monuments located within the limits of public or private streets.

**3.9.2 MONUMENTS.** Class I or II monuments shall be set in accordance with the recorded maps so that the survey, or any part thereof, may be readily retraced. Such monuments shall be set at:

- A. All angle points in survey boundary (Class II).
- B. All angle points of tangency and points of curvature on and along survey boundary (Class II).
- C. All street centerline intersections Class I).
- D. At a P.I. outside of right-of-way (Class II).  
If the P.I. falls outside the limits of pavement, then P.C.'s and P.T.'s shall be monumented with Class I.  
  
If the P.I. falls inside the pavement area, then a Class I monument is required and no monumentation required for P.C.'s and P.T.'s.
- E. All intersections of street centerlines at survey boundary (Class II).
- F. Six-hundred-foot intervals, unless otherwise approved. If line of sight is not obtainable within a six-hundred-foot interval, then monuments will be required to be closer together unless otherwise approved by the City Surveyor.

All the above established points which fall within the limits of public or private rights-of-way shall be referenced with four permanently established reference points within a radius of twenty (20) feet to one hundred (100) feet all of which shall be outside the pavement area. The angle from tie to tie shall be as near ninety degrees as possible, radiating from the established intersection points.

A copy of the survey notes documenting the setting of the reference ties shall be kept by the responsible surveyor and a copy shall be delivered to the office of the City Surveyor and of the County Surveyor's depository.

When a section corner, quarter corner or sixteenth corner falls within a fully improved roadway and must be set, or reset, the responsible surveyor shall contact the County and City Surveyor for directions and/or requirements.

All monuments shall have brass marker or aluminum cap in accordance with the standard drawings. The surveyor's registration or license number shall be stamped on the cap.

Monuments must be set prior to the final acceptance of the improvements.

Where hard rock or other physical obstructions are encountered, monument length sufficient to resist removal may vary within reasonable limits.

All monuments shall be set in such a manner that the accuracy of their relative positions is not less than second-order Class II, in accordance with the specifications established by the U.S. Federal Geodetic Control Committee. When monuments are being reset, the initial order used in the setting shall be used, but in no event shall it be less than second-order Class II.

**3.9.3 TYPES OF MONUMENTS.** Class I and II monuments shall be installed in accordance with City requirements.

## SECTION 4

### CONSTRUCTION STANDARDS

**4.1 INTRODUCTION.** This section sets forth the requirements for earthwork, pipeline construction, roadway construction, chip seals, slurry seals, concrete work, and restoration of surface improvements.

**4.2 SURVEY REQUIREMENTS.** Prior to commencing the work, all construction shall have appropriate construction staking in conformance with the approved drawings unless otherwise approved by the city representative. The staking shall have all necessary information including, but not limited to, stationing, cut or fill data, off-set distance, and invert elevations. The information shall be placed on the face of stakes in a legible manner using weatherproof marking materials and shall be in accordance with general surveying practice. All construction staking shall be under the direction of the Engineer responsible for the project.

When a water main design has a profile with grades, a grade line will be staked at the designated grades prior to installation of any pipe. A laser may be used in lieu of a grade line. All sewer lines and storm drains will require that a grade line, or laser, be set and checked prior to installation of any pipe.

**4.3 EARTHWORK.** This subsection defines the requirements for excavation and backfill for structures, preparation of embankments and fills, and subgrade preparation for pavement and other surface improvements.

**4.3.1 MATERIALS.** Earthwork materials shall conform to the following:

**4.3.1.1 EXCAVATION.** All structures shall be founded on prepared original soil or engineered fill. Unauthorized excavation below the specified structure subgrade shall be replaced with concrete, untreated base course, or approved engineering fill thoroughly compacted to a minimum of ninety five percent of maximum dry density. Subgrade soil for all concrete structures, regardless of type or location, shall be firm and thoroughly compacted to a minimum of ninety-five (95) percent of maximum dry density for granular soils or ninety (90) percent of maximum dry density for silty/clay (fine-grained) soils, as measured by a modified proctor.

**4.3.1.2 SUBSOIL REINFORCEMENT.** Coarse gravel, crushed stone, or a geotextile may be used for subsoil reinforcement when approved by the city representative. Coarse gravel or crushed stone shall be applied in six (6) inch layers, each layer being embedded in the subsoil by thorough tamping. Approved geotextile shall be installed in accordance with manufacturers recommendations. All excess soil shall be removed. The finished elevation of any subsoil shall not be above the specified sub-grade elevation.

**4.3.1.3 BACKFILL.** Backfill shall be placed to the lines and grades shown on the approved drawings, or as directed by the city's representative. Prior to backfilling any construction work, the excavation shall be cleaned of all forms, trash and debris, and such material shall be removed from the site. Backfill material shall be approved and consist of excavated material or clean imported materials such as sand, gravel, or other suitable material.

Backfill shall be placed in layers compatible with the equipment and not exceeding six (6) inches in compacted thickness. Each layer shall be compacted to a minimum density of ninety-five (95) percent of maximum dry density for granular soils or ninety (90) percent of maximum dry density for silty/clay (fine-grained) soils, as measured by a modified proctor.

**4.3.2 CONSTRUCTION METHODS.** The methods employed in performing the work shall be the responsibility of the Contractor. These methods shall include, but are not limited to, the following:

**4.3.2.1 CONSTRUCTION OF EMBANKMENTS.** Unsuitable materials that occur in the foundations for embankments shall be removed by clearing, stripping and/or grubbing. When required by the city representative, the embankment and the materials used shall be approved by a Geotechnical Engineer. All materials in embankments shall be placed, moisture conditioned, and compacted as outlined in the following paragraphs.

When the material needed for embankment exceeds the amount of material available from excavation, sufficient additional materials shall be provided by the Contractor. All materials used for embankment construction shall be free from deleterious materials and rocks larger than three inches in diameter and all other material unsuitable for construction of embankments. Rocks larger than three inches may be used when recommended by the Geotechnical Engineer and approved by the city representative.

Grading of completed embankments shall bring the surfaces to a smooth, uniform condition with final grades being within 0.1 foot of the design grade. Cut and fill slopes shall be in accordance with the Geotechnical Report recommendation.

**4.3.2.2 COMPACTION OF EARTH MATERIALS.** The fill material shall be deposited in horizontal layers having a thickness of not more than eight (8) inches and then compacted to the density as herein specified. Moisture content during compaction operations shall be within two percent (2%) of optimum for granular soils and shall be two to five above (2%-5) optimum for fine-grained soils unless otherwise directed by the Geotechnical Engineer. The moisture content shall be uniform throughout the layers.

If the moisture content is greater than specified for compaction, the compaction operations shall be delayed until such time as the material has dried to the specified moisture content. When the material has been conditioned as herein specified, the backfill or embankment shall be compacted as directed below.

Under roadways, curb, and gutter, sidewalks, and driveways, and extending 2feet beyond the proposed construction (or to a distance equal to the depth of the embankment material, whichever is greater), the embankment material shall be compacted to a density equal to not less than ninety-five (95) percent for granular soils and ninety (90) percent for fine-grained soils. Other fills and embankments not noted above shall be compacted to ninety (90) percent maximum dry density. When compaction cannot be met with native or imported materials, a sand slurry mix (no gravel) may be used in lieu of compacted materials for backfill which is above the six to eight (6-8) inch zone above the pipe.

Exposed natural soils within construction areas, beneath walkways, slabs and pavement shall be scarified to a depth of six (6) to eight (8) inches, moisture conditioned, and compacted to the specified density. Where rock or other acceptable material is exposed, scarification may not be necessary.

Foundations for structures shall be uniform throughout and shall not be placed partially on undisturbed soil or compacted fill and partially on cemented deposits or rock.

Foundation soils should not be allowed to become saturated during construction.

**4.3.2.3 SUBGRADE PREPARATION.** As a minimum, the original soils under roadways, curb and gutter, sidewalks, and driveways shall be scarified to a depth of six (6) to eight (8) inches prior to compaction operations. All scarified soils shall be compacted to the equivalent of ninety-five (95) percent of maximum dry density for granular soils or ninety (90) percent of maximum dry density for fine grain soils. Additional over excavation and recompacting of original soils due to poor subgrade conditions may be required. Subgrades shall be shaped and graded to the design grade. Drainage shall be always maintained. Subgrades shall be stabilized and compacted as directed. When springs or underground water is encountered during construction the Engineer and the city's representatives shall be notified immediately. Work shall not proceed until an acceptable mitigation plan is approved. Ground water discovered during construction shall not be ignored!

The subgrade preparation requirements listed above are the minimum. When required, the subgrade shall be over excavated and the material removed from the site. Select borrow material



may be imported, placed, and compacted as directed by the city's representative.

To demonstrate the stability and compaction of the subgrade, the Contractor may be required to proof-roll the subgrade prior to placing any base gravel. The subgrade shall be proof rolled with at least one pass coverage with a roller with pneumatic tires or other acceptable equipment of at least ten-ton capacity. All proof-rolling shall be accomplished in the presence of the city's representative. Ground contact pressure for all tires shall be eighty-five to ninety (85-90) psi unless otherwise recommended.

When the proof-rolling shows an area to be unstable, it shall be brought to satisfactory stability by additional compaction, reworking, or removal of unsuitable material and replacement with acceptable material.

**4.3.2.4 CONSTRUCTION OF NON-STRUCTURAL FILLS.** Fills shall be placed to the lines and grades shown on the approved drawings and shall include all areas not specifically designated for support of structures, roads, utilities, easements, drainage ways, etc. (such as landscape areas, open space areas, etc.). Fill material shall generally be compacted to a minimum of ninety (90) percent of maximum density and shall consist of material that can be compacted to prevent settlement such as soil, rocks, blocks, crushed stone, broken concrete, etc. Fill material shall not include broken asphalt, toxic or hazardous materials waste sludge, deleterious materials such as muck, ash, sod, grass, trash, tree stumps, lumber, dead animals, etc.

**4.3.2.5 RETAINING WALLS REQUIRED.** When a difference in grade exists between two adjacent eleven thousand (11,000) square foot or smaller lots a retaining wall shall be required in any new development, a retaining wall shall be constructed subject to the specifications of city code, Chapter 17.28.060 Retaining Walls, Difference in Grade.

- Retaining walls separating properties shall be constructed and accepted prior to recording the Final Subdivision Plat or included in the guarantee posted and bonded for with the city prior to recording the Final Subdivision Plat.
- Retaining walls with heights greater than four (4') feet as measured from the bottom of the footing to the top of the wall shall be designed and inspected by a professional engineer licensed in the State of Utah. A compliance letter must be submitted by the professional engineer to the city upon completion of retaining wall construction prior to final acceptance by the city.

**4.3.3 QUALITY CONTROL.** All earthwork shall be performed in accordance with these standards and shall be tested and accepted as follows:

**4.3.3.1 TESTING.** Minimum testing of earthwork shall be as follows:

Soil Classification - One per material source. Soil classifications shall be in accordance with AASHTO M-145. For determination of granular soils or fine-

grained soils use ASTM D-2487 (Unified Soil Classification System). The sieve analysis shall be according to ASTM C-136 and C-117.

Soil Proctor -

One determination for each significant change in soil type as necessary to provide required compaction testing. Tests shall be ASTM D-1557 method A or D (modified proctor).

Earth fill moisture/  
density  
determination -

One test per five hundred (500) cubic yards of fill placed in an embankment. Tests shall be ASTM D-1556 or D-2922 and D-3017.

Subgrade moisture/  
density  
determination -

One test per seven hundred fifty (750) square yards of surface area. Tests shall be ASTM D-1556 or D-2922 and D-3017. Additional moisture density determinations may be made when required by the City's Representative.

**4.3.3.2 ACCEPTANCE.** Any earthwork determined not to be following these standards shall be removed and replaced or reworked until compliance is obtained. Costs for the rework or testing the rework shall be paid for by the Contractor.

**4.3.4 SPECIAL REQUIREMENTS.** The requirements outlined in this section are only a minimum. When a geotechnical investigation is required, the recommendations of the geotechnical report shall be followed unless said recommendations are less than minimum standards.

All development projects shall submit a final soils engineering and engineering geology report in accordance with Uniform Building Code, 1997 Edition, Appendix Chapter 33, or as subsequently modified.

**4.4 PIPELINE CONSTRUCTION.** This subsection covers the requirements for materials, trenching, placing, backfilling, cleaning, testing and other miscellaneous requirements for underground pipeline construction and associated work. This section incorporates the requirements of the AWWA Standards and the Manufacturer's Recommended Installation Procedures, whichever is more stringent.

**4.4.1 MATERIALS.** This subsection specifies the acceptable materials for pipeline construction for use in sanitary sewers, underground culverts, storm drains, water pipes, and appurtenant construction. All materials shall be new and conform to the requirements for class, brand, size, and material as specified herein. All materials shall be stored and handled in accordance with manufacturers recommendations.

**A. NSF STANDARD FOR HEALTH EFFECTS.** All materials which may contact drinking water, including pipes, gaskets, lubricants, and O-Rings, shall be ANSI-certified as meeting the requirements of NSF Standard 61, Drinking Water System Components - Health Effects. To permit field-verification of this certification, all such components shall be appropriately stamped with the NSF logo.

**B. AWWA STANDARDS FOR MECHANICAL PROPERTIES.** Pipe, joints, fittings, valves, and fire hydrants shall conform to NSF Standard 61 or Standard 14, and applicable sections of ANSI/AWWA Standards C104-A21.4-03 through C550-05 and C900-07 through C950-07.

**4.4.1.1 SEWER PIPE AND FITTINGS.** Only those pipe materials listed below may be used in the construction of sanitary sewer line unless otherwise approved in writing by the city representative.

**A. POLYVINYL CHLORIDE (PVC) PLASTIC SEWER PIPE.** This specification covers rigid polyvinyl chloride (PVC) pipe and fittings. PVC pipe and fittings from four (4) inches to fifteen (15) inches in diameter shall

meet or exceed all the requirements of ASTM D-3034 with a minimum wall thickness to diameter ratio of SDR-35. PVC pipe and fittings from eighteen (18) inches to twenty-seven (27) inches in diameter shall meet or exceed the requirements of ASTM F-679.

Each pipe shall be stamped by the manufacturer indicating compliance with the requirements of the appropriate specification. Any pipe not so stamped shall be rejected.

All pipe and fittings shall be homogeneous throughout and free from cracks, holes, foreign inclusions, or other defects. All PVC pipe and fittings shall be made from clean, virgin, Type 1, Grade 1, Polyvinyl Chloride conforming to ASTM D-1784.

All pipe joints shall be bell and spigot type with flexible elastomeric seals in accordance with ASTM F-477. Pipe and fittings shall be assembled with a non-toxic lubricant. Pipes of four (4) inch diameter may be the solvent weld type, in accordance with ASTM F-656 for primer and ASTM D-2564 for glue. Pipe shall have the following minimum SDR-35 dimensions.

**TABLE 4.1  
SEWER PIPE DIMENSIONS**

Nominal Pipe Size (Inches)	Outside Diameter (Inches)	Minimum Wall Thickness (Inches)
4	4.215	0.125
6	6.275	0.180
8	8.400	0.240
10	10.500	0.300
12	12.500	0.360

Spigot ends shall have a fifteen (15) degree tapered end with a memory mark around the diameter of the pipe to indicate proper insertion depth. Fittings shall be of the same material as the pipe and shall not have a wall thickness less than that of the pipe furnished.

**B. REINFORCED CONCRETE PIPE.** Reinforced concrete pipe may be used for all appropriate applications. For pipe greater than twenty-four inches in diameter, and where any non-reinforced concrete pipe installation does not provide a cover of at least three feet over the top of the pipe, reinforced concrete pipe shall be used. Reinforced concrete pipe shall comply with the requirements of ASTM C-76 (Class II - V) unless otherwise approved by the city representative. Type V cement shall be used unless otherwise approved. Joints shall be of the bell and spigot design with rubber gasket type joints, with an alternate option of tongue and groove joints for storm drain lines when approved by the city representative.

**4.4.1.2 STORM DRAINPIPE.** Pipe listed under Sections 4.4.1.1 A, C, and D. "Sewer Pipes" of these standards, as well as the following pipes, may be used in the construction of storm drain lines and culverts.

**A. CORRUGATED POLYETHYLENE PIPE.** Corrugated polyethylene pipe shall be high density polyethylene corrugated exterior with a smooth interior wall. Eight to ten (8-10) inch diameter shall meet the requirements of AASHTO M-252 and have a smooth interior liner. Twelve to thirty-six (12-36) inch diameters shall conform to AASHTO M-294 Type S. Forty-two to forty-eight (42-48) inch diameter shall conform to AASHTO MP-6 type. Materials shall conform to ASTM D-3350. All pipe joints and fittings shall be watertight and conform to AASHTO M-353 or M-294 and shall be approved by the city's representative.

**4.4.1.3 SEWER MANHOLES.** This subsection covers the requirements for the materials used in sanitary sewer and storm water manholes. Manholes shall be watertight and be furnished complete with cast iron rings and covers as follows:

A. **CONCRETE BASES.** Manhole bases shall be either pre-cast or cast in place. Precast manhole bases shall conform to ASTM C-478. Concrete for cast in place bases shall be in accordance with Section 4.8.1 of these specifications. Type V cement shall be used for precast and cast in place bases.

Where sewer lines pass through or enter manholes, the invert channels shall be smooth and semi-circular in cross-section. Changes of direction of flow within the manholes shall be made with a smooth curve with the longest radius possible. The depth of the channel in the manhole base shall be the full diameter of the sewer pipe being used at that manhole. The floor of the manhole outside the flow channels shall be smooth and slope toward the channel in accordance with standard drawings and not less than one-half (1/2) inch per foot nor more than one (1) inch per foot.

B. **WALL AND CONE SECTIONS.** All manholes shall be constructed of either forty-eight (48) inch or sixty (60) inch inside diameter pre-cast, sectional, reinforced concrete manholes. Both cylindrical and taper sections shall conform to the requirements of ASTM Designation C-478 for precast Reinforced Concrete Manhole Sections. All Manholes shall have ladders in accordance with the standard drawings.

Throat length of manholes shall be adjustable by use of appropriate diameter grade ring sections. The maximum height shall be eighteen (18) inches.

The taper section shall be a maximum of three (3) feet in height, shall be of eccentric conical design, and shall taper uniformly from forty-eight (48) or sixty (60) inches to thirty (30) inches inside diameter. The cone shall be set on the manhole sections, so all ladder rungs are aligned.

When manhole depths are less than four (4) feet manhole cones shall not be used. The manhole shall consist of a cylindrical manhole section with a precast flat manhole top in accordance with ASTM C-478.

Sixty (60) inch inside diameter sewer manholes shall be required for all sewers greater than twelve (12) inches in diameter or deeper than twelve feet, or where three (3) or more eight (8) inch or greater lines converge in the manhole.

The shaft section of the manhole shall be furnished in section lengths of one (1), two (2), three (3), and four (4) feet as required. The least number of sections should be used.

Manholes larger than sixty (60) inch inside diameter may be required when designated by the city representative.

All joint surfaces of pre-cast sections and the face of the manhole base shall be thoroughly cleaned prior to setting the sections. Joints shall be sealed with a minimum one (1) inch thick flexible joint sealant which shall conform to the requirements of ASTM C-923. All joints including any grade rings where joint has not protruded to the interval of the manhole shall be filled with grout prior to final acceptance.

**C. WATER-TIGHTNESS.** All manholes shall be watertight. Any cracks or imperfections shall be satisfactorily repaired. Materials and methods used shall be subject to approval of the city's representative.

**D. IRON CASTINGS.** All iron castings shall conform to the requirements of ASTM A-48 (Class 30) for grey iron castings. Frames and covers shall have a minimum combined weight of four hundred (400) pounds. All castings shall be designed to carry a minimum HS-20 traffic loading.

The cover and ring seat shall be machined so that the entire area of the seat will be in contact with the cover, in any position of the cover on the seat. Frames and covers shall be so constructed and machined that the parts are interchangeable. The tops of the cover and frames shall be flush, and the clearance between the frame and cover shall be one-eighth (1/8) of an inch all around. The top surface of each cover shall be cast with a studded pattern including the word "Sewer" for sanitary application and Storm for storm drain applications. Letters and studs shall be raised three-eighth (3/8) inch. Each cover shall be provided with not less than twelve (12) ventilating holes of three quarter (3/4) inch diameter each.

All manhole frames shall be carefully set to the finished grade or as directed by the city's representative. When set in roadways, walkways or other travel ways, the finished manhole cover, grade, and slope shall be adjusted to match that of the traveled surface. Manhole frames shall be set in place on the manhole throat and shall be sealed with an approved flexible joint sealant which shall conform to the requirements of ASTM C-923. Frames or covers loosened from the manhole throat shall be reset and any frames, covers or throat sections damaged or broken shall be replaced prior to acceptance by the city's representative.

**E. MANHOLE STEPS.** Manhole steps shall be constructed in accordance with ASTM C-478 and the standard drawings.

Manhole steps shall be installed at intervals of twelve (12) inches between

steps. Steps shall be firmly installed into the concrete wall and taper sections of all manholes to a minimum depth of three and three-eighths (3 3/8) inches, as shown in the drawings. Each step shall be solidly anchored to the wall so it will not pull out or break under repeated use. Steps shall be aligned vertically to form a continuous ladder from top to bottom.

**4.4.1.4 WATER PIPE AND FITTINGS.** The materials used for pipe and fittings shall all be new and conform to the requirements for class, brand, size, and material as specified.

A copy of the manufacturer's installation recommendation for each type of pipe shall be provided for each construction job and shall be always available on the jobsite. These recommendations shall be followed during construction unless instructed otherwise by the city's representative. All pipe materials are as outlined below.

A. **GENERAL PIPE REQUIREMENTS.** Pipe materials shall conform to the following requirements.

**TABLE 4.2  
GENERAL PIPE REQUIREMENTS**

SIZE	TYPE
3/4"	Blue Poly (HDPE) Iron Pipe Size
1", 1 1/2", 2"	Blue Poly (HDPE) Iron Pipe Size
Over 2"	Ductile Iron Class 51 with poly jacket sock <u>or</u> PVC C-900, Class 150 (sand bedded) see note #1 below.

**SIZE TYPE**

3/4" to 1" 1

1/2" - 2"

Blue Poly (HDPE) Copper Tube Size

Over 2"

Ductile Iron Class 51 with poly jacket sock

or

PVC C-900, Class 150 (sand bedded) see note #1 below.



Note:

1. High density polyethylene pipe may be used upon approval of the Public Services Department.
2. For pipes greater than 12 inches ductile iron is required.

All pipes shall conform to the current AWWA standards for each class of pipe listed above.

**B. CONNECTING WATER METERS.** Only authorized employees of the Water Department shall be allowed to connect or disconnect water meters. All boxes set in concrete shall be flanged to prevent settlement.

**C. DUCTILE IRON PIPE.** All ductile iron pipe shall be Class 51 conforming to the latest edition of AWWA Specifications C-151 (ANSI A21.51).

**C.1 JOINTS.** Ductile Iron Pipe shall be either Mechanical Joints, Rubber Gasket Slip-on Joints, Flanged Joints, or a combination of the above as specified on the plans. Pipe shall also conform to all current AWWA standards.

**C.2 POLYETHYLENE WRAPPING.** A polyethylene wrap shall be required on all ductile iron pipe. The polyethylene wrap tubing shall be cut to provide for a minimum of one foot of lap over both the adjoining pipes. The ends of the tubing shall be wrapped using three circumferential turns of plastic adhesive tape. The loose wrap on the barrel shall be pulled snugly around the barrel of the pipe and the excess folded over at the top. This fold shall be held in place by means of six-inch-long strips of plastic tape placed at intervals of three feet along the pipe barrel.

Bends, reducers, offsets, and restraint gland locations shall be wrapped in the same manner as the pipe. Valves shall be wrapped by bringing the tube wrap on the adjacent pipe over the bells of the valve and sealing with adhesive tape. The valve bodies shall then be wrapped with flat sheets passed under the valve bottom and brought up around the body to the stem and fastened with the tape.

**D. PVC PIPE.** All PVC Pipe used shall meet the latest AWWA standards C-900 and C-905. HDPE pipe shall meet the latest AWWA standards C-901 and C-906.

**E. PIPE FITTINGS.** (Two inches through 30 inches) flanged and mechanical joint fittings shall be ductile iron class 250 and shall be produced in accordance with ANSI/AWWA C-110/A 21.10 and ANSI/AWWA C-111/A21.11 and shall conform to details and dimensions published therein. Fittings are cement lined and seal coated in accordance with ANSI/AWWA C-104/A21.04.

For large tapping's (6 inch and greater) tapped into PVC or ductile iron pipe, the following tapping sleeves are approved for pressures less than 125 psi:

Romac Style fts 419, fts 420  
Power Seal (5 bolt), model 3480  
Romac 305 Stainless Steel Service Saddle

For pressures greater than 125 psi, a mechanical joint sleeve type will be required. The following are approved for use.

Mueller H-615  
5-149-DI  
Clow F-5205  
Power Seal Model 3490  
Romac SST-III with ductile flange rated at 200 psi  
Ford FTSS

For larger diameter pipe:

FTS-425 Class D  
For HDPE - Romac SST-H

**F. TAPPING MATERIAL SPECIFICATION.** For small tapping's (three quarter (3/4) inch through two (2) inch) tapped into cast iron, steel, PVC, or ductile iron pipe, the following materials shall be required:

**F.1 SADDLE CASTINGS.** Large saddle tapping's shall be stainless steel or bronze single/double strap.

**F.2 STAINLESS STEEL STRAP.** The stainless-steel strap shall consist of a two (2) inch wide strap and shall come complete with sufficient stainless steel or bronze bolts, nuts, and washers (with five-eighths [5/8] inch N.C. Teflon coated roll threads) to properly clamp the strap to the pipe. M.I.G. welds shall be passivated for resistance to corrosion.

F.3 **GASKETS.** Gaskets shall be made from virgin SBR compounded for water services.

G. **VALVES AND BOXES.** Unless otherwise specified by the Public Services Department, all valves, ten (10) inches and smaller, shall be of a resilient-seat-gate-valve type, and all valves over ten (10) inches ; except for a ten (10) inch hot tap.

G.1 **GATE AND BUTTERFLY VALVES.** Valves shall conform to the latest revision of AWWA valve standards.

All valves, ten (10) inches and less, installed next to a fitting must be flange x mechanical joint (MJ) and installed with the flange end connecting to the tee, cross, or fitting and megaluged to the line unless otherwise approved by the Public Works Department. Valves greater than twelve inches shall have flange x flange with an MJ adaptor to flange to tee, cross, or fitting and shall be megaluged to line.

All six- and eight-inch valves shall have a 16"x 16"x 4" slab of concrete placed under them for support. Valves ten inches and greater shall have a 20"x 20"x 4" concrete slab placed under them for support. All support slabs shall be tied to the valves.

All setter shut off valves shall be provided with bronze handles.

G.2 **VALVE BOXES.** All valves shall be provided with a cast iron valve box of the extension sleeve type or a screw type adjustable, and the height shall be adjusted to bring the top of the valve box flush with the finished surface. Extension sleeve shall be drilled or slotted, and the marking wire shall be threaded through. The valve box shall not be less than five inches in diameter and shall have a minimum wall thickness of .375 inch. The box shall be provided with a suitable base and cover. The word "WATER" shall be cast on the cover. Valve boxes intended for irrigation main line valves shall be triangle in shape and the word "Irrigation" shall be cast on the cover.

Valve boxes shall be installed plumb and properly positioned to allow access of the operating wrench. To ensure that the box is not displaced during backfill operations, the backfill shall be hand mechanically

tamped for five feet each way along the trench. All valveboxes shall include a concrete collar in accordance with the standard drawings with flow indication arrows.

**H. WATER SERVICE LATERALS.** The material used for water service connections shall comply with the following requirements.

**H.1 SERVICE PIPE.** Service pipe shall be IPS (HDPE)

H.2

Note: No instatite fittings shall be used. If a service lateral becomes damaged during construction of needs to be extended, a new lateral must be installed from the main line to the meter setter. No joints will be allowed. "Crimping" of service line is not allowed. A system shutdown will need to be scheduled for repairs.

**H.3 CORPORATION STOPS.** Corporation stops shall be as manufactured by the Mueller Company, or Ford or approval equal, and shall conform to the several designations shown below for the varioussizes.

**TABLE 4.3  
CORPORATION STOPS**

	WATER SERVICE CONNECTION SIZE			
	3/4"	1"	1-1/2"	2"
MUELLER CO.	H-1500	H-1500	H-1510	H-1501
FORD	F600	F600	F6125	F6125

All services shall be a compression type joint for the service pipe and shall be threaded on the inlet end with an AWWA corporation stop thread.

**H.4 METER SETTER YOKES.** Meter setters or meter yokes shall have a built-in backflow prevention device and shall have a corrosion- resistant bronze body, dual acetyl plastic valves with natural rubber gaskets that are independently acting and capable of giving two levelsof protection; stainless steel springs; a resilient O-ring end-tap seal; andfull port inlet angle ball valve with brass handle. All internal parts shall be accessible without removing the valve from the line. Meters shall be ~~set~~ by Public Works personnel only.

**H.5 METER BOX AND LID.** The meter boxes shall be high density polyethylene (HDPE) Brooks design or equal. Size shall be as follows unless otherwise approved by the city's representative. Meter boxes located in driveways must be traffic rated.

**TABLE 4.4  
METER BOX AND LID SIZE**

PIPE SIZE	METER BOX SIZE
3/4"	17" x 11 3/4" #1419-18
1"	25" x 16" #1324-18
1 2" - 2"	32" x 19" #1730-18

Lid marking shall be approved by the Public Works Department. A concrete collar shall be installed around the meter box in accordance with standard drawings.

All meter boxes shall be placed behind sidewalks in accordance with standard drawings unless otherwise directed by city's representative.

Any meter box covered, or damaged, during construction operations shall be uncovered, replaced, and raised to finish grade by the Contractor. In areas without sidewalks, meter boxes shall be flush, or one inch above the finish grade.

**H.6 SERVICE CONNECTIONS.**

Individual water services shall be three quarter (3/4) inch single service from the water main to the meter setter for normal domestic service. Services shall have a minimum of three (3) feet of cover and be constructed as shown in the standard drawings. For service laterals two inches in diameter and smaller, service saddles shall not be closer than twelve inches (12) from the end of the main, nor closer than eighteen (18) inches to any other service saddle or pipe joint. A mechanical joint type tapping sleeve shall be used on all hot taps where the line pressure is greater than one hundred twenty-five (125) psi. The approved mechanical joint sleeves and type shall be as shown in the standard drawings.

**I. MARKING WIRE.** Marking wire shall be installed on all waterline installations unless otherwise approved by the Public Works Department. Marking wire shall conform to the following:

I.1 Marking wire shall be spliced together with grease nuts, or equal. Prior to installation of the wire nut, a minimum amount of wire shall be bared and twisted together with pliers to assure good contact.

I.2 Marking wire should be taped and pulled tight along the top of the pipe to ensure against breakage.

I.3 Marking wire shall extend up to all hydrants, valves and meter boxes following service lines into meter box. At valve clusters marking wire shall be run to all valves. The wire should be looped, not pig tailed.

I.4 Marking wire shall extend out of the valve box four (4) to six (6) inches.

I.5 It is the Contractor's responsibility to guarantee and show that the marking wire performs satisfactorily for its intended use. It is recommended that the contractor test the performance of the wire prior to installation of surface improvements.

I.6 After all the boxes are raised the Contractor shall notify the Public Works Department to perform the final acceptance testing.

**J. FIRE HYDRANTS.** Fire hydrants shall be a three-nozzle, five and one-half inch (5) diameter Mueller, Modern Centurion, Model A-423; Kennedy, Model K-81A; or approved equal, with foot valve and six (6) inch mechanical joint connection. Fire hydrants shall conform to the latest edition of AWWA C-502, "Dry Barrel Fire Hydrants." All hydrants shall be designed for a working pressure of two hundred (200) psi and a hydrostatic pressure of three hundred fifty (350) psi. Hydrants shall be furnished with a paint finish above the ground line identical in color to the existing hydrant paint (red).

Hydrants shall be installed with a shut-off valve at the mainline. If the hydrant lateral is greater than two hundred (200) feet long, a second valve shall be installed at a location determined by the Public Works Department.

After the hydrant is installed and accepted, it will be the responsibility of the Public Works Department to maintain the hydrant. Where applicable, the customer/property owner will allow the Public Works Department access for said maintenance.

Dead-end mains shall not be installed without prior approval of the Public Works Department. If installed, they shall not exceed six hundred (600) feet in length. Hydrants shall be located at the end of dead-end mains for flushing purposes as well as for fire protection. Washout valves, in lieu of fire hydrants, are not allowed without prior approval of the Public Works Department.

Hydrants shall be of a flanged joint type or mechanical joint inlet. All hydrants shall be so designed as to allow the flanges at sidewalk level to separate without material damage to the main barrel section when struck

by a large object, such as a vehicle. Upon such damage, the main gate valve must remain closed to avoid flooding or washout. Hydrants with a nominal five-inch valve opening shall be furnished with two nominal two and one half (2 ½) inch National Standard Thread Hose Nozzles and one nominal four and one half (4 ½) inch National Standard Thread Pumper Nozzle. All nozzles shall be furnished with a cap and gasket with attaching chain. All hydrants shall open counterclockwise with a pentagon operating nut conforming in size to the specifications of the Public Works Department.

Fire hydrants shall be set to provide at least the minimum pipe cover for the branch supply line. Nozzles shall be at least eighteen (18) inches above finish grade. Each hydrant shall be set on a concrete foundation at least eighteen (18) inches square and four (4) inches thick. Each hydrant shall be blocked against the end of the trench with concrete. Hydrant drainage shall be provided by installing gravel or crushed rock (¾" to 2" washed gravel) around the hydrant, and below the top of the hydrant supply line. One third (1/3) cubic yard of one and one half (1 ½) inch gravel shall be placed around the drain holes just above the hydrant valve casing. All hydrants shall stand plumb. The hydrant pumper nozzles shall face the street and be perpendicular to the curb line. The hose nozzle shall be parallel to the street. Hydrants shall be located inside the street utility easements or as otherwise directed by the Public Works Department.

**K. FLOWABLE BACKFILL.** Flowable backfill material for water main trenches shall be sand slurry in accordance with Section 4.4.2.6(D).

**L. PRESSURE REDUCING VALVES.** Pressure reducing valve installation will be constructed as per the detail shown in the standard drawings. The valves will be as manufactured by Singer and approved by the city representative.

**M. MEGALUG SYSTEM.** A mega lug retainer gland system shall be used on all mechanical joints and shall meet UNI-B-13 for PVC and be UL/FM approved through twelve (12) inch diameter for both ductile iron and PVC pipe.

A mega lug retainer gland system shall be used on all mechanical joints and shall meet Uni-B-13 for PVC and be UL/FM approved through twelve (12) inch diameter for both ductile iron and PVC pipe. The restraint mechanism shall consist of individually activated gripping surfaces to maximize restraint capability. Twist-off nuts, sized the same as the tee-head bolts, shall be used to ensure proper activating of restraining devices. The gland shall be manufactured of ductile iron conforming to ASTM A-536-80. The retainer-gland shall have a pressure rating equal to that of the pipe on which it is used (through fourteen inches) with a minimum safety factor of 2:1. Gland

shall be Mega lug by EBAA Iron, Inc. or approved equal. The type and model of retainer and amount for each connector is shown on standard drawings.

As an alternate to the mega lug system, Ford Uniflange Series 1400 retainer glands and Series 1300 and 1390 joint restraints will be used. For PVC, Ford Uniflange Service 1500 retainer gland will be used. These materials listed are approved for use on the Santa Clara City Water System.

Thrust blocks shall only be placed to accommodate connection to existing facilities and only when deemed necessary by the engineer and agreed to by the city.

**4.4.2 CONSTRUCTION METHODS.** This subsection covers the requirements for trenching, placing, and back filling of all underground pipelines (sewer, water, storm drains, etc.). The methods employed in performing the work shall be the responsibility of the Contractor. The Contractor shall make such changes in the methods used as are necessary to install an acceptable finished product. The methods shall include, but are not limited to the following:

**4.4.2.1 CONTROL OF GROUND WATER.** All trenches shall be kept free from water during excavation, fine grading, pipe laying, jointing, and embedding operations. Where the trench bottom is mucky or otherwise unstable because of the presence of ground water, and in cases where the static ground water elevation is above the bottom of any trench or bell hole excavation, such ground water shall be lowered and controlled to the extent necessary to keep the trench free from water and the trench bottom stable when the work within the trench is in progress. Surface water shall be prevented from entering the trenches.

Dewatering for pipeline construction shall commence when groundwater is first encountered and shall continue until such time as water can be allowed to rise. Requirements of section 4.3.2.2 shall be complied with when groundwater is encountered. Dewatering shall be conducted such that no pipelines are placed in water, nor shall water be allowed to rise over the pipe until the pipeline has been pressure tested and any concrete or mortar has achieved final set. Water shall not be allowed to rise in pipeline trenches or drained excavations until pipelines are backfilled or restrained to prevent flotation.

**EXCAVATION FOR PIPELINES.** Trench excavation shall include all operations necessary for excavation of all materials of whatever nature in relation to pipeline installation. All excavation, including the manner of support and provisions for access to trenches, shall comply with all current regulations as determined by OSHA. Trenches shall be excavated to the lines and grades shown on the drawings, and to a depth to provide the minimum required cover of three (3) feet over the pipe unless otherwise approved by the Public Works Department. Pipe installation shall be in accordance with the pipe manufacturer's recommendations. The



bottom two feet of the trench should have vertical walls. All finish grading necessary for preparation of the trench bottom shall be made manually. Over-excavating shall not be allowed without re-compaction of backfill in accordance with these standards.

Excavation for trenches in rock shall extend to a depth of at least four inches below the bottom of the pipe. Bedding material as outlined in Table 4.1 shall be placed and mechanically compacted to ninety-five (95) percent of maximum dry density in maximum six-inch lifts to provide a smooth, well compacted, and stable foundation for the pipe or appurtenant works.

If gravel is to be used as a backfill material, it must be installed with an approved filter fabric to prevent fine material from migrating into the gravel.

Where unstable earth, mud or muck is encountered in the excavation at the grade of the pipe, the unsuitable material shall be removed to a minimum of twelve inches below grade and the subsequent hole shall be backfilled with crushed rock or gravel (as called out in Table 4.5 under "foundation material") to provide a stable subgrade. The gravel material shall be deposited over the entire trench width. The maximum layer thickness shall be six inches. Each layer shall be compacted by tamping, rolling, vibrating, spading, slicing, rodding or by a combination of one or more of these methods. In addition, the material shall be graded to produce a uniform and continuous support for the entire length of the installed pipe.

Should the Contractor elect to install the pipe by boring, or jacking, approval must first be obtained from the city's representative. The Contractor shall furnish, place, and maintain all supports and shoring that may be required for the sides of the excavation, and all pumping, ditching, or other approved measures for the removal or exclusion of water, including, but not limited to, storm water and wastewater reaching the worksite from any source to prevent damage to the work or adjoining property.

The maximum amount of open trench permitted in any one location shall be two hundred (200) feet, or the length necessary to accommodate the amount of pipe installed in a single day, unless otherwise approved by the city's representative. Open trenches shall not be allowed to stay open without proper safety precautions and barricading by the contractor. Trenches should not be left open overnight.

In the event "foundation material" is used in backfill, or replacement of over excavated material, the Contractor shall, construct dams within the drain rock bedding material at maximum intervals of two hundred (200) feet. The dams shall be constructed to the top of the pipe or the level of groundwater, whichever is greater, with Class "B" Portland Cement Concrete or other approved material and shall have a minimum thickness of six inches.

SIEVE SIZE	FOUNDATION MATERIAL	BEDDING/PIPE ZONE MATERIAL*	FINAL BACKFILL MATERIAL
12"	--	--	Native material which contains no sod, vegetation, rocks larger than 12" diameter, asphalt, or concrete chunks, etc.
6"	--	--	
3"	100	--	
2"	90 - 100	--	
1"	70 - 90	100	
3/4"	--	100	
1/2"	51 - 75	90 - 100	
#4	31 - 65	50 - 80	
#200	2 - 15	9 - 25	

- \* 3/4" clean crushed gravel may be used in lieu of the above table.
- \* For trenches greater than 10' deep a 3/4" clean crushed gravel is used. The gravel should be placed in 12" lifts and compacted by vibration using a concrete vibrator or plate compacter.

**4.4.2.2 SHEETING, BRACING, AND SHORING OF EXCAVATIONS.** All excavations shall be sheeted, braced, and shored as required to protect the workers and existing utilities and improvements from sliding, sloughing, settling or other movement of the trench walls while the work is in progress. All such sheeting, bracing, and shoring shall comply with the requirements of the Utah State Industrial Commission. All damage resulting from lack of adequate sheeting, bracing, and shoring shall be the sole responsibility of the Contractor, and the Contractor shall affect all necessary repairs or reconstruction resulting from such damage.

**4.4.2.3 PIPE LAYING AND BEDDING.** Pipe will be carefully inspected in the field by the Contractor and the city's representative before and after laying. If any cause for rejection is discovered in a pipe before or after it has been laid, it shall be removed and replaced by the Contractor.

When connections are to be made to any existing pipe, conduit, or other appurtenances, the actual elevation or position of which cannot be determined without excavation, the Contractor shall excavate for, and expose the existing improvement before laying any pipe or conduit. The city's representative shall be given the opportunity to inspect the existing pipe or conduit before the connection is made. Adjustments in line or grade of the connecting pipe which may be necessary to accomplish the intent of the plans will be made at this time.

Pipe shall be laid up grade with the socket bell, or collar ends of the pipe upgrade unless otherwise authorized by the city's representative. In general cases, the pipe will be laid in one direction only.

Pipe shall be laid true to line and grade, with uniform bearing under the full length of the barrel of the pipe. Suitable excavation shall be made to receive the bell or collar, which shall not bear upon the subgrade or bedding. Any pipe which is not true to alignment or shows any settlement after laying, shall be removed, and re-laid to the proper grade and alignment.

**A. REQUIREMENTS FOR LINE AND GRADE.** All sewer and drainage pipe shall be installed to the defined line and grade within the following limits.

A.1 Variance from established grade shall be not greater than one - tenth (1/10) of a foot between manholes. Variance from established line shall be not more than one half foot between manholes. Any variances approved shall not impact the system design capacity and shall be approved by the city's representative. Any variations shall not result in a level or reverse slope installation.

A.2 The invert elevations of each manhole and box at the inlet and outlet and distance between manholes and/or boxes shall be accurately verified by use of surveying instruments prior to pouring the floor.

A.3 On main lines, invert elevations of each manhole inlet and outlet and the distance measurements between manholes shall be verified by use of surveying instruments or laser prior to installing precast manhole bases. For service laterals, grades may be verified by use of a carpenter's level or surveying instrument.

A.4 All sewer and drainage pipe systems shall be visually inspected for defects, displacement, proper workmanship, alignment, and general compliance.

**B. INSTALLATION OF PIPE.** A groove shall be excavated along the bottom of the trench to receive the pipe. Bell holes shall be excavated so that only the barrel of the pipe receives bearing from the trench bottom. Large rocks (over three inches in least dimension) near the trench bottom

shall be removed and the hole refilled with approved backfill in accordance with Table 4.15

Water pipe shall not be deflected at the joint more than a maximum of three degrees, per joint, or as per the manufacturer's recommendation.

Sewer and drainpipe shall be laid up grade. All pipe installation shall proceed with joints closely and accurately fitted. Gaskets shall be fitted properly in place and care shall be taken in joining the pipes to avoid twisting the gaskets. Joints shall be clean and dry and a joint lubricant, as recommended by the pipe supplier, shall be applied uniformly to the mating joint surfaces to facilitate easy and positive joint closures. If adjustments to the position of a pipe length are required after being laid, the pipe shall be removed and rejoined as a new pipe. When pipe laying is not in progress, the ends of the pipe shall be closed with a tight-fitting stopper to prevent the entrance of foreign material. In addition to the above requirements, all pipe installation shall comply with the specific requirements of the pipe manufacturer.

**C. SETTING OF BENDS, TEES, CROSSES, AND REDUCERS.** Bends, tees, crosses, and reducers shall be lowered into the trench, inspected, cleaned, and joined to the pipe.

If a megalug retainer system cannot be used, a concrete thrust block system can be substituted, if approved by the Public Works Department, on a case-by-case basis.

**D. PLUGGING OF DEAD-ENDS.** Standard plugs shall be inserted into the bells of all dead-end fittings. Spigot ends of fittings and plain ends of pipe shall be capped. When directed by the city's representative, a concrete reaction or thrust block shall be provided at all plugged outlet fittings in the sizes indicated on the standard drawings or as directed by the city's

representative. The plugs and caps shall also be tied to the pipe with restraining joints. The number and size of rods shall be as specified.

E. **SERVICE LINES.** All service lines shall be installed in accordance with the details shown on the standard drawings.

F. **PIPE TO BE KEPT CLEAN.** All dirt and foreign matter shall be removed from the interior of the pipe before lowering into position in the trench. Pipe shall be kept clean by means approved by the city's representative during and after laying.

G. **JOINTING PIPE SECTIONS.** The sealing surface of the pipe, the bell to be joined, and the elastomeric gaskets shall be cleaned immediately prior to assembly, and assembly shall be made as recommended by the manufacturer. When pipe laying is not in progress, the open ends of installed pipe shall be closed to prevent entrance of trench water into the line. Whenever water is excluded from the interior of the pipe, enough backfill shall be placed on the pipe to prevent floating. Any pipe that has floated shall be removed from the trench and the bedding restored. No pipe shall be laid when the trench or weather conditions are unsuitable for proper installations as determined by the city's representative.

H. **CUTTING PIPE.** The pipe shall be cut in a neat manner without damage to produce a smooth end at right angles to the axis of the pipe. Existing transit AC pipe shall not be cut and should be removed and replaced with ductile or PVC pipe.

I. **END PREPARATION.** Pipe ends shall be cut square, deburred, and beveled in accordance with the pipe manufacturer's recommendations.

J. **PUSH-ON JOINTS.** The push-on joint shall be a single elastomeric gasketed joint which shall be assembled by positioning the elastomeric gasket in the annular groove of the bell and inserting the spigot end of the pipe into the bell. The spigot end of the pipe shall compress the gasket radially to form a positive seal. The gasket and annular groove shall be designed, sized, and shaped so that the gasket will resist displacement. Care shall be taken so that only the correct elastomeric gasket, compatible with the annular groove of the bell, is used. Insertion of the elastomeric gasket in the annular groove of the bell must be in accordance with the manufacturer's recommendations.

K. **MECHANICAL JOINTS.** The mechanical joint shall be a bolted joint of the stuffing box type, and installation recommendations from the manufacturer shall be followed. Each joint shall consist of:

K.1 A bell provided with an exterior gland having bolt holes or slots and a socket with an annular recess for the sealing gasket and the spigot end of the pipe. On all slotted holes the bolts will be supplied with

square shoulders.

K.2 A sealing gasket.

K.3 A follower gland with bolt holes matching those in the fitting.

K.4 Tee bolts and hexagonal nuts of corten metal.

**L. PIPE BEDDING.** Pipe shall be protected from lateral displacement and possible damage resulting from impact or unbalanced loading during backfilling operations by being adequately bedded in accordance with the bedding details in the standard drawings.

Pipe bedding materials shall be deposited and compacted in layers not to exceed six (6) inches in compacted thickness. Deposition and compaction of bedding materials shall be completed simultaneously and uniformly on both sides of the pipe. Compaction shall be accomplished with hand or mechanical compactors to the satisfaction of the city's representative. All bedding materials shall be placed in the trench with hand tools, or other approved methods in such a manner that the bedding materials will be scattered alongside the pipe and not dropped into the trench in compact masses. Bedding materials shall conform to the requirements of Table 4.5 of these standards and shall be free from roots, sod, vegetation, or other deleterious material.

In the event trench materials are not satisfactory for pipe bedding, imported bedding will be required. Imported bedding material shall be graded in accordance with Table 4.5, under "bedding material".

**M. METER BOXES.** All meter boxes shall be located behind the sidewalk. All meters will be provided with concrete collars. Any meter box damaged or covered during the construction operations shall be replaced and/or uncovered and raised to finish grade by the Contractor as determined by the city representative.

**4.4.2.4 BACKFILLING AND COMPACTION.** Backfill shall include filling of all trenches to the original ground surface or final grading elevation as shown on the drawings, or otherwise directed by the city's representative. Backfill shall be carefully placed around and over pipes and shall not be permitted to fall directly on a pipe from such a height, or in such a manner as to cause damage. Backfill material shall be as required by Table 4.5 or as approved by the city's representative and shall not contain any wood, grass, roots, broken concrete, frozen soil, asphalt chunks, trash or debris of any kind that may cause unequal settlement or improper consolidation.

The backfill in all utility trenches under proposed or existing roadways, curb and gutter, sidewalks and driveways shall be compacted to the equivalent of ninety-five (95) percent of maximum dry density for granular soils or ninety

(90) percent of maximum dry density for silty/clay soils unless directed by Geotechnical Report. In shoulders and other street right-of-way areas, the in-place density shall be a minimum of ninety percent of the maximum dry density.

**A. INITIAL BACKFILL PROCEDURE.** (Pipe Zone) Backfill of selected material, which shall conform to the requirements of Table 4.5, shall be placed carefully in eight-inch non-compacted horizontal layers and compacted to a depth of twelve inches over the top of the pipe. During compaction of the initial backfill, special care shall be taken to not move the pipe, either vertically or horizontally. All backfill operations shall be performed in such a manner to avoid any damage to the pipe, valves, laterals, etc. In the event such damage or displacement occurs, such damaged or displaced pipe shall be removed and replaced with undamaged pipe on proper grade and alignment.

**B. FINAL BACKFILL PROCEDURE.** The backfill above a point twelve (12) inches above the top of the pipe shall be filled in horizontal layers twelve (12) inches thick or less with materials free from roots, vegetation or other deleterious material, or rocks, stones, or boulders larger than three inches in the greatest dimension. The material shall be mechanically compacted with appropriate vibrating compaction equipment. Wherever, in the opinion of the city representative, surface settlement is not, critical compaction may be reduced to a minimum of ninety (90) percent of maximum dry density and the backfill shall be neatly rounded over the trench to a sufficient height to allow for settlement to grade after consolidation.

**C. MECHANICAL COMPACTION OF BACKFILL.** The backfill shall be thoroughly compacted by mechanical compaction.

Structural and trench backfill shall be deposited in horizontal layers and compacted by the following method in such manner that the compacted material will be homogeneous and free from lenses, pockets, streaks, and other imperfections.

The materials shall be deposited in horizontal layers across the length or width of the excavation of not more than six inches compacted thickness. The excavation and placing operations shall be such that the materials when compacted will be blended sufficiently to secure the best degree of compaction, impermeability, and stability.

Prior to and during compaction operations, all backfill material shall have the required moisture content and shall be uniform throughout each layer.

If the moisture content is not optimum for compaction, the compaction operations shall be delayed until such time that the material has been brought to the required moisture content. When the material has been properly conditioned, it shall be compacted by using appropriate mechanical compaction equipment as indicated below or as otherwise

approved by the city's representative.

C.1 Vibrating rollers shall consist of a self-propelled roller with a vibrating steel drum of at least one ton capacity. The roller shall have an effective rolling width of at least twenty-four (24) inches and shall deliver a compaction force of at least seven hundred (700) pounds per square inch when vibrating.

C.2 Pneumatic rollers shall consist of a self-propelled roller with pneumatic tires arranged in a manner to provide a satisfactory compacting unit. The roller shall have an effective rolling width of at least thirty (30) inches and shall give a compaction force of at least five hundred (500) pounds per inch of width of tread when fully loaded. The tires shall be uniformly inflated.

C.3 Vibrating plates shall consist of a pneumatic vibrating plate attached to the boom of a backhoe and capable of compacting an area of at least three-square feet. The plate and backhoe combination shall together be capable of exerting a compactive force of at least one thousand (1,000) pounds per square inch.

C.4 Hand compactors shall be used when hand-compacted methods are specified or required because the location of the area to be compacted does not permit the use of self-propelled mechanical compactors. Vibrating plates, "pogo-stick" tampers or other approved hand-compacting equipment shall be used.

C.5 Jetting and flooding or other water consolidation methods are not permitted.

**D. FLOWABLE BACKFILLING.** For trenches under pavement, sidewalk, curb, and gutter, and in all existing city streets, flowable backfill may be used (unless otherwise directed by the city's representative) for backfill and shall be in conformance with the standards for "Flowable Fill" as described below. Flowable fill shall not be used as backfill for water main trenches without prior approval of the city's representative. Flowable fill shall be discharged from the ready-mix truck by reasonable means into the trench to be filled. The fill shall be brought to an elevation equal to the bottom of the road base and shall be finished level to provide a uniform surface. Flowable fill shall not take the place of road base or asphalt in the roadway section.

When surface restoration cannot take place promptly in existing city streets or in other areas where safety is a concern, the flowable fill may be extended to the bottom of the surface course and a temporary driving surface installed. When the permanent surface is installed the temporary surface and flowable fill shall be removed to the level of the bottom of the road base and the roadway structure properly restored in accordance with



these standards.

Flowable fill:

D.1 Portland Cement - Type II or V.

D.2 Fly Ash - ASTM C-618, Class F, except loss on ignition shall not exceed three (3) percent maximum and shall come from a source approved by the city representative.

D.3 The coarse and fine aggregate for flowable fill shall be natural material and consisting of mineral aggregate particles meeting the following requirements.

<u>Sieve Size</u>	<u>Percent Passing</u>
3/4	100
200	0-10

D.4 Mix Design - shall meet the following:

Minimum compressive strength (28 days)	50 PSI
Maximum compressive strength (28 days)	150 PSI
Maximum fly ash per cubic yard	100 lb.
Minimum cement per cubic yard	50 lb.
Minimum Slump	6 in.
Maximum slump	10 in.

**4.4.2.5 TRENCHES ON HIGHWAYS AND STREETS.** No work of any kind shall be performed in any public right-of-way without first obtaining an excavation permit. Wherever any trenches will be in or must cross any State Road or any city road, alley or drainage way, the Contractor, or other responsible party, shall obtain all excavation and encroachment permits as are required for these crossings and shall become familiar with and abide by the rules and regulations of the Utah Department of Transportation and the City of Santa Clara.

All Contractors or responsible parties excavating or encroaching over or under any public right-of-way including roads, drainage way, easements or other public property shall first obtain a permit in compliance with the applicable local ordinances prior to excavating.

All asphalt cuts shall be made with a diamond or carbide-tipped masonry or asphalt cutting saw unless otherwise approved by the city's representative. No scarifier-tooth cuts, back-hoe or bucket rips will be allowed.

All backfilled trenches in roadways shall be patched with hot-mix asphalt within five days of initial excavation, unless otherwise directed by the city's representative. All backfill shall be in accordance with these standards.

All concrete or asphalt surfaces damaged or cut in trenching operations or other work within the right-of-way shall be restored to an as good or better condition in accordance with the provisions outlined in Section 4.7 of these standards.

During the entire trenching, backfilling and patching operations, the Contractor shall be required to observe all safety and traffic control procedures as outlined in these standards.

The Developer and/or Contractor shall be responsible for maintenance of the trench, patch, and related work for a period of twelve (12) months from date of completion.

No more than two hundred (200) feet of trench shall be left unfilled at any time in one continuous run, unless otherwise approved by the City's Representative.

All streets and roads shall be kept free from dust and shall be open to through traffic. Approval to close the street must be obtained by the Contractor from the city representative or his designated representative. At least one-half (1/2) the width of any street or road shall be temporarily restored for use before excavation is commenced on the remaining portion of the street or road.

All excavation, backfilling, and temporary resurfacing on any portion of any street or road shall be completed in one working day so that trenches are not left open or uncovered overnight.

All requirements governing work within a right-of-way as contained in Section 2.5 (Barricades and Warning Signs - Work Area Protection) of these standards shall be adhered to.

All utility installations, i.e., gas, power, phone, cable T.V. and associated utilities, shall conform to the applicable test requirements contained within these standards for earthwork, compaction, base course, bituminous surface course, concrete, and other materials.

**4.4.2.6 CLEANING OF SANITARY SEWER LINES.** When sewer lines have been placed and the trench backfilled, the sewer lines shall be thoroughly cleaned, flushed, and tested with a camera at contractor's cost prior to acceptance by the city's representative. No debris shall be permitted to enter any sewer lines in service. All debris shall be removed from the sewer line and manholes. Methods of cleaning are subject to approval by the city's representative.

**CLEANING AND DISINFECTION OF WATER SYSTEMS.** After being tested and prior to being placed in service, all lines shall be disinfected by chlorination. Prior to chlorination the entire line shall be flushed to ensure that all dirt or foreign objects have been removed from the line. Sufficient chlorine

shall be added to ensure a residual of twenty-five (25) parts per million in the water after twenty-four (24) hours standing in the pipe. Chlorine calcium hypochlorite dry chlorinating chemical solution may be used for this purpose. Methods of application shall be approved by the Public Works Department. Following chlorination, all treated water shall be drained, and the pipeline thoroughly flushed with clean water.

All lines being disinfected shall be flushed after the specified twenty-four (24) hour contact period. Such flushing shall be continued until the water is free from excess chlorine. All lines being disinfected including hydrant laterals, branch lines, and dead-end mains shall be flushed. After final flushing the chlorine residual shall be tested by the Public Works Department. It is the contractor's responsibility to coordinate this test. The discharge of flushed water shall not cause erosion or damage to streets or other property. Procedures for discharge will be subject to the review and approval of the city's representative and Public Works Department.

#### **4.4.2.7 SPECIAL REQUIREMENTS.**

**A. CONNECTIONS TO EXISTING FACILITIES - DRY TAPS.** All connections to existing facilities shall be approved by the City Public Works Department. The Contractor shall make the approved connections to existing facilities as shown on the drawings. Dry connections to existing facilities shall be made only at locations shown on the drawings and shall be made at such times which will cause the least inconvenience to the water user(s). Dry connections shall be planned to minimize the duration of any shut down. The Contractor shall notify the Public Works Department at least two business days prior to beginning any connections to the existing facilities. When a connection to an existing water main is made, approximately four ounces of high-test calcium hypochlorite (HTH) shall be placed in the pipe at each point where the existing main is cut. All new pipe and fittings at such connections shall be swabbed internally with an approved chlorine solution. All connections shall be made in the presence of the Public Works Department representative.

Valves shall not be operated without a Public Works Department representative present. Existing facilities shall not be shut down for connections to new facilities without prior Public Works Department approval. In no case shall an existing pipeline be shut down for a total of more than twenty-four (24) hours (a maximum of three (3), eight-hour periods).

The actual work plan and schedule for making a connection to an existing facility which requires an existing pipeline to be shut down, shall be submitted to the Public Works Department, and shall be approved before the Contractor will be allowed to proceed. The Contractor shall notify, by a method approved by the Public Works Department, all affected Public Works Department customers at least twenty-four hours prior to shut

down. Valves at connections to all existing facilities shall be operated by the Contractor, but only in the presence of the Public Works Department representative. If the water will be shut off for an extended period, the Public Works Department may require the Contractor to supply water for the Public Works Department's customers.

**B. CONNECTION TO EXISTING FACILITIES - WET TAPS** No wet taps shall be made without prior approval. Prior to tapping the main, the tapping valve and fittings shall be properly installed, and pressure tested and approved by the Public Works Department. The Contractor shall also provide all necessary equipment, labor, and appurtenances necessary to complete the job.

**4.4.3 QUALITY CONTROL.** All underground pipelines shall be installed in accordance with these standards and tested as outlined below. These are minimum requirements and additional testing may be required.

**4.4.3.1 TRENCH BACKFILL MOISTURE/DENSITY TESTING.** Minimum testing of trench backfill shall be as follows:

Soil Proctor	One determination for each significant change in soil type as necessary to provide required compaction testing. Tests shall be ASTM D-1557 Method A or D (modified proctor).
--------------	--

Trench backfills moisture/density determination -	Tests are required for trench backfill for every two hundred (200) lineal feet of trench or portion thereof and all service laterals (2 tests for every lateral), valve locations and manholes every two (2) feet vertical. Tests shall be run at the following trench elevations:
---	--

One test at top of pipe zone.

One test per two (2) feet of depth measured from the bottom of the subgrade to the top of the pipe zone. Tests shall be evenly spaced vertically through the trench with one (1) test at top of trench (bottom of subgrade) includes lineal trench, manholes, and valve locations. Service laterals shall have a minimum of two test per lateral.

Additional testing may be required by the city's representative or soils testing laboratory to verify compaction.

Tests shall be according to ASTM D-1556 or D-2922 and D-3017. Moisture/density determinations shall be made in accordance with Section 3 of these standards. Proctors for all trench backfill compaction shall be determined using ASTM D-1557 modified proctor method

**4.4.3.2 SANITARY AND STORM SEWER LINE TESTING AND ACCEPTANCE.**

This subsection specifies requirements for the testing and acceptance of all sewer systems. Prior to testing, all sewer lines shall be cleaned. On main lines, invert elevations of the inlet/outlet of each manhole and the distance measurements between manholes shall be verified with surveying practices prior to installation of manhole floor. For service laterals, grades shall be verified by a carpenter's level or surveying instruments. All sewer trench compaction testing shall be completed and approved prior to performing air and deflection tests. The sewer lines, service laterals and manholes shall be tested for leakage and alignment in the presence of the City's Representative as follows.

**A. DISPLACEMENT TEST.** The displacement test shall be conducted by the Contractor in accordance with the following procedure.

A light shall be flashed between manholes or, if the manholes have not yet been constructed, between the locations of the manholes, by means of a flashlight or by reflecting sunlight with a mirror. If the illuminated interior of the pipe shows broken, misaligned, or displaced pipe, or other defects, the defects identified by the city's representative shall be remedied by the Contractor. After cleaning and inspection have been completed, the line shall be tested for leakage.

**B. AIR TESTING.** The air test shall be performed on all sanitary sewer and other storm sewer lines as directed by the city's representative. This test applies to all types of pipes. When concrete pipe is used, it shall be pre-wetted prior to testing.

The reach of pipe to be tested shall be isolated by completely plugging all outlets in the section under test. Careful attention shall be given to blocking all plugs. Prior to installing the lower and upper plugs, any concrete pipe and manholes used shall be wetted to minimize any loss of air through the pipe or manhole walls because of permeability in the dry condition. One of the plugs used at the manhole must be equipped to control the air entry rate and to prevent the pressure from exceeding five p.s.i.g. which shall be done by means of a blow-off valve set to operate at five p.s.i.g.

After the plugs are installed (and any concrete pipe has been wetted) the air shall be allowed to slowly fill the pipe until a constant pressure of four p.s.i.g. is maintained for at least two minutes. During the two-minute stabilization period, all plugs and exposed fittings shall be checked with a soap solution. If a leak is found, the air shall be bled off, the leak repaired and a new two-minute stabilization period begun. When the temperature of the air has reached equilibrium with that of the pipe wall, the air pressure shall be brought to four p.s.i.g. and the supply shall then be disconnected. When the pressure gauge reaches three and one-half p.s.i.g., a stopwatch shall be started. The watch shall then be stopped when the pressure

reaches two and one-half p.s.i.g. The time shown on the watch for a loss of one p.s.i.g. at an average pressure of three p.s.i.g. is used to calculate the rate of air loss. The pipeline may be considered to have passed the air test successfully if the loss of air is not greater than a rate of 0.0030 cubic feet per minute per square foot of internal pipe surface. The following table shows the allowable time for the pressure to drop from three and one-half to two and one-half p.s.i.g. for respective pipe diameters.

**TABLE 4.6  
AIR TESTING**

Pipe Diameter	Time Min. Sec.	Pipe Diameter	Time Min. Sec.
6-inch	3 0	18-inch	8 30
8-inch	3 45	20-inch	9 30
10-inch	4 45	21-inch	10 0
12-inch	5 45	24-inch	11 15
14-inch	6 30	27-inch	12 45
15-inch	7 0	30-inch	14 0
16-inch	7 30	36-inch	17 0

**C. EXFILTRATION TEST.** In lieu of the standard air test, the Contractor may make an exfiltration test in accordance with the following procedure:

The test section shall be plugged at both ends and the pipe subjected to a hydrostatic pressure produced by a head of water at a depth of three feet above the invert of the sewer at the upper manhole under test. In areas where ground water exists, the head of water shall be three feet above the existing water table.

For concrete pipe, the three-foot head of water shall be maintained for a period of one hour to obtain full absorption of the pipe body and thereafter for a further period of one hour for the actual leakage test. For all other types of pipe, the three-foot head of water shall be maintained for a period of one hour only. During the one-hour test period the measured maximum allowable rate of exfiltration for any section of sewer, including service stubs, shall be as listed below

**TABLE 4.7  
EXFILTRATION TEST**

Sewer Main Diameter (inches)	Maximum Drop in Head in a 4-ft. Diameter Manhole (Non-taper sect.) per 100 ft. of sewer pipe	Maximum Allowable Leakage (Exfiltration) (Gallons/Hour/100 ft.)
6	0.1563 inch	1.2
8	0.2031 inch	1.6
10	0.2500 inch	2.0
12	0.3125 inch	2.4
15	0.3594 inch	2.8
18	0.4063 inch	3.2
21	0.4531 inch	3.6
24 or larger	0.5156 inch	4.0

When measurements indicate an exfiltration greater than the maximum allowable leakage, additional measurements shall be taken and continued until all leaks are located and the necessary repairs and corrective work have reduced the leakage in the section being tested below the maximum allowable by these standards. For purposes of the exfiltration test, the line between adjoining manholes will be considered a section and will be tested as such.

The Contractor shall furnish the plugs and other material and labor for placing the plugs in the sewer and shall assist the city's representative in making all measurements required. The introduction of any substance into the testing water with the intent of sealing leaks will not be permitted.

When the results of the air test or the exfiltration test is not satisfactory, repairs or pipe replacement shall be required until the city's representative is satisfied that the leakage requirements have been met. All repair methods and materials used shall be approved and accepted by the city's representative.

**D. PVC DEFLECTION TEST.** All PVC sewer pipe shall be tested for deflection with a mandrel. The mandrel shall be a rigid device sized to pass through a pipe having five percent or less deflection. These allowances shall include deformations due to all causes (wall thickness variations, shipping, production, backfill, heat, etc.). The mandrel device shall be cylindrical in shape and shall comply with the manufacturer's recommendations.

The mandrel shall be hand pulled through all sewer lines. Any sections of sewer not passing the mandrel shall be uncovered and repaired by the Contractor. The Contractor shall re-round or replace the sewer to the

satisfaction of the city's representative. All repaired sections shall be re-tested as noted above.

Deflection tests shall be conducted only after the final trench backfill is placed to final grade and compacted.

**E. INSPECTION AND FLUSHING.** Prior to final acceptance of each section of sanitary and storm sewer lines, all lines shall be flushed by the Contractor. All dirt and debris shall be prevented from entering the existing sewer system by means of water-tight plugs or other suitable methods.

Upon completion of the project, the contractor will video with the city's representative present and inspect all sewers and appurtenances. Any unsatisfactory work shall be removed and replaced in a proper manner. The invert of the sewer lines and manholes shall be left smooth, clean, and free from any obstructions throughout the entire line. All manhole rings and covers shall be adjusted to finished grade, concrete collars installed, and all sanitary sewer laterals shall be properly extended, capped, and marked prior to acceptance of the sewer system.

**F. MANHOLE LEAKAGE TEST.** Sewer manholes located in areas of ground water or probable flooding or if their water tightness is suspect, as determined by the city's representative, shall be tested for leakage prior to acceptance. The contractor shall perform all testing. Allowable leakage shall be one gallon per hour per manhole. At least two manholes shall be tested and based on these tests and visual inspection of all manholes, additional tests may be required for other manholes. Any manhole which tests unsatisfactorily shall be repaired and retested until satisfactory results are obtained.

**4.4.3.3 WATER SYSTEM TESTING AND ACCEPTANCE.** The Contractor shall test all water mains prior to final acceptance. Testing shall be done in the presence of the City Public Works Department representative. When existing facilities must be included in the test and are determined to be faulty and not capable of holding test pressures, the existing facilities must be repaired prior to testing. When concrete thrust blocks are used, they shall be in place at least five days prior to initial filling of the line. (If high early strength concrete is used, three days will be required.)

**A. PRESSURE TEST.** After the pipe has been laid, including fittings, valves, corporation stops, services, and hydrants, and the line has been backfilled in accordance with these standards, each valved section, unless otherwise directed by the Public Works Department, shall be subjected to a hydrostatic pressure test of not less than two hundred pounds per square inch. The duration of each such test shall be two hours. Water added to maintain the pressure shall not exceed 0.3 gallons per inch diameter per one thousand lineal feet of pipe being tested during the two-hour test period.



Each valved section of pipe shall be slowly filled with water, and the specified test pressure measured at the lowest point of elevation. The pressure shall be applied by means of a pump connected to the pipe in a satisfactory manner. The pump, pipe connection, gauges, and all necessary apparatus for the test must be furnished by the Contractor. Gauges and measuring devices must be approved by the Public Works Department and the necessary pipe taps shall be made as directed. Before applying the specified test pressure, all air shall be expelled from the pipe by a method approved by the Public Works Department.

Any cracked or defective pipes, fittings, valves, or hydrants discovered in the pressure test shall be removed and replaced with new materials in accordance with the standard specifications. The test shall be repeated until the water main passes the pressure test and is accepted by the City's Public Works Department or city's representative.

Bacteriological Testing. After the pipe has been pressure tested in accordance with these standards, each valved section, unless otherwise directed by the Public Works Department, shall be verified negative for the presence of bacteria.

**B. OPERATIONAL INSPECTION.** At the completion of the project and in the presence of the city's representative, the Contractor shall operate all valves, hydrants, and water services to ascertain that the entire facility is in good working order; that all valve boxes are centered, and valves are operational; that all hydrants operate and drain properly, and that water is available at all meter boxes.

**C. TEST RESULTS AND CERTIFICATES OF COMPLIANCE.** Test results shall be submitted for pressure and operational testing in accordance with current City Public Works Department requirements. Certificates of compliance from material suppliers may be required, at the option of the city's representative, for any materials not specifically covered herein.

**4.5 ROADWAY CONSTRUCTION.** This subsection covers roadway construction including subgrade, subbase, road base, recycled aggregate materials (RAM), prime coat, tack coat, plant mix bituminous surfaces (dense and open graded), construction staking and other related work.

**4.5.1 GENERAL REQUIREMENTS.** The Contractor shall furnish all labor, material, equipment, tools, transportation, traffic control and supplies required to complete the work in accordance with the approved plans and these specifications. The approved plans do not purport to show all the details of the work. The plans are intended to illustrate the character and extent of work required and therefore, they may be, if necessary, supplemented or revised as the work progresses. The Contractor shall always keep the most current set of approved plans available on the job site.

The Contractor shall arrange the work and shall place and dispose of the materials being used so as not to interfere with the public during the project. The Contractor shall join the new work with that of existing in an acceptable manner and shall perform all work in proper sequence.

The Contractor shall provide and maintain or have provided for, all necessary work zone traffic control in accordance with the requirements of Section 2.5 of these specifications. The Contractor shall also maintain the job site and all adjoining private and public areas in a clean, safe manner. This maintenance shall constitute continuous and effective work prosecuted day-by-day, with proper equipment and adequate work forces to keep all areas related to and adjoining the job site in a condition satisfactory to the city's representative. If, at any time, the Contractor fails to comply with these provisions the city's representative will immediately notify the Contractor of such non-compliance. If the Contractor fails to remedy the unsatisfactory maintenance within twenty-four hours after receipt of such notice, the city's representative may immediately proceed to cause correction(s) to the job site and adjoining areas. The entire cost of this corrective maintenance will be billed to the Contractor and shall be paid in full prior to the City's acceptance of the work.

If a condition develops due to a lack of maintenance by the Contractor that is dangerous to public safety, the Contractor shall proceed to immediately remedy the condition with whatever means are available. The entire cost of the corrective remedy will be the Contractor's responsibility.

**4.5.2 CONSTRUCTION STAKING.** Construction stakes shall be furnished and set, establishing lines and grades for roadway excavation including, but not limited to all cut and fill slopes finished subgrade, finished subbase, and finished road base grades for streets, curb & gutter, cross-gutters, sidewalks, drive approaches, any contiguous structures, and utilities (to help prevent conflicts of location). In development related projects the Developer and his Engineer shall be responsible for all surveying and the accuracy thereof.

The line and grade stakes shall be, whenever possible, off-set from the construction area a minimum of five feet and shall show the stationing (corresponding with the approved plans), off-set distance, required cut or fill to the finished grade, flow line, and TBC as indicated on the approved plans. Grade stakes with hubs set to the finished grade of the subgrade shall be painted appropriately. Stakes with hubs set to the finished grade of the subbase or road base shall be painted appropriately. Plastic "whiskers" may be used in connection with painted hubs. All stakes and grades shall be set by appropriate methods under the direction of the professional engineer whose seal is on the approved plans. The Contractor constructing the facilities should be provided with copies of the cut sheets generated during construction staking. Cut sheets shall include roadway stationing, reference elevations, grade elevations, etc.

The line and grade stakes and cut sheets along with the most current set of approved plans shall constitute the field control by which the work shall be executed.

The Contractor shall be responsible for preserving property markers, corner survey markers, construction survey stakes and marks for the duration of their usefulness.

If any construction survey stakes or markers are lost or disturbed and need to be replaced, such replacement shall be done at no expense to the City. At no time shall a permanent monument be removed without prior authorization by the city representative. When construction work encounters such monuments, the Surveyor should be contacted immediately.

**4.5.3 GRADE CONTROL SYSTEMS.** Non-contact grade control systems may be used to establish the roadway elevations of subgrade, subbase and road base on public streets providing the following conditions are met.

A. The system shall be equipped with a "self-diagnostic" function that continuously monitors all system functions and shuts the system down if an error in the system occurs. It shall also be equipped with a "thermistor" to electronically compensate for differences in air and ground temperature with a minimum operating range not less than zero to 160 degrees F. (-18 to 71 degrees C.).

B. The system shall meet the following minimum specifications:

Blade slope sensor resolution	0.01% slope
Main fall sensor resolution	0.01% slope
Rotation sensor resolution	0.1 degree
Tractor grade controller	0.015-foot (4.5 mm) accuracy
Cross-slope resolution	0.1% slope or 0.01 foot/10 foot (3 mm in 3m).
Cross-slope system accuracy	0.02 foot/10 feet (6 mm in 3 m)

C. A system meeting the above requirement must be properly installed on a tight\* properly maintained motor-grader.

\*Meeting the equipment manufacturer's service specification tolerances for all controlling surfaces and connecting points that effect the ability of that specific type of equipment to provide proper grade control.

With all the above conditions met the system will be permitted to be used, providing a preset grade and line for curb & gutter, edge of pavement or curb grade line has been established by the Engineer.

The city's representative has the right to prohibit the use of such equipment, if in his opinion, the equipment has not been properly maintained or is not being properly operated.

**4.5.4 GEOTECHNICAL INVESTIGATION.** A geotechnical investigation shall be conducted under the direction and control of a Geotechnical Engineer experienced in flexible pavement design. The investigation shall include a thorough exploration and sampling program of the subgrade to determine the nature and engineering properties of the on-site soils within the roadway construction areas. The minimum sampling and testing requirements shall be as outlined in Section 3.2.5 and where

otherwise outlined in these specifications.

If the geotechnical investigation was completed more than 3 years (1095 Days) prior to the project submittal date, then it's no longer valid without a current updated letter/report indicating that the original investigation remains valid. The structural details shown on the plans and/or Standard Drawings, and Table 4.2 are minimum requirements. The actual structural section for each roadway shall be designed by accepted engineering design methods for flexible pavement (i.e., AASHTO, UDOT, Caltrans). Required subgrade soil properties shall be obtained from an on-site geotechnical investigation. Required traffic design traffic information is provided in Table 4.2. When, in the opinion of the city representative the traffic information listed is inappropriate for the street under consideration the Traffic Index will be adjusted accordingly.

**4.5.5 ROADWAY SUBGRADE.** This subsection shall govern the preparation of natural, filled, or excavated material prior to placement of subbase. The preparation of subgrade shall extend a minimum of two feet beyond the proposed construction limits. This includes roadways, curbs & gutters, drive approaches, sidewalks, or any other roadway structures.

**4.5.5.1 PREPARATION.** The subgrade soils shall be prepared by scarifying and processing to a minimum depth of one foot unless otherwise recommended by the geotechnical firm approved by the city representative.

Unsuitable material found below the processing depth such as saturated soils from groundwater, expansive soils, soluble soils, deleterious and/or organic materials shall be addressed by a Geotechnical Engineer who shall provide a written recommendation to the city's representative for approval prior to performing any work in the areas being addressed.

**TABLE 4.8  
Minimum Roadway Structural Requirements (Updated)**

Classification	Traffic Index	(3)(4) Roadway Minimum Asphalt Pavement (inches)	(4) Required Roadway Road-Base (inches)	Sidewalk Minimum Concrete Thickness (inches)	Sidewalk Minimum Road-Base Thickness (inches)	Driveway Minimum Concrete Thickness (inches) within R/W	Driveway Minimum Road Base Thickness residential@ (inches) within R/W
Residential Access A	5	3 (1)	6	6	4	6	6
Residential Access B	5	3 (1)	6	6	4	6	6
Residential Standard	5	3 (1)	6	6	4	6	6
Collector	6	3	8	6	4	6	6
Arterial	8	4	8	6	4	8	8
Commercial Local	10	4	8	6	4	8(2)	8
Industrial Local	10	5	12	6	4	9(2)	8

Asphalt pavements containing more than 1% gypsum (CaSO<sub>4</sub>+2H<sub>2</sub>O calcium sulfate, dihydrate) shall be a minimum of 3" thick, consisting of 2" of 3/4" dense-graded asphalt base course containing no more than 2% gypsum and 1" of 1/2" dense-graded asphalt wearing course with less than 1% gypsum. This section will require no prime coat.

- (1) #4 rebar to be placed three inches above the bottom of concrete spaced 12 inches on center each way.
- (2) All wearing courses shall have less than 1% gypsum content.
- (3) Thickness may vary based upon structural section design by a registered professional engineer experienced in flexible pavement design. Minimum values are shown above.

Uniform pervious soils that allow the immediate penetration of water to a depth of one foot, will not require scarifying and processing unless a condition previously stated requires it. When scarifying and processing are not required, the moisture content of the top one foot of the subgrade material shall be brought to not less than two percent of optimum by the addition of water on the surface, and the material shall be compacted by approved equipment to the specified compaction requirements.

When scarifying and processing, the roadbed shall be loosened to a depth of at least one foot, then alternate blading, moistening, and rolling will be required to provide a smooth, even, and uniformly compacted course true to cross-section and grade. Moisture content at the time of processing and testing shall be not less than two percent of optimum. All rocks larger than six inches in diameter shall be removed.

**4.5.5.2 TOLERANCES.** When subbase material is placed on the subgrade the subgrade tolerance shall not vary more than 0.10-foot from the specified grade and cross-section. However, when road base or recycled aggregate materials (RAM) placed on the subgrade the subgrade tolerances shall not vary more than 0.05-foot from the specified grade and cross-section.

**4.5.6 SUBBASE - CLASS I AND CLASS II.** All gravel pits supplying aggregate shall be UDOT approved pits. Materials provided for roadways not from a UDOT approved pit shall obtain testing similar to UDOT approved pits. Subbase for all roadways and associated areas shall consist of select materials, either natural or crushed. Aggregate wear shall be less than fifty percent when tested by AASHTO T-96. The material passing the 40 (4.75mm) sieves shall be non-plastic per AASHTO T-90. The subbase shall contain no more than three percent gypsum or any other deleterious or organic materials by weight.

Prior to delivering any subbase to any site the supplier shall submit, in writing, a job-mix gradation to the city representative for approval. The job-mix gradation shall have definite single values for the percentage of aggregate passing each specified sieve based on the dry weight of the aggregate. Dry weight values shall fall within the band limits shown in Table 4.3.

Annual job-mix gradations shall be submitted in writing to the city representative for approval prior to January 31 each calendar year or upon selection of new aggregate sources. Any revisions to the approved job mix gradations shall fall within the requirements listed above.

If a supplier does not have an approved job-mix gradation that is current for the aggregate source or calendar year, the An Ideal Gradation in Table 4.9 will apply.

The subbase mixture placed on projects for one day's operation shall come from a single source. Intermixing from more than one source will not be permitted.

Subbase material shall be deposited and spread in uniform lifts not to exceed eight inches compacted thickness for Class I- and six-inches compacted thickness for Class II without segregation of size. Each layer shall be compacted for the full width and depth by mechanical means of compaction. When mixing, moistening and placing subbase the moisture content shall be not less than two percent below optimum. However, caution shall be used to avoid over watering to a state of instability. Alternate blading and rolling will be required to provide a smooth, evenly moistened and uniformly compacted course true to cross-section and grade. Locations inaccessible to rolling shall be compacted with mechanically operated hand tampers. The subbase shall be compacted to not less than ninety five percent maximum dry density as determined by ASTM D1557-78 or AASHTO T-180 Method D. Subbase tolerances when compacted shall not vary more than 0.05-foot from the specified grade and cross-section.

**TABLE 4.9  
SUBBASE AGGREGATE GRADATION**

PERCENTAGE OF TOTAL AGGREGATE PASSING					
SIEVE SIZE		CLASS I BAND LIMITS	IDEAL GRADATION	CLASS II BAND LIMITS	IDEAL GRADATION
METRIC	AMERICAN STANDARD				
152.4 mm	6"	100	100	--	--
76.20 mm	3"	90 - 100	95	100	100
50.80 mm	2"	80 - 100	90	90 - 100	95
25.0 mm	1"	70 - 90	80	70 - 90	80
12.5 mm	2"	51 - 75	63	51 - 75	63
4.75 mm	#4	31 - 65	48	31 - 65	48
1.18 mm	#16	16 - 40	28	16 - 40	28
.075 mm	#200	2 - 20	11	2 - 20	11

**4.5.7. UNTREATED ROADBASE - ONE INCH AND THREE-QUARTER INCH.**

All gravel pits supplying aggregate shall be UDOT approved pits. Road base for all

roadways and associated areas shall consist of select materials, natural and/or crushed. Coarse aggregate shall be all material retained on the #4 (4.75 mm) sieve, and shall be crushed stone, crushed gravel, or crushed slag with a minimum of forty percent fractured faces per FLH designation T-506-94. Fine aggregate may be a natural, or manufactured, product and shall pass through a #4 (4.75 mm) sieve. All aggregates shall be clean, hard, tough, durable, and sound containing no more than two percent gypsum and be free from other deleterious and/or organic materials and harmful adherent coatings.

Aggregate wear shall be less than fifty percent when tested by AASHTO T-96 and the material passing the #40 (.0425 mm) sieve shall be non-plastic per AASHTO T-90. The dry-rodded unit weight shall be at least seventy-five pounds per cubic foot (1200 kg/m<sup>3</sup>) per AASHTO T-19.

Prior to delivering any road base to any site, the supplier shall submit, in writing, a job-mix gradation and a standard aggregate gradation plot to the City representative for approval. The job-mix gradation shall have definite single values for the percentage of aggregate passing each specified sieve based on the dry weight of the aggregate. Dry weight values shall fall within the band limits shown in Table 4.4 and provide a uniform curve when plotted on a standard aggregate gradation chart. The city representative has the right to request modification to the job-mix gradation to provide an acceptable curve. The accepted job mix will then become the target gradation for the aggregate source for the calendar year.

Annual job-mix gradations shall be submitted in writing to the city representative for approval prior to January 31 each calendar year, or upon selection of new aggregate sources. Any revisions to the approved job-mix gradation shall fall within the requirements listed above.

If a supplier does not have an approved job-mix gradation that is current for the aggregate source, or calendar year, the "Ideal Gradation" in Table 4.4 will apply.

The road base placed on a project for one day's operation shall come from a single source. Intermixing from more than one source will not be permitted.

Road base shall be placed in layers compatible with the equipment and not exceeding eight (8) inches in non-compacted thickness. Where the required thickness is more than eight inches the road base shall be spread and compacted in two or more layers of approximately equal thickness. However, if vibratory compaction equipment of a type approved by the city's representative is used, and the requirements for density and moisture content are complied with, the noncompacted thickness of any one layer may be increased to ten (10) inches. Each layer shall be compacted for the full width and depth by mechanical means. When mixing, moistening and placing road base the moisture content shall be not less than two percent below optimum. Care shall be used to avoid overwatering. Alternate blading and rolling will be required to provide a smooth, evenly moistened and uniformly compacted course true to cross-section and grade. Locations accessible to rolling shall be compacted with mechanically operated hand



tampers. The road base shall be compacted to not less than ninety five percent maximum dry density as determined by ASTM D-1557-78 or AASHTO T-180 method D. Road base tolerances when compacted shall meet or exceed the required minimum thickness and shall not vary more than 0.02 foot from the specified grade and cross-section at the time the asphalt pavement is placed.

When the road base surface is used to convey traffic or is left unpaved for an extended period, the contractor shall preserve the integrity and grade and an asphalt prime coat meeting the requirements in Section 4.5.8 shall be applied. When asphalt prime is not used, the contractor shall maintain the road base moisture, structural integrity, and finish, to the finished tolerances of this subsection.

**TABLE 4.10  
ROADBASE AGGREGATE GRADATION**

PERCENTAGE OF TOTAL AGGREGATE					
Sieve Size		1 Inch/ 25mm Band Limits	Ideal Gradation	3/4 Inch /19mm Band Limits	Ideal Gradation
Metric	American Standard				
25 mm	1"	100	100	--	--
19 mm	3/4"	--	--	100	100
12.5 mm	1/2"	79 - 91	85	--	--
9.5 mm	3/8"	--	--	78 - 92	85
4.75 mm	#4	49 - 61	55	55 - 67	61
1.18 mm	#16	27 - 35	31	28 - 38	33
.075 mm	#200	7 - 11	9	7 - 11	9

**4.5.8 CBR TEST.** A CBR Test (California Bearing Ration) shall be performed prior to the placement of asphalt or concrete. The test shall be performed as described in ASTM Standards D1883 and D4429 and AASHTO T193. The minimum CBR value shall be 60.

**4.5.9 TACK COAT.** This work shall consist of preparing and treating an existing bituminous or concrete surface with asphaltic emulsion in accordance with these specifications and in conformity with the lines shown on the plans or established by the city's representative. The type and grade of bituminous material shall be SS-1h asphalt emulsion, unless otherwise directed.

Asphalt emulsion used as a tack coat between courses of plant mix surface, or over an existing surface, shall be prepared for application by using warm water to cut back the emulsion in the quantity of fifty percent of the emulsion by weight.

Bituminous material shall be applied to the width of the section to be tacked by means of a pressure distributor in a uniform, continuous spread. Care shall be taken that the application of bituminous material at the junctions of spreads is not more than the specified amount. Skipped areas or deficiencies shall be corrected.

The Contractor shall provide equipment for heating and applying the bituminous material. The asphalt distributor shall be so designed, equipped, maintained, and operated that bituminous material will be applied uniformly on variable widths of surface at readily determined and controlled rates from 0.05 to 2.0 gallons per square yard with uniform pressure and with an allowable variation from any specified rate not to exceed 0.02 gallon per square yard. Distributor equipment shall include a tachometer, pressure gage(s), accurate volume measuring devices or a calibrated tank, and a thermometer for measuring temperatures of tank contents. Distributors shall be equipped with a power unit for the pump and full circulation spray bars adjustable laterally and vertically.

Application of tack coat may occur only when the surface and air temperature is 50 degrees F. (10 degrees C.) and rising. The surface shall be clean, dry, free of irregularities, and shall be smooth and uniform.

At the time of placement, the temperature of the asphaltic emulsion shall be uniform and not less than 75 degrees F. (24 degrees C.) nor more than 130 degrees F. (54 degrees C.). The tack shall be applied at a rate of 0.05 to 0.10 gallon per square yard. The rate of application may be adjusted by the city's representative.

Liquid asphalt shall not be sprayed upon adjacent pavements, structures, railing, barriers, markers, adjacent property improvements, and other facilities not mentioned herein.

**4.5.10 DENSE-GRADED ASPHALT.** A marshal mix design must be submitted and approved along with certification from an independent lab prior to the placement of any asphalt. This work shall consist of mixing, laying, and compacting an asphalt course, of one or more layers composed of aggregate, asphalt cement, applicable additives, and lime, as required. All materials shall be mixed at a central mixing plant.

**4.5.10.1 MIX DESIGN.** Annual mix designs with independent lab certification and a minimum binder content of 5.2% shall be submitted in writing to the city representative for approval two weeks prior to the first job each calendar year, or upon selection of new aggregate sources.

**4.5.10.2 RECYCLED ASPHALT PAVEMENT (RAP).** Recycled asphalt pavement will be permitted for use in mix designs from carefully processed and uncontaminated stockpiles. The maximum percentage allowed will be 20% as determined from the aggregate contribution from the RAP to the overall mix. Any mix proposed with a RAP contribution > 10% must drop to the next lower grade for virgin liquid asphalt used for the mix.

Examples:

- A mix design is desired for a Category I roadway using an AC–30 and there is a desire to use RAP at 15%. This is acceptable so long as the virgin liquid asphalt is changed to an AC–20 or a PG 64-22.
- A mix design is desired for a Category II roadway using a PG 64-22 and there is a desire to use RAP at 10%. This is acceptable with no change to the proposed virgin liquid asphalt.

Provide the services of an independent testing company to calculate the percentages of RAP processed at the plant for placement. If the percentages of RAP exceed the limits presented above, the testing company will contact the city representative for rejection of the RAP prior to placement. Any placed RAP that does not meet the specification will be removed at no additional cost to the city.

**4.5.10.3 RELATED WORK.** Work related to asphalt concrete pavement shall include surface preparation, prime coat, tack coat, transporting, placement, compaction and finishing of asphalt mixture as required. Work zone traffic control shall be in accordance with the requirements of Section 2.5 of these specifications.

**4.5.10.4 ASPHALT CEMENT.** Viscosity graded asphalt cement shall meet

AASHTO designation M-226-80 (1993). Viscosity is to be measured at 140°F (60°C) when used in pavement construction. The asphalt cement shall be homogeneous, free from water, and shall not foam when heated to 347° F (175° C). Sampling and testing of asphalt cements shall be in accordance with the following AASHTO Standard Methods:

- Sampling T40
- Viscosity at 140°F (60°C) T202
- Viscosity at 275°F (135°C) T201
- Penetration T49
- Flash point (COC) T48
- Solubility in bituminous materials T44
- Thin-film oven test T179
- Ductility T51
- Spot test T102
- Rolling thin film oven test T240
- Water T55

The asphalt cements shall conform to the requirements given in Table 4.5.

**TABLE 4.11  
Paving Grade Liquid Asphalt Requirements**

Traffic Category*	Category II		
		Category I	
AC	AC-10	AC-20	AC-30
PG	58 - 28	64 - 22	70 - 16
Viscosity: 140° (60°C) poises	1,000 ± 200	2,000 ± 400	3,000 ± 600
Viscosity: 275°F (135°C), Cs-minimum	250	300	350
Penetration: 77°F (25° C), 100g, 5 sec-min.	80	60	50
Flash Point: COC, C(F)-minimum	219(425)	232(450)	232(450)
Solubility in trichloroethylene: percent-minimum	99.0	99.0	99.0
Tests on residue from thin-film oven test:			
Loss on heating: percent - maximum (1)	0.5	0.5	0.5
Viscosity: 140°F (60°C), poises-maximum	4,000	8,000	12,000
Ductility: (77°F (26°C), 5cm per minutes), cm- minimum	75	50	40
Spot test (when and as specified (2) with: Standard naphtha solvent	Negative for all grades		
Naphtha-Xylene-solvent, % Xylene	Negative for all grades		

Hepthan-Xylene-solvent, % Xylene	Negative for all grades
----------------------------------	-------------------------

1. The use of loss on heating requirement is optional.
  2. The use of the spot test is optional. When it is specified, the city representative shall indicate whether the standard naphtha solvent, the naphtha-xylene solvent, or the heptane xylenesolvent will be used in determining compliance with the requirement. If xylene solvent is used the percentage of xylene shall be indicated.
- \* Traffic Category I applies to all arterial streets or routes with a Traffic Index of six (6) or more.  
 Traffic Category II applies to streets with a Traffic Index of less than six (6).

**4.5.10.5 SHIPMENT OF ASPHALT MATERIAL.** Asphalt cement shall be uniform in appearance and consistency and show no foaming when heated to the specified loading temperature. Shipments of asphalt shall not be contaminated with any other type or grade of asphalt material. A bill of lading shall accompany each shipment of material and shall include the following information:

- Type and grade of material
- Type and number of additives used, if applicable.
- Destination
- Consignee's name
- Date of shipment.
- Truck identification
- Loading temperature
- Net weight or net gallons corrected to 60°F (16.6°C).
- Specific gravity
- Bill of lading number
- Manufacturer of asphalt material

**4.5.11 HYDRATED LIME FOR ASPHALT MIXTURE.** Lime shall be used in all asphalt mixtures at a rate of 1% or greater of the total virgin aggregate in the mix. The physical properties of hydrated lime shall conform to ASTM C-1097, subparagraph d.1; use test method ASTM C-110, paragraph 6.

The water used in saturating the aggregate to be coated shall be potable or water that is clean and free of dirt, silt, and other damaging material. Hydrated lime shall be applied at a rate determined during the Marshall Design requirements in Table 4.6, unless otherwise directed by the city representative. Two options for coating the aggregate with lime are as follows:

- A.** Aggregate shall be monitored for SSD by taking a belt cut between the stockpile and the pug mill or drum. The pug mill or drum shall be equipped with metering devices that will introduce the required amount of hydrated lime and water into the mixer to produce an aggregate SSD of one and one-half (1½) percent to three (3) percent.
- B.** Use of lime slurry of one (1) part lime and three (3) parts water by volume may be used, if the plant is equipped with a mixing chamber that can maintain the lime suspension in the slurry. Spray bars for

introducing the required quantity of slurry into the mixer shall be equipped with a positive shutoff.

Asphalt plants shall provide a positive signal system that automatically closes the cold feed when the appropriate amount of hydrated lime and water ceases to be introduced into the aggregate. This shall be accomplished using interlocked and synchronized metering devices and feeders. The plant shall be equipped in such a way that the quantity of hydrated lime incorporated into the mix can be readily checked at any time.

**TABLE 4.12  
MARSHALL DESIGN REQUIREMENTS**

TRAFFIC CATEGORY*	I		II	
ASTM D-1559 (number of blows)	75		50	
TEST PROPERTY	MIN	MAX	MIN	MAX
MARSHALL STABILITY, LB.	1500	--	1200	--
FLOW, 0.01 IN	8	16	10	18
AIR VOIDS: PERCENT	3	5	3	5
VOIDS IN MINERAL AGGREGATE (VMA)	SEE TABLE 4.6A			
FRACTURED FACES RETAINED ON THE NO. 4 (4.75 mm) SIEVE PER FLH DESIGNATION: T-506-94 2.1	95%	---	75%	--
SAND EQUIVALENT PER AASHTO T-176-86 (1993) 4.3.2, 4.3.3	55	---	40	--
WEAR TEST AASHTO T-96	---	30%	---	30%
DRY-ROTTED UNIT WEIGHT AASHTO T-19	AM. STD.	METRIC	AM. STD.	METRIC
	75 pounds per cubic foot	1200 kg/m <sup>3</sup>	75 pounds per cubic foot	1200 kg/m <sup>3</sup>
STRIPPING TESTS:  AASHTO T-283  ASTM D-4687 including Note 5	Shall be used to determine the required amount of hydrated lime in the asphalt. The mix design shall have a tensile strength ratio of 70 percent.			

\* Traffic Category I applies to arterial streets or truck routes with a Traffic Index of six (6) or more. Traffic Category II applies to streets with a Traffic Index of less than six (6).

**TABLE 4.12A  
MINIMUM PERCENT VOIDS IN MINERAL AGGREGATE (VMA)**

Nominal Maximum Particle Size <sup>1</sup>	Design Air Voids, Percent <sup>2</sup>		
	3%	4%	5%
Inch			
3/4"	12	13	14
1/2"	13	14	15
3/8"	14	15	16.5

1 – Nominal Maximum Particle Size is one size larger than the first sieve to retain more than 10%.

2 – Interpolate minimum void in mineral aggregate (VMA) for design air void values between those listed.

**4.5.12 AGGREGATE.** The requirements for crushed rock, rock dust, gravel, stone, slag, and sand are included in this subsection. All aggregate shall be clean, hard, sound, durable and uniform in quality. The quality of soft, friable, thin, elongated, laminated pieces and disintegrated materials will be determined by the supplier's professional Geotechnical Engineer at the time the mix design is submitted, at which time the city's representative will have the option to approve or reject the material. Organic matter, oil, alkali, or other salts shall not exceed two percent total weight. In the surface course this material may be restricted to less than one percent by weight.

- A.** Aggregate for three-quarter (3/4) inch (19.0 mm) Category I (NR), (see Table 4.7) shall be one hundred (100) percent crushed material (all manufactured). This is considered a non-rutting (NR) mix.
- B.** Coarse aggregate for three-quarter (3/4) inch standard (19.0 mm standard) and one-half inch (12.5 mm) Category II (see Table 4.7) shall be retained on the No. 4 (4.75 mm) sieve and shall have no less than seven-five (75) percent fractured face material as defined in AASHTO T335.
- C.** Fine aggregate for other than the three quarter (3/4) inch NR, may be a natural or manufactured product. It shall pass the No. 4 (4.75 mm) sieve. It shall be clean, hard-grained angular, non-plastic, and have no more than two percent by weight of organic matter or other detrimental substances, including gypsum.
- D.** Surface courses, or asphalt wearing courses, shall be free from organic materials and contain less than one percent by weight of soluble minerals, such as gypsum, and phosphates.



**TABLE 4.13  
DENSE-GRADED ASPHALT AGGREGATE GRADATION**

PERCENT OF TOTAL AGGREGATE PASSING (DRY WEIGHT)				
TRAFFIC CATEGORY		I	II	
METRIC		19.0 mm NR	19.0 mm std.	12.5 mm
AMERICAN STANDARD		3/4-inch NR	3/4-inch std.	½ inch
SIEVE SIZE				
METRIC	AMERICAN STANDARD			
25.0 mm	1 inch	---	---	---
19.0 mm	3/4 inch	100	100	---
12.5 mm	½ inch	74 - 99	---	100
9.5 mm	3/8 inch	69 - 91	75 - 91	---
4.75 mm	#4	49 - 65	46 - 62	60 - 80
2.36 mm	#8	33 - 47	---	---
1.18 mm	#16	21 - 35	22 - 34	28 - 42
.300 mm	#50	6 - 18	11 - 23	11 - 23
.075 mm	#200	2 - 6	3 - 7	3 - 7

**4.5.13 STORING, MIXING AND SHIPPING OF PLANT MIX BITUMINOUS PAVEMENTS.** Hot mix plants may be batch or drier-drum type plants (with not less than four aggregate bins).

**4.5.13.1 STORAGE.** The various natural and manufactured aggregates shall be stored separately. The various aggregate sizes shall be placed in bins which allow the material to be properly and evenly fed to the dryer to ensure a uniform flow of properly combined aggregates. When placing materials in storage bins, or when moving them from storage to the feeder, no method will be used which may cause segregation, degradation, or the intermingling of different size aggregates. Materials not meeting the gradation requirements shall be reprocessed to comply with the requirements. All scales and meters shall be certified and sealed by the Utah Department of Agriculture, Division of Weights & Measures, annually and when the plant has been moved.

**4.5.13.2 BATCH PLANT METHOD.** The aggregates shall be dried and heated for sufficient time in the dryer so that the moisture content of the aggregate will not be greater than one percent. The dryer shall be equipped with a calibrated thermometer to determine the temperature of the aggregate leaving the dryer. The thermometer shall be accurate to the nearest 10°F (5.5°C) and shall be installed in such a manner that a fluctuation of 10°F (5.5°C) in the aggregate temperature will be indicated within one minute and be clearly read from the operator's platform.

After drying, the aggregates shall be evenly fed to screens having clear square openings to separate, classify and quantify materials for hot storage bins. The aggregate passing these screens shall be separately stored in individual bins until proportioned into the mixer.

Each bin shall be provided with an opening to prevent overflow into adjacent bins. All overflow material shall be returned to an appropriate storage area for reprocessing.

If a substantial change is made in the cold feed to accommodate the demands of a different type of mixture, the hot storage bins shall be emptied and recharged with the correct materials.

All materials shall be proportioned by weight. The aggregate scales shall be fully automatic, solid-state digital strain-gage transducer with a capacity exceeding one and one-quarter times the total amount of materials to be weighed in one operation. Asphalt binder shall be weighed by a fully automatic scale having a capacity of not more than five hundred pounds (227kg) with one pound (0.45kg) resolution for mixers with a manufacturer's rated capacity of four thousand pounds (1814kg) or less, and a capacity of not more than one thousand pounds (454 kg) with one pound (0.45kg) resolution for mixers with a manufacturer's rated capacity over four thousand pounds (1814kg).

When bag house fines or mineral filler is used, it shall be proportioned by weight or volume. The method used shall uniformly feed the material within ten percent of the required amount.

Mixing shall be done with a twin shaft pug mill-type mixer and shall be operated at the speed recommended by the manufacturer. The paddles shall be of sufficient size and quantity to deliver a uniform mixture.

The weight of the material that may be mixed per batch shall not exceed the manufacturer's rated capacity of the mixer, nor exceed an amount that will permit complete mixing of all the materials. Dead areas in the mixer, in which the material does not move or is not sufficiently agitated, shall be corrected by reduction in the volume of materials or by repairs to the mixing equipment before any further production will be allowed.

The entire batch shall be mixed until all the materials are thoroughly blended.

The batch mixing time will begin on the charging stroke of the weight hopper dump mechanism and conclude when discharge from the mixer has started. The mixer shall be equipped with a time lock which locks the mixer discharge gate for the mixing period and actuates an indicator light visible from the operator's platform.

The aggregate and liquid asphalt drop time into the mixer shall not exceed ten seconds and the time for mixing materials will not be less than thirty seconds per batch. If the city's representative determines that the mixture is not thoroughly blended, and all aggregate properly coated with asphalt cement, the mixing time will be increased to produce a homogeneous material.

The weight-box housings and mixer platform shall provide safe and convenient access with properly sized gates and tracks for sampling the discharged materials.

**4.5.13.3 DRIER-DRUM METHOD.** When a drier drum is used, aggregate shall be fed directly to the mixer drum at a uniform rate and monitored for combined aggregate moisture and gradation by taking belt cut samples. A minimum of one moisture content check and gradation test per day and one moisture and gradation test per five hundred tons (551 tone), or as conditions require, shall be made. The results of these tests shall be kept on logs for review by the city's representative. Sampling and testing may be performed by the manufacturer's properly trained and equipped staff or by an approved testing lab. If sampling is performed by the manufacturer, five percent of the samples shall be split, and a testing firm approved by the City shall verify that the test results accurately represent the product being tested by the manufacturer.

The sample to be split may be selected at random by the manufacturer's quality control team, or the city's representative.

If the cold feed material gradation is outside the allowable mean of deviations of the approved mix design as determined in Section 4.5.24, production shall be stopped until the necessary corrections are made. If the moisture content of the cold feed reaches five percent, production shall be stopped until certified by an approved independent materials testing firm under the direction of a Registered Professional Engineer, licensed in the state of Utah. This firm shall then be employed to provide continuous plant quality control and testing, and production may be resumed.

All production shall be prohibited if the cold feed material reaches seven percent moisture, without exception. During lay down operations, if in the opinion of the City's Representative excess moisture is present in the asphalt material, it shall be sampled and tested for moisture under AASHTO T-164-94 Note-6 or ASTM D 2172-93 Note 3. Asphalt found to contain excess moisture shall be removed in its entirety and properly disposed of.

The drier drum shall be equipped with a calibrated thermometer to determine the temperature of the mixed materials leaving the drum. The thermometer shall be accurate to the nearest 10°F (5.5°C) and shall be installed in such a manner that changes of 10°F (5.5°C) in temperature of the mixed material will be shown within one minute and be clearly read from the operator's station.

Asphalt cement shall be measured through a meter under constant pressure with a gage always indicating the pressure and temperature. This metering system shall be calibrated and certified for accuracy every six months, or whenever the plant is moved.

During any day's run, the temperature of asphalt cement shall not vary more than 50°F (10°C). If the meter loses pressure the operator's computer shall be equipped to warn the operator or automatically shut down the system.

The aggregate feeders for each material in the mixture and for the combined aggregates shall be equipped with devices by which the rate of feed can be determined while the plant is in full operation. The combined aggregate shall be weighed on a belt scale. The scale shall be of such accuracy that, when the plant is operating between thirty and one hundred percent of belt capacity, the average difference between the indicated weight of the material delivered and the actual weight delivered will not exceed one percent of the actual weight for three two-minute runs. For any of the three individual two-minute runs, the indicated weight of material delivered shall not vary more than two percent from the actual weight delivered.

The belt scale for the combined aggregate, the other proportioning devices for additives and the asphalt cement proportioning percent and one hundred percent of belt capacity, the average difference between the indicated weight meter shall be interlocked so that the rates of feed will be automatically adjusted to maintain the proper material ratios as designated by the approved mix design. The plant shall not be operated unless this automatic system is operable and in good working condition.

The asphalt cement meters, additive feeders and aggregate belt scales used for metering the aggregate additives and asphalt cement into the mixer shall be equipped so that the actual quantities of asphalt cement, additives and aggregate introduced into the mixture can be determined.

Mixing shall be performed for sufficient time, and at a sufficiently high temperature, so that at discharge from the mixer, the sizes of aggregates are uniformly distributed throughout the completed mixture and all particles are thoroughly and uniformly coated with asphalt cement.

Temperature of the completed mixture at discharge from the drum shall not exceed 325°F (163°C) for all dense-graded mixes using AC-10, AC-20, and AC-30 grades of asphalt cements. Maximum temperatures for open-graded mixes using AC-20 and AC-30 shall not exceed 275°F (135°C). Open-graded mixes using AC-20R shall not exceed 325°F (163°C).

The mixed material shall be discharged from the drum into a surge silo of not less than forty tons in capacity. The manufacturer shall also provide a means of diverting the flow of material away from the silo, when starting and stopping the plant production, to prevent incompletely or improperly mixed portions of the mixture from entering.

Paving grade asphalts shall be added to the aggregates, in both batch and

drier-drum plants, at a temperature between 285°F (140°C) and 350°F (177°C). The temperature of the aggregates at the time of adding the asphalt cement shall not be less than 265°F (130°C), or more than 325°F (163°C). A thermometer with a 500°F (260°C) capacity, and accurate to 10°F (5.5°C) will be fixed in the asphalt cement feed line or storage tank at a suitable location to view when sampling the asphalt. The manufacturer will provide a suitable sampling outlet in the asphalt cement feed lines connecting the storage tank(s) to the asphalt cement meter. The sampling valve shall consist of a one-half inch (12.7 mm) or three-quarter inch (19 mm) valve constructed in such a manner that a one-quart (.95 liter) sample may be withdrawn slowly at any time during plant operations. The sampling valve shall be placed in the least hazardous location that is readily accessible. A drainage receptacle shall be provided for flushing the valve prior to sampling. One gallon (3.8 liters) shall be drawn from the sampler prior to taking the sample.

**4.5.14 ASPHALT CONCRETE SURGE AND STORAGE SILOS.** The type of conveying equipment used to deliver the hot-mix asphalt from the discharge chute on the drier-drum mixer or from the hopper under the pug mill may be either a variable or constant speed - bucket elevator, drag slat conveyor or hot material belt conveyor.

The manner, in which the mix exits from the conveyor or elevator and enters the top of the silo, shall be such as to prevent segregation of the completed asphalt mixture. Properly installed, maintained, and operated systems such as rotating spreader chutes, batchers and gob hoppers are all acceptable segregation prevention systems. Splitter systems, or a series of baffles, may be used providing they are approved by the city's representative.

Silos shall be cylindrical with conical bottoms providing a minimum angle of 55° and maximum angle of 70°. The gate opening in the bottom shall be sized to work with the angle of the cone to prevent center draw down resulting in material segregation.

Heated or insulated surge silos are not required; however, a heated discharge cone is preferred.

The asphalt mixture that develops lumps and hardening or chills below 250° (120°C) while the mix heats, the silo and discharge cone shall not be used. All surge silos shall be emptied of mix at the end of each production day.

Storage silos shall be well insulated and equipped with heated discharge cones and well-sealed discharge gates. Dense-graded asphalt may be stored up to forty-eight hours in silos with heated cones, and seventy-two hours with heating of the silo vertical walls and cone. Storage silos may be used for storage or surge purposes, but under no circumstance may a surge silo be used for storage. Either silo must be equipped with high and low indicator systems.

**4.5.15 SHIPPING ASPHALT MIXTURES.** Trucks used for hauling mix shall have tight, clean, smooth beds which are treated to prevent the mix from adhering to the bed. Amounts of solution that form visible pools in the truck bed shall be removed prior to loading asphalt mix.

Asphalt mix shall be deposited in a mass into the haul truck or loading hopper from the silo. The gates on the bottom of the silo cone shall open and close quickly. To prevent segregation, it is also necessary for the gates to open completely so that the flow of mix is unrestricted. The mix shall be delivered in evenly divided drops into the length of the truck bed. In no case shall the truck be loaded continuously by the truck driver moving forward under the silo as the mix is being discharged. Multiple drops of small quantities or dribbling mix into the haul vehicle at the end of the main delivery should be avoided to prevent segregation.

**4.5.16 SURFACE PREPARATION FOR ASPHALT OVERLAYS.** Prior to placing asphalt overlays, all manholes, utility covers, monuments and other items affected by the paving operations shall be located, referenced and protected. The existing asphalt surface shall be thoroughly cleaned of all deleterious materials and brought to a uniform grade by spot leveling or by the application of a bituminous leveling course to the surface. A bituminous tack coat shall be applied to the existing prepared surface immediately prior to placing the finish asphalt course in accordance with Section 4.5.9 of these specifications. It may be required to remove a section of pavement at each end of the overlay to create a smooth transition onto existing asphalt. A minimum eight-foot-wide section must be removed. Edges of the section must be saw cut prior to removal. Feathering of the overlay onto existing asphalt will not be permitted.

**4.5.17 ADJUSTMENT OF MANHOLE AND OTHER UTILITY COVERS.** Prior to paving and after road base is placed, all manholes shall be brought to finish asphalt grade using concrete and/or expanded polypropylene (EPP) grade rings. Concrete grade rings shall be “wet set” in a bed of non-shrink grout, EPP grade rings shall be installed per manufacturer’s recommendations, including adhesives. All other utility covers shall be brought to the base grade. Damaged valve boxes, covers, grade rings, cones, flattops, risers, etc. shall be replaced at this time. Manhole cones or flattops that are more than eighteen inches below finish grade shall be raised by using risers under the cone or flattop. Existing road base shall not be contaminated with soil or subbase. Backfill material around adjusted manholes and utilities shall comply with road base standards meeting Section 4.5.7 of these specifications, and be compacted to ninety five percent as determined by ASTM D-1557-78 or AASHTO T-180 Method D. When paving is complete, all utility covers shall be raised to finished grade, including concrete collars, in accordance with standard requirements.

**4.5.18 ASPHALT PAVING EQUIPMENT.** A self-propelled paver with a screed unit that provides a smooth, steady pull on the screed arms shall be used. The screed unit shall strike off, partially compact, and iron the surface of the mat at least twelve feet (3.7 m) wide. The screed unit shall be equipped with automatic controls and heaters and vibrators. The screed plate must be smooth and not excessively worn.

All screed extensions shall be ridged, or hydraulically extendable. The screed extensions shall always maintain the proper elevation and angle of attack to the main screed and shall also be heated and provide vibration. Augers shall adequately feed all areas of the extended screed.

The automatic screed controls shall be full contact electronic or non-contact ultrasonic grade control systems. These systems shall be adaptable to a floating-beam system a minimum of thirty feet long. The floating beam shall be equipped with shoes that are allowed to rotate and can be individually displaced by isolated disruptions in the existing surface without changing the height of the whole beam. The automatic grade sensor shall be set at the midpoint of the floating beam.

Ultrasonic grade control systems may only be used on 50' residential streets unless otherwise directed. The ultrasonic grade control system must meet the following conditions to be used without the floating beam.

**4.5.18.1** The system shall be equipped with a “self-diagnostic” function that continuously monitors all system functions and shuts the system down if an error in the system occurs. It shall also be equipped with a “reference bail” to electronically compensate for differences in air and ground temperature with a minimum operating range not less than zero to 160 degrees F. (-18 to 71 degrees

**4.5.18.2** The system shall perform to a minimum of the following specifications:

**Ultra-Sonic Grade Controller**

On- Grade tolerance	0.01 foot
Resolution	0.001 foot
Operating Range	10 in to 42 in
Mat thickness control	0.01 foot

**Slope Controller**

Correction Window	1.0%
On-grade Tolerance	0.1%
Resolution	0.01%
Operating Range	0.0% to 100%

The systems meeting the above requirements must be properly installed on a “tight,” properly maintained self-propelled pavers with a screed unit. A “tight” system shall meet the equipment manufacturer's service specification tolerances for all controlling surfaces and connecting points that affect the ability of that specific type of equipment to provide proper grade control.

The city's representative has the right to prohibit the use of such equipment if in his opinion the equipment has not been properly maintained or is not being properly operated.

If the automatic grade control becomes inoperative, the Contractor may finish

the day's work using manual controls provided the required grade, thickness and smoothness tolerances are met. Paving shall not continue on the project, or any new project, until the automatic control system has been repaired.

**4.5.19 ROLLERS.** Rollers shall be vibratory, steel-wheeled double-drum with a static weight of not less than 10 tons (9.10 tones) for breakdown rolling. Pneumatic-tired rollers with a minimum operating weight of two thousand pounds (907 kg) per tire shall be used for intermediate rolling and leveling course compaction. The roller shall be in good condition, and capable of reversing without backlash. The number of rollers shall be sufficient to compact the asphalt mixture before it cools below 175°F (80°C). Finish rolling may be performed with the breakdown roller in the static mode, or with a steel-wheeled roller of sufficient size to remove the roller marks in the finished surface. If a roller breaks down and a back-up roller is not available, paving operations shall stop until adequate rollers are available.

**4.5.20 WEATHER AND DATE LIMITATIONS.** Asphalt shall not be placed during the period from December 1<sup>st</sup> through February 15<sup>th</sup> unless otherwise approved by the city representative. Paving approved during this time shall conform to winter paving requirements and policies. Minor repairs and patching will be allowed during winter months.

The asphalt mixture shall not be placed upon any wet surface, or when the air and surface temperature of the underlying course is less than specified in Table 4.8. The temperature requirements may be modified, but only when so approved and directed by the City Engineer. Open-graded asphalt mix shall be placed only when the air temperature is 70°F (21°C) and rising, and the surface temperature is a minimum of 60°F (16°C). Air and roadbed temperature shall be measured in the shade. Asphalt mixtures shall not be placed during adverse weather conditions such as rain, wind, hail, etc.

**TABLE 4.14  
CLIMATE LIMITATIONS**

Mat Thickness Wind of 5 MPH or less	Minimum Air and Surface Temperature	
	F	C
3 inches or greater	40°	4°
Greater than 2 ½" inches, but less than 3 inches	45°	7°
Overlay 2 inches or less	50°	10°

**4.5.21 SPREADING AND FINISHING.** The asphalt mix shall be placed upon an approved surface, by a self-propelled paver meeting the requirements in Section



4.5.18. The travel rate of the paving machine shall be regulated to a speed dependent upon the capacity of the mixing plant and/or trucking service to supply the mixture. The paving machine shall be operated so that material does not accumulate and cool below 250° F (121°C) along the sides of the receiving hopper.

Where unavoidable obstacles make the use of mechanical spreading and finishing equipment impracticable, the mixture may be spread, raked with hand tools, and mechanically compacted. For such areas, the mixture shall conform to the required mix design, density, compacted thickness, grade, and cross section.

The asphalt mix may be windrowed in front of the self-propelled pavers properly equipped to transfer the asphalt mix directly into the hopper, provided that the following conditions and requirements are strictly adhered to.

**4.5.21.1** The windrow is properly sized, thereby always insuring the delivery of the correct amount of material to the paving machine.

**4.5.21.2** The asphalt mixture shall be transferred from the windrow to the paving machine in such a manner that the materials in the pavers will be a uniform mixture. The base, upon which the windrow was formed, shall not be disturbed. There shall be a minimum amount of asphalt mixture remaining on the base between the pickup device and the paving machine.

**4.5.21.3** The material in the hopper of the paving machine shall meet with the temperature requirements. Asphalt mixture that does not meet the minimum specified temperatures shall not be used and shall be properly disposed of.

When it is determined by the city representative that the asphalt course being placed by use of a windrow is inferior to that being placed by direct transfer of the asphalt from the hauling vehicle to the spreading machine, the use of the windrow method shall be discontinued.

The asphalt mixture placed using a paving machine for one day's operation shall come from a single plant manufacturer. Intermixing from more than one source shall not be allowed. Intermixing is defined as when more than one plant is used as a routine supply source to a single operation.

The asphalt mixture shall have a temperature not less than 270°F (132°C) or more than 325°F (163°C), at the time the paving machine places the asphalt mixture on grade. Depending on environmental conditions and compaction requirements, the City's Representative may specify more strict temperature requirements.

Asphalt pavement courses of more than three and one-half inches in total compacted thickness shall be placed in two or more courses. One course shall not be placed over another course until the compaction requirements have been met and the mat temperature has cooled to 160°F (71°C) at mid-depth.

Placing of the asphalt pavement shall be as continuous as possible. Rollers should

not pass over the unprotected edge of the freshly laid asphalt mixture. Transverse joints shall be formed by cutting back on the previous run to expose the full depth and proper grade of that course. A tack coat meeting Section 4.5.9 of these specifications shall be applied on the contact surface of the prepared transverse joints just before the new asphalt mixture is placed.

Longitudinal joints shall be spaced in such a manner that joints in succeeding courses will be offset at least twelve inches horizontally from joints in any preceding course. Lanes will be evened up each day to minimize cold longitudinal joints and to provide proper transverse joints. Where possible, the top course longitudinal joints shall be placed a minimum of one foot either side of the lane line.

Transverse joints shall be spaced in such a manner that joints in succeeding passes will be a minimum of five feet horizontally from joints in any adjacent pass. Existing roadway pavements to be widened shall be saw cut far enough into the roadway to provide the proper grade, cross-section, and thickness with a straight vertical longitudinal or transverse joint. These joints shall have a tack coat meeting Section 4.5.9 of these specifications applied on the contact surface immediately prior to paving.

Longitudinal joints on previously compacted passes should have an overlap of new asphalt mixture one to one and one-half inches over the existing mat. Raking should be merely to "bump" the joint, pushing the asphalt mixture off the previous pass and onto the new pass directly over the joint. If the adjacent mat is overlapped too far and too much asphalt mixture is deposited on the existing mat, the excess material shall be pulled away from the new mat rather than being pushed onto the new mat. Excess mix shall never be broadcast across the newly laid asphalt. The excess mix shall be picked up and recycled.

**4.5.22 ROLLING AND COMPACTING.** Compaction equipment shall meet the requirements of Section 4.5.19 of these specifications, unless otherwise approved or required by the City's Representative.

A pass shall be one movement of a roller in either direction. Coverage shall be as many passes as are necessary to cover the entire width being paved. Overlap of passes during any coverage, made to ensure compaction without displacement of material shall be in accordance with good rolling practice.

The breakdown rolling shall consist of one or more complete coverages of the asphalt mat with a vibratory steel-wheeled roller. Initial rolling shall commence at the lowest edge and shall progress toward the highest portion of the asphalt mat. Initial rolling shall not commence on the interior portion of any mat.

The breakdown rolling shall be followed immediately by additional rolling with a pneumatic-tired roller that will provide uniform density throughout the depth of the course being compacted. A minimum of two rollers, one steel-wheeled, and one pneumatic-tired, shall be used. However, the total number of rollers used beyond the minimum of two shall be sufficient to obtain the required compaction while the

asphalt mixture is above 175°F (80°C).

The final rolling of the asphalt mixture shall be performed by a steel wheel roller of sufficient size to remove all roller marks caused during the compaction of the asphalt mixture. The vibratory roller used for breakdown rolling may be used as the finish roller provided it is operated with the vibratory unit turned off.

The rollers shall be kept in continuous motion while rolling so that all parts of the asphalt mixture will receive as close to equal compaction as possible. The roller speed shall be always slow enough to avoid displacement of the pavement. Any displacement occurring because of reversing the direction of the roller, or from any other cause, shall be corrected immediately by use of rakes and fresh asphalt mixture when required.

To prevent adhesion of the asphalt mixture to the rollers, the wheels/tires, bars, pads, and release agent pumps shall be kept properly maintained. The use of diesel oil on pneumatic-tired rollers shall be kept to a minimum and used only in conjunction with coca pads to prevent the asphalt mixture from adhering until the tires heat enough to prevent mix adherence.

The completed surface shall be thoroughly compacted, smooth, and free from ruts, humps, depressions, or irregularities. Any ridges, indentations or other objectionable marks left in the surface of the finished pavement shall be eliminated by rolling or other means. The use of any equipment that leaves ridges, indentations, or other objectionable marks in the asphalt surface shall be discontinued, and acceptable equipment shall be furnished.

Compacting the longitudinal joint shall be performed by placing the roller on the hot un-compacted mat and overlapping the joint by approximately six inches over the cold compacted mat. For proper compaction, the level of the un-compacted mix at the longitudinal joint must be above the elevation of the compacted mix by an amount equal to one-quarter inch for each one inch of compacted pavement. This ratio is "rule of thumb" and may vary slightly depending on the type of asphalt mix and the supplier. A test strip is advisable.

A good source of information for rolling asphalt is a document by AASHTO, FAA, Federal Highway Administration and the National Asphalt Pavement Association entitled "AC 150/5370-14, Appendix 1, and July 31, 1991". The following information is taken from that document.

1. Rolling from The Cold Side - It was common practice in the past to do the initial rolling of the longitudinal joint from the cold (previously placed mat) side of the joint. The major portion of the weight of the roller was supported by the cold, compacted mat. Only six inches or so of the width of the roller hung over the fresh mat, compressing the mix along the joint. Much of the compact effort was wasted because the roller essentially was applying its compact effort to an already-compacted asphalt material.

During the time that the roller was operating on the cold side of the longitudinal joint, the mix on the hot side of the joint, and the rest of the mix in the course being laid, was cooling. Depending on the environmental conditions and the thickness of the mix being placed, the process of compacting, the joint from the cold side often proved to be detrimental to the ability to obtain density on the whole pavement layer.

The reason often given for rolling the joint from the cold side of the joint was that this compaction method allowed the rollers to "pinch" the joint and obtain a higher degree of density. There is no evidence that this is true.

2. Rolling from The Hot Side - The most efficient way to compact the longitudinal joint is to put the roller on the hot mat and overlap the joint by approximately six inches over the cold mat. This places most of the weight of the compaction equipment where it is needed. The mix at the joint is still pushed into the joint area by the roller if the elevation of the new mix at the joint is proper. The longitudinal joint can be compacted effectively by keeping the roller on the new mix, instead of on the previously compacted mix. Any type of roller used for the breakdown rolling of the mix can be employed to compact the longitudinal joint if the elevation of the mix at the joint is above the level of the cold mat and the mix is still hot.

Sometimes the first pass of the roller is completed with the edge of the machine about six inches inside of the longitudinal joint. The theory behind this method of compaction is that the mix will be shoved toward the joint by the roller, and better compaction will be obtained. If the mix being placed is stable enough, the roller should not be able to move the material laterally to any significant degree. If the mix design is proper, this method of compacting the joint does not provide any advantage over moving the first pass of the roller outward one foot (from six inches inside the joint to six inches outside the joint). Rolling the mat by lapping the roller over the adjacent old pavement typically is the more efficient way to provide roller coverage for the whole pavement width.

**TABLE 4.15  
RUBBERIZED LIQUID ASPHALT REQUIREMENTS**

<b>AC-20R:</b>		
<b>Property</b>	<b>ASTM</b>	<b>Specification Min.    Max.</b>
Viscosity @ 140°F, poise	D-2171	1,600 325    2,400
Viscosity @ 275°F, cs	D-2170	70
Pen @ 77°F (100 g, 5 sec)	D-5	450
Flash Point, °F, C.O.C.	D-92	50
Duct. @ 39.2°F, (5 cm/min)	D-113	2.0
cm		110
Rubber, weight %	*	75
Toughness, in-lb.	*	
Tenacity, in-lb	D-2872	
Rolling Thin-Film Oven Test	**	8,000
Tests on Residue:		25
Viscosity @ 140°F, poise	D-2171	
Duct. 39.2°F, (5 cm/min)	D-113	
cm		
<p>* Benson Method of Toughness and Tenacity: Scott Tester, inch-pounds @ 77°F, 20 inches per minute pull. Tension head 7/8-inch diameter.</p> <p>** TFOT ASTM D-1754 may be used. The Rolling Thin-Film Circulating Oven Test is the preferred method.</p>		

**4.5.22.1 SUITABILITY OF AGGREGATE.** The following requirements shall be used to determine the suitability of the aggregate during the mix design:

- Wear shall not exceed thirty percent when tested in accordance with AASHTO T-96.
- The weighted loss shall not exceed twelve percent by weight when subjected to five cycles of sodium sulfate tested in accordance with AASHTO T-104.
- Aggregates consisting mainly of carbonate type rocks shall not be used unless approved by UDOT as satisfactory long-term friction values for comparable traffic volumes when tested in accordance with AASHTO T-242 or ASTM E-274-79.

Aggregates shall be separated into two or more sizes and stored separately.

Stockpiling or handling methods that cause segregation, degradation or the combining of materials of different sizes when placing the aggregate in storage or moving it from storage to the cold bins shall not be used. Any segregated or degraded material shall be re-screened.

**4.5.22.2 MIX DESIGN.** Annual mix designs with independent lab certification shall be submitted in writing to the city representative for approval two weeks prior to the first job each calendar year, or upon selection of new aggregate sources. Any revisions to the approved mix design shall fall within the requirements listed above. Open-graded wearing courses that do not meet the tolerances shown in Section 4.5.24 shall be removed and replaced with material meeting the required gradation. The asphalt cement shall be within 0.10 percent of the mix design. At no time shall the asphalt cement content be such that asphalt slicks form on the surface of the roadway.

Based on the mix design, the open-graded wearing course shall have a tensile strength ratio of seventy (70) percent, or greater, in accordance with AASHTO T-283 UDOT modified. Hydrated lime must be added to the asphalt mix at a rate of not less than 1% of the virgin aggregate in the mix to meet the minimum tensile strength of seventy (70) percent.

**4.5.22.3 MIXING.** The mixing shall be done as specified in Section 4.5.13. The mineral aggregate will be considered satisfactorily coated with asphalt when all particles are coated. During mixing the viscosity of asphalt shall be maintained between four hundred and nine hundred centistokes. The viscosity of polymer-modified asphalt, when used, shall be maintained between one hundred fifty and three hundred (150-300) centistokes.

If a drier drum mixing process is used, the temperature of the mixture shall not be less than 220°F (104°C), or more than 275°F (135°C), when discharged from the mixer. When using a polymer-modified asphalt, the temperature of the mixture when discharged, from mixer should be maintained between 270°F (132°C) and 320°F (160°C). Viscosity will be determined in accordance

with ASTM T-201.

**4.5.22.4 SURFACE PLACEMENT.** Tack coat shall be applied in accordance with Section 4.5.9.

Self-propelled asphalt paving equipment and automatic screed controls meeting the requirements of Section 4.5.18 shall be used. Rollers shall meet the requirements of Section 4.5.19 and shall be a ten ton (9.10 tone) vibratory operated static or a ten ton (9.10 tone) static steel wheeled roller for asphalt pavement finishing.

Paving operations should be planned such that all passes will be brought even “transversely” at the end of each working day. Joints between old and new pavements or between successive day’s works shall ensure continuous bond between adjoining works. Construct joints to have the same texture, density, and smoothness as other sections of the bituminous pavement course. Clean contact surface and apply tack coat.

Offset longitudinal joints a minimum of 12 inches in succeeding courses and at least 6 feet transversely to avoid vertical joints through more than one course. In the top course restrict longitudinal joint to 1 foot either side of the lane line. Prevent traffic, including construction traffic, from crossing vertical joint edges.

Excessive rolling shall not be allowed. Wearing course compaction shall be completed prior to the mix temperature drop below 180°F (82°C). When using polymer-modified asphalt, compaction shall be completed prior to the mix temperature dropping below 200°F (93°C).

Asphalt slicks shall be raked immediately. Slick spots that cannot be removed by raking shall be replaced. All humps or depressions exceeding tolerances shall be corrected. Correction methods shall be approved by the City’s Representative.

All traffic shall be prevented from traveling on the completed wearing course until it has hardened sufficiently, and the surface temperature has dropped below 160°F (71°C). The thickness of the compacted wearing course shall not vary more than one-quarter inch (6.35 mm) from the specified thickness. Testing and acceptance shall conform to Section 4.5.24.

**4.5.23 ACCEPTANCE TESTING REQUIREMENTS AND TOLERANCES.** The following subsections list the requirements for testing and acceptance for subbase, road base, RAM, dense-graded asphalt, open graded asphalt, and asphalt pavement surfaces. Testing documentation shall fully address the requirements of these standards.

**4.5.23.1 SUBBASE.** The following will be required for testing and acceptance of subbase:

- A. One moisture/density test per seven thousand square feet of roadway, or fraction thereof.
- B. One thickness test hole per five thousand square feet.
  
- C. One gradation test per fifteen thousand square feet of roadway, or fraction thereof. The allowable deviations from the approved subbase targets are as follows:

**TABLE 4.16  
SIEVE SIZE AND DEVIATION**

SIEVE SIZE AMERICAN (METRIC)	ALLOWABLE DEVIATION
2" (50.80 mm) to 6" (152.4 mm)	12.1%
2" (12.5 mm) to 1" (25.0 mm)	10.8%
3/8" (9.5 mm)	9.8%
No. 4 (4.75 mm)	8.8%
No. 16 (1.18 mm)	6.9%
No. 200 (.075 mm)	2.9%

C.1 One sand equivalent (*SE*) value for every gradation outside the allowable deviation. A CBR or R-value shall be performed on twenty five percent of all sand equivalent test results with a minimum of one test required. Where multiple SE tests are run, the CBR or R-value shall be determined on those SE tests that exhibit the lowest values.

Any remaining samples with gradations outside the allowable deviations must exhibit the required CBR or R values to be accepted.

The Following Are the Minimum Values for Roadway Subbases.

- The minimum acceptable SE value shall be eighteen.
- The minimum acceptable R-value shall be sixty. <sup>(1)</sup>
- The minimum acceptable CBR value shall be thirty. <sup>(2)</sup>

Note 1: R-value test: AASHTO T-190 or ASTM-D 2844 (300 psi exudation pressure)

Note 2: CBR Value Test: AASHTO T-193, (3 point)

**4.5.23.2 ROADBASE AND RECYCLED AGGREGATE MATERIALS (RAM).**

- A. One moisture/density test per seven thousand square feet of roadway, or fraction thereof.



B. One thickness test hole per five thousand square feet.

C. One gradation test per fifteen thousand square feet of roadway, or fraction thereof. The allowable deviation from the approved roadbase and RAM targets are as follows:

**TABLE 4.17  
SIEVE SIZE AND DEVIATION**

<b>SIEVE SIZE AMERICAN (METRIC)</b>	<b>ALLOWABLE DEVIATION</b>
2" (12.5 mm) to 1" (25.0 mm)	10.8%
3/8" (9.5 mm)	9.8%
No. 4 (4.75 mm)	8.8%
No. 16 (1.18 mm)	6.9%
No. 200 (.075 mm)	2.9%

C.1 One sand equivalent (*SE*) value for every gradation outside the allowable deviation. A CBR or R-value shall be performed on twenty five percent of all sand equivalent test results with a minimum of one test required. Where multiple SE tests are run, the CBR or R-value shall be determined on those SE tests that exhibit the lowest values.

Any remaining samples with gradations outside the allowable deviations must exhibit the required CBR or R values to be accepted.

The Following Are the Minimum Values for Road base and RAM.

- The minimum acceptable SE value shall be twenty-two.
- The minimum acceptable R-value shall be seventy-six. <sup>(1)</sup>
- The minimum acceptable CBR value shall be 60. <sup>(2)</sup>

Note 1: R-value test: AASHTO T-190 or ASTM-D 2844 (300 psi exudation pressure)

Note 2: CBR Value Test: AASHTO T-193, (3 point)

#### **4.5.23.3 DENSE-GRADED ASPHALT PAVEMENTS.**

A. One density test per seven thousand square feet of surface area, or fraction thereof.

B. One core sample per nine thousand square feet, or fraction thereof, unless sufficient inspection has been made by the city's representative to verify required thickness.

C. One extraction and gradation test per days' work, or one for every five hundred tons or fraction thereof, whichever is greater.

If the asphalt pavement fails to meet the allowable deviation for extraction or gradation tests, or shows a tendency under traffic loading to rut, tear, or distort, or in the opinion of the city's representative is tender or deficient in appearance, the asphalt pavement shall be cored and tested in accordance with AASHTO T-283-89 or ASTM D 4867-92 including Note 5.

Asphalt pavement so tested must possess seventy percent of the tensile strength ratio based on the approved Marshall mix design. Asphalt pavement not meeting this requirement requires removal.

The maximum allowable deviations from the approved Marshall mix design are:

Asphalt content	+/- 0.46%
2" (12.5 mm) and larger	+/- 6.3%
3/8" (9.5 mm)	+/- 5.9%
No. 4 (4.75 mm)	+/- 5.7%
No. 8 (2.36 mm)	+/- 4.8%
No. 16 (1.18 mm)	+/- 4.6%
No. 50 (.300 mm)	+/- 3.8%
No. 200 (.075 mm)	+/- 2.0%

#### **4.5.23.4 COMPACTION OF DENSE-GRADED ASPHALT PAVEMENT.**

- A. Acceptance of dense graded asphalt pavement shall be as follows:
- B. When the average of all density tests is not less than ninety-six (96) percent of the maximum laboratory density (Marshall) and when no single test is lower than ninety-two (92) percent of the Marshall.
- C. When the average of all density testing falls between ninety-three (93) percent to 95.9% of the Marshall with no test lower than ninety-two (92) percent of the Marshall, the asphalt pavement shall be tested to determine the percent of air voids. If the percent of air voids are between three to five (3-5) percent, the asphalt pavement will be considered acceptable. If the percent of air voids are between five to seven (5-7) percent, the asphalt pavement will require a slurry seal per these specifications.
- D. When the average of all density testing falls between ninety-one (91) percent of the Marshall and 92.9% of the Marshall with no single test below ninety (90) percent of the Marshall, the asphalt pavement shall ~~be~~ overlaid with a minimum of one-inch-thick asphalt pavement. Prior to the overlay, the existing asphalt next to the curb, gutter, cross gutter, etc. shall be milled one inch below the top edge of the concrete to provide a finished asphalt surface that is flush with or not more than .02 foot above the concrete gutter.
- E. Asphalt pavements with an average density less than ninety one percent of the Marshall, or with any single test less than ninety percent of the Marshall, shall be removed and replaced.

#### **4.5.23.5 OPEN-GRADED ASPHALT WEARING COURSE.**

If the extraction or gradation fails to meet the allowable deviation, the remaining sample material shall be remolded and tested in accordance with AASHTO T 283-89 or ASTM D 4867-92 including Note 5. The open-graded asphalt pavement must possess seventy percent of the tensile strength ratio based on the approved mix design. Open-graded asphalt not meeting this requirement requires removal.

The allowable maximum deviations from the approved Marshall mix design shall be as follows:

Asphalt content	+/- 0.46%
2" (12.5 mm)	+/- 6.3%
3/8" (9.5 mm)	+/- 5.9%
No. 4 (4.75 mm)	+/- 5.7%
No. 8 (2.36 mm)	+/- 4.8%
No. 200 (.075 mm)	+/- 2.0%

#### **4.5.23.6 ASPHALT PAVEMENT SURFACES.**

The completed surfacing shall be thoroughly compacted, smooth, and free from ruts, humps, depressions, rock pockets or slick spots. Any ridges, indentations or other objectionable marks left in the pavement's finished surface shall be corrected prior to acceptance.

The paving contractor shall provide adequate quality control during spreading and finishing procedures to meet or exceed the following longitudinal and transverse profiles:

- Longitudinal deviations shall not exceed 0.025 foot in 25 feet when checked by a taut string line.
- Transverse deviations shall not exceed 0.01 foot in 10 feet when checked with a ten-foot straight edge.
- Longitudinal construction joint deviations shall not exceed 0.01 foot when checked with a ten-foot straight edge.
- The completed pavement surfaces shall be constructed to the required grades and cross sections. When pavement surfaces contact concrete structures such as drainage structures, curbs & gutters, utility vaults, or manholes, the pavement surfaces shall be flush with or above the concrete structures by not more than 0.02 foot.
- All deviations exceeding the specified profile tolerances shall be corrected prior to final rolling.

**4.6 BITUMINOUS SEAL COAT (CHIP SEAL).** Bituminous surface treatments (chip seals) shall be applied to the road surface only when required or approved by the city representative. The bituminous surface treatment shall consist of an application of bitumen covered with mineral aggregate and rolled to a smooth surface presenting an even texture. The materials used in the application of the bituminous surface treatment shall be bituminous mineral, and mineral aggregate, as specified below.

**4.6.1 MATERIAL SPECIFICATIONS.**

**4.6.1.1 BITUMINOUS MATERIAL.** The bituminous material shall be cationic emulsified asphalt with a natural latex rubber material (type LMCRS-2H) and shall conform to the following requirements:

**TABLE 4.18  
BITUMINOUS MATERIAL**

TEST	SPECIFICATION	PARAMETERS
Viscosity @ 122E F. Sieve Settlement, 5 days Demulsibility Storage Stability (1 day test) Ash Content	AASHTO T-59 AASHTO T-59 AASHTO T-59 AASHTO T-59 AASHTO T-59 ASTM D3723	100-300 sec. 0.3% max. 5% max. 40% min. 1% max. 0.2% max.
Tests on Residue by Drying: Percent Residue Penetration @ 77E F., (100 g., 5 sec.) Ductility @ 77E F., (5 cm./min.) Torsional Recovery	NV 756 AASHTO T-49 AASHTO T-51 NV 756	65% min. 40-150 mm. 40 cm. min. 18% min.
Particle Charge	AASHTO T-59	POSITIVE

**4.6.1.2 AGGREGATE (CHIPS).** Mineral aggregate shall consist of crushed stone or crushed gravel, free from adherent films of clay or dust, and shall be of such nature that a thorough coating of the bituminous material used in the work will not strip off upon contact with water.

The gravel or rock shall have a percent of wear not greater than thirty when tested by the Los Angeles Abrasion Test (AASHTO T-9 ASTM C 131). Chips shall be cubical or pyramidal in shape with at least ninety-five (95) percent fractured faces. The crushed aggregate shall have a weighted percent of loss not exceeding ten percent by weight when subjected to five cycles of sodium sulfate and tested in accordance with AASHTO Designation T-104.

Stripping tests of the mineral aggregate which the Contractor proposes to use shall be furnished to the city’s representative before crushing operations

begin. During aggregate crushing, additional stripping tests shall be furnished to the city's representative upon request. No stripping test shall show a percent stripping greater than ten for LMCRS-2H asphalt. The chip shall be electrically compatible to the asphalt emulsion used.

The crushed aggregate shall conform to the gradation requirements shown in following table.

**TABLE 4.19  
GRADATION OF AGGREGATE FOR CHIP SEAL COATS**

SIEVE SIZE	PERCENT BY WEIGHT PASSING (Ideal)	IDEAL GRADATION TOLERANCE (Percent)
1/2 Inch	100	0
3/8 Inch	95	+/- 5
No. 4	15-10	+/- 5
No. 8	2	+/- 2
No. 200	0.5	+/- 0.5

The initial mineral aggregate used to produce chips shall be retained on a one-inch sieve prior to being crushed to the gradation specified.

**4.6.2 AGGREGATE QUALITY CONTROL.** Prior to delivery to the project site the designated wear test, stripping test, sodium sulfate test, fracture face count, and gradation tests shall be performed on the crushed aggregate. Each time a source changes said tests will be repeated.

All aggregate (chips) shall be tested for compliance with the gradation and fracture face count during the production of the chips. There shall be no less than one test performed for every five hundred tons of material produced or one day's production, whichever is less. One gradation test and fracture face count test shall be defined as the average results of tests taken on three different samples taken at one time.

All material produced shall be stockpiled in designated stockpile site(s).

When chips are delivered to the project stockpile site there shall be one gradation test conducted for every five hundred tons of material. If the gradation test requirements are not met, the city's representative may require that the failed material be removed from the stockpile. Chips shall be out of specification if one test (as defined herein above) fails.

The city's representative will not accept any chips which do not meet all the designated specifications. No reduction in pay or other remedial terms will be

allowed or negotiated.

In addition to the random acceptance samples taken at the stockpile, the city's representative may sample the aggregate from any portion of stockpile which exhibits a non-uniform appearance.

The Contractor shall take immediate steps to bring the aggregate into specifications when test results show any deviation from the established maximum or minimum values for any sieve as shown in Table 4.11 of these specifications.

At designated stockpile site(s), the Contractor may be required to push up the unloaded aggregate into piles suitable for loading into the delivery dump trucks.

Extreme care shall be taken so as not to mix any of the crushed aggregate with the underlying material at the stockpile or the crushing site. If there is contamination of the chip seal aggregate with foreign material, as determined by the city's representative, or by tests conducted, the contaminated section of materials shall be immediately removed from the stockpile or crushing area and properly disposed of. All contaminated material removed from the stockpile, or crushing area, shall be replaced with aggregate which meets the requirements of these specifications.

All testing required by the city's representative, or by the plans and specifications, shall be performed by an independent testing laboratory. The Contractor shall do everything in his power to ensure that the city's representative has full access to the testing procedure and shall deliver to the city's representative all results of tests run. The Contractor shall not proceed with subsequent construction until certified copies of appropriate tests are delivered to the City's Representative. Any materials not properly tested shall be subject to rejection and removal.

**4.6.3 EQUIPMENT.** All tools, equipment and machines used in the performance of the work shall be subject to the approval of the city's representative and shall be available at all times.

**4.6.3.1 ASPHALT DISTRIBUTOR.** The asphalt distributor shall be equipped with a calibrated dipstick marked in gallons per inch of length, and an accurate thermometer and speedometer. The distributor shall also be capable of maintaining proper pump pressure to always ensure a uniform distribution of liquid asphalt emulsion. The pump shall be able to maintain the correct pump speed, or pressure, without either atomizing the asphalt or distorting the spray fan. However, the pump shall be able to maintain a pressure which shall be sufficient to prevent streaking from a non-uniform discharge of material from the individual nozzles.

The distributor shall be equipped with a rear-mounted spray bar capable of covering widths of six to fifteen feet in a single pass. The distributor tank shall be well insulated and be equipped with one or more heaters capable of bringing the asphalt emulsion to spray application temperature. The tank shall

have a full circulating system which shall include the spray bar unit. The truck shall also be equipped with a hand-spray for applying the asphalt emulsion to areas that cannot be reached with the spray bar.

The distributor shall be equipped with a computer which will automatically determine the discharge based on the nozzle size, the truck speeds for various application rates, and the corrections for temperature-viscosity variations.

**4.6.3.2 AGGREGATE SPREADER.** The spreader shall be a self-propelled Flarity chip spreader, or equal, capable of uniformly spreading aggregate at varying application rates as required. The spreader shall be equipped with a tachometer and/or a speedometer to ensure the maintenance of a uniform spreader speed. The aggregate spreader shall also be equipped with a device and so operated that the coarse particles of the screening shall be deposited on the bituminous binder before the finer particles.

**4.6.3.3 ROLLERS.** The Contractor shall provide at least two self-propelled, smooth-tread, pneumatic tired rollers on the job during the chipping operations. Each roller shall weigh at least ten tons and have staggered (offset) front and rear tires to obtain a uniformly rolled pass. Tire pressure in all tires shall be uniform and inflated to eighty psi. No steel wheel rollers shall be used to roll the chip seal surface treatments. Rolling speed shall not exceed ten miles per hour.

**4.6.3.4 DUMP TRUCKS.** The Contractor shall provide sufficient ten-wheel dump trucks during the chip sealing operations to ensure that the project can proceed without interruption. FREQUENT STOPS AND STARTS DURING THE CHIP SEAL OPERATION WILL NOT BE PERMITTED.

**4.6.3.5 FRONT END LOADERS.** The Contractor shall have on hand at least one front end loader to load the aggregate into the dump trucks from the aggregate stockpile(s). The loaders shall have at least a two-and-one-half yard capacity bucket.

**4.6.3.6 POWER BROOMS.** The Contractor shall provide at least one self-propelled rotary power broom or sweeper at the job site and shall use said sweeper (supplemented with hand brooms as necessary) as required, to sweep the excess aggregate on the edge of each pass which will be in contact with the next pass so that there will be no buildup of aggregate at the seams or joints between passes. The broomed aggregate shall be swept onto the freshly laid course.

**4.6.4 BITUMINOUS CHIP SEAL CONSTRUCTION METHODS.** The methods employed in installing bituminous chip seal(s) shall include, but are not limited to, the following:

**4.6.4.1 SURFACE PREPARATION.** All dust, dirt, tracked on clay and foreign material shall be removed from the surfaces to be sealed by sweeping the

surface with power brooms, hand brooms, power blowers, or by flushing it with water or a combination of the above. All patching, crack filling and drainage improvements required by the city's representative shall be completed prior to the commencement of the surface treatment application. After the cleaning operation has been completed, and prior to the application of the surface treatment, the area to be treated will be inspected by the city's representative to determine its fitness for receiving the surface treatment.

All sewer manhole lids, water valve covers, and survey monument covers shall be protected from the application of the seal coat by placing building paper over the lids (cut to the exact dimensions of the lids) prior to the application of the seal coat. At the completion of the sealing operations, all protective coverings shall be removed from said survey monument covers, manhole lids, valve covers.

At the edges of all passes which will form longitudinal joints in the surface treatment (chip seal) the edge of the pass shall be swept clean of all chips for from four to six inches back from the edge prior to the application of the adjacent pass to allow for overlap without chip buildup (humps) in the previous pass. Building paper shall be laid on all cross gutters (concrete waterways) to prevent the chip seal from being applied to said gutters. The Contractor shall place building paper at the beginning of all chip passes. Immediately after the chip application, the building paper shall be removed and destroyed.

**4.6.4.2 ASPHALT APPLICATION.** Application of the bituminous material shall not be permitted until the loaded aggregate trucks, rollers, and chip-spreader are in place and ready to apply, and roll, the cover aggregate. No surface will be chip sealed until authorization to do so has been obtained from the city's representative. The asphalt material shall be applied at 0.32 to 0.40 gallons per square yard or as determined by the city's representative and at a temperature between 125 degrees to 185 degrees Fahrenheit. The exact temperature used to apply the bituminous material shall be determined by the city's representative.

The bituminous material shall be applied by an asphalt distributor, as described above, so that uniform distribution in the quantities specified is obtained over all points of the surface to be treated. All lightly coated areas and spots missed by the distributor shall be properly treated with bituminous material applied by hand. No more asphalt shall be applied than can be covered with aggregate in sixty seconds or less. Distances between the distributor and chip-spreader shall be as close as possible, but in no case shall the chip-spreader be greater than fifty feet behind the distributor during the chipping operations.

**4.6.4.3 AGGREGATE SPREADING.** Immediately following the application of the bituminous material, the aggregate shall be evenly spread over the surface at a uniform quantity of twenty-five to thirty (25-30) pounds per square yard of



surface area. Upon commencement of the work, and during its progress, the individual quantities of bitumen and aggregate may be varied to meet specific field conditions, as directed by the city's representative. An adequate supply of aggregate shall be available on the job site to permit continual spreading operations. Aggregate shall be damp (not wet) prior to being spread on the surface. The aggregate shall be spread by using a self-propelled spreader machine (Flarity or equal). The aggregate shall be spread evenly by hand on all areas missed by the aggregate spreader. Back-spotting or sprinkling of additional aggregate over the areas having insufficient cover shall be done by hand and shall be continued during the operations whenever necessary.

As the distributor moves forward to spray the asphalt, the aggregate spreader shall start right behind it, spreading the damp chips uniformly and at the specified rate. The asphalt distributor shall travel at the same rate of speed as the chip spreader and in no case shall the two machines be separated by more than fifty feet during the sealing process. Operating the chip spreader at speeds which cause the chips to roll over after striking the bituminous-covered surface will not be permitted.

Excess aggregate deposited in localized areas shall be immediately removed with square-end shovels, and in areas where application is insufficient, additional aggregate shall be added by hand prior to the time the asphalt "breaks".

**4.6.4.4 AGGREGATE COMPACTION.** The treated surface shall be rolled with rubber-tired rollers immediately after the distribution of the cover aggregate, and rolling shall continue until the aggregate is properly seated in the binder. Rollers shall proceed in the longitudinal direction, working across the treated surface until the entire width and length of the treated surface has been rolled at least four times. All rolling shall be completed within one hour after the application of the cover aggregate. Rollers and gravel trucks shall not be operated at speeds great enough to kick up chips, and in no case shall rollers be operated above ten miles per hour. In all places not accessible to the rollers, the aggregate shall be adequately compacted with pneumatic type hand tampers. Any aggregate that becomes coated or mixed with dirt or any other foreign material shall be removed, replaced with clean aggregate over a newly sprayed surface, and then re-rolled as directed by the city's representative.

Bituminous material and chips shall not be spread more than one hundred feet ahead of completion of initial rolling operations.

No aggregate will be allowed to be swept into the gutters, onto the sidewalks, or thrown onto private property. The Contractor shall be responsible for the cleanup of all aggregate swept into these areas.

Prior to placing the second chip seal course on streets designated for double chip seals, the first course shall be thoroughly rolled to set the chips, then no less than 24 hours later the excess chips shall be removed. Upon removal of

the excess chips, the second course may be applied.

**4.6.4.5. LOOSE AGGREGATE REMOVAL.** Upon completion of rolling, traffic will be allowed to use the streets at a speed not to exceed fifteen miles per hour for a period of not less than twenty-four hours. After the chips are set in the bituminous binder, but not earlier than the following day, or as directed by city's representative, loose chips on the surface of the road shall be broomed and removed in such a manner that the aggregate set in the binder will not be displaced. Excessive brooming will not be permitted. At the end of seven days, any excess chips shall be removed in such a manner that the aggregate set in the binder will not be displaced. Excessive rolling or brooming will not be permitted.

**4.6.4.6. SANDING.** After the surface has been opened to traffic, any excess bituminous material that comes to the surface (bleeds) shall be immediately covered with CLEAN SAND. The Contractor shall be required to have sufficient CLEAN sand (NOT DIRT) on hand or available to immediately sand any bleeding spots when requested by the city's representative. Sanding shall be accomplished by evenly spreading the sand over the affected area and then hand brooming the sand to a smooth even surface with no bumps, ruts, depressions, or irregularities visible.

**4.6.4.7. APPEARANCE.** The completed chip sealed surface shall present a uniform appearance and shall be thoroughly rolled and compacted and free from ruts, humps, depressions, or irregularities due to an uneven distribution of bituminous binder or aggregate. In the event the surface presents an unacceptable appearance, as determined by the city's representative, the Contractor shall repair unacceptable areas in accordance with the city representative's directions.

**4.6.4.8. WEATHER LIMITATIONS.** Chip seal treatments shall be placed only when the air temperature in the shade is above 75 degrees Fahrenheit. The chip seal shall not be placed when the temperature of the road surface is below 70 degrees Fahrenheit, above 120 degrees Fahrenheit, during rainy weather, when the surface is wet or during other unfavorable weather conditions as determined by the city's representative.

**4.7 ASPHALT EMULSION SEAL COAT (SLURRY SEAL).** This sub-section covers the requirements for the application of slurry seal coats on existing road surfaces. The slurry seal surface treatment shall consist of a mixture of emulsified asphalt, mineral aggregate, mineral filler, set control additive, and water. The slurry shall be properly proportioned, mixed, and spread evenly on a prepared surface in accordance with these specifications, or as directed by the city's representative. When cured, the slurry shall have a homogeneous appearance, fill all cracks, adhere firmly to the road surface, and have a skid resistant texture.

## 4.7.1 MATERIAL SPECIFICATIONS.

**4.7.1.1. ASPHALT EMULSION.** The asphalt emulsion shall conform to the specifications outlined in Tables 4.12, 4.13 and 4.14. Either cationic or anionic emulsion may be used, whichever is best suited to the aggregate and job conditions to be encountered, as determined by compatibility tests and procedures as specified in the latest edition of the ISSA Technical Bulletin #115.

**4.7.1.2. AGGREGATE.** The mineral aggregate shall consist of angular sand, or crushed stone, that is free from dirt, organic matter, clay balls, adherent films of clay, dust, or other objectionable matter. When tested according to AASHTO T-176, the aggregate shall have a sand equivalent of not less than forty-five (45), and the aggregate shall be non-plastic. When tested according to AASHTO T-104, the aggregate shall show a loss of not more than fifteen (15) percent, and when tested according to AASHTO T-96, the aggregate shall show a loss of not more than thirty-five (35) percent.

The combined mineral aggregate shall conform to the requirements of type II or type III slurry as outlined in Table 4.15.

**4.7.1.3. FILLER.** The mineral filler shall conform to the requirements of AASHTO M-16 and shall be used to improve the gradation of the aggregate, to provide improved stability and workability of the slurry, and to increase the durability of the cured slurry.

**4.7.1.4. SET CONTROL ADDITIVE.** To control the setting time of the slurry mixture, an additive shall be added which will retard the set when a cationic emulsion is used or accelerate the set when an anionic emulsion is used. The set control additive shall be aluminum sulfate or Portland Cement Type I/II and shall be added to the slurry mix by an approved method that will assure uniform distribution and proper control. The exact amount shall be determined by conditions in the field and as directed by city's representative.

**TABLE 4.20  
SLURRY SEAL TEST SPECIFICATIONS  
TESTS OF EMULSIONS**

TESTS	TEST METHOD	TYPE OF EMULSION	
		ANIONIC	CATIONIC
	ASTM	ANIONIC	CATIONIC
		Quick Setting	Quick Setting
		QS-1H	CQS-1H CQS-1H-LM
Particle Charge Test	D244	Negative	Positive
Viscosity, 60 ml., @ 77° F., 5 seconds	D244	15 min. to 100 max.	
Residue by distillation	D244	60 percent by weight, minimum	
Settlement After Five Days (%)	D244	5 percent maximum	
Sieve Test Wt., (%)	D244	0.10 maximum	
Cement Mixing Test	D244, 32-36	2 % Maximum	Not Applicable

**TABLE 4.21  
SLURRY SEAL TEST SPECIFICATIONS  
TESTS OF RESIDUE**

TESTS	TEST METHOD	TYPE OF EMULSION	
		ANIONIC	CATIONIC
	ASTM	ANIONIC	CATIONIC
		Quick Setting	Quick Setting
		QS-1H	CQS-1H CQS-1H-LM
Penetration 100 gm. @ 77° F for 5 seconds	D244	40 to 90 mm	40 to 90 mm
Solubility in Trichloroethylene	D2042 4d	97.5 percent, minimum	
Ductility, 5 cm/mm @	D244	40 cm., minimum	

**TABLE 4.22  
SLURRY SEAL TEST SPECIFICATIONS  
TESTS ON SLURRY SEAL JOB MIXTURE**

TESTS	TEST METHOD		TYPE OF EMULSION	
	AASHTO	ASTM	ANIONIC	CATIONIC
			Quick Setting	Quick Setting
			QS-1H	CQS-1H CQS-1H-LM
Mixing Time @ 77° F (ISSA TB #102)	---	---	120 seconds minimum	120 seconds minimum
Set Time Tests (30 minutes) Blotter Test (ISSA TB #102)	---	---	No Brown Stain	No Brown Stain
Displacement Test	---	---	No Displacement	No Displacement
Water Resistance Test @ 30 Min. (ISSA TB #102)	---	---	No Discoloration	No Discoloration
Wet Stripping Test, Coating (ISSA TB #114)	---	---	90 percent, minimum	
System Compatibility	C	C	Compatible	

**TABLE 4.23  
SLURRY MIXTURE GRADATION**

Type of Slurry	II	III
General Usage	General seal, medium textured surfaces; second course slurry	First and/or second application of two-course slurry; highly textured surfaces
Sieve Size (USA Standard Series)	PERCENT PASSING	
3/8 inch	100	100
No. 4	90-100	70-90
No. 8	65-90	45-70
No. 16	45-70	28-50
No. 30	30-50	19-34
No. 50	18-30	12-25
No. 100	10-21	7-18
No. 200	5-15	5-15

**4.7.1.5. WATER.** Water for the slurry mixture shall be potable and free from harmful soluble salts.

#### **4.7.2 MATERIAL QUALITY CONTROL.**

**4.7.2.1. SAMPLING AND TESTING.** Prior to the commencement of sealing operations, sources of all materials shall be selected and tested in accordance with the appropriate test requirements. Additional samples of materials shall be furnished as directed by the City's representative during the progress of the work. The Contractor's proposed job mix design shall be approved by the city's representative prior to the commencement of construction.

**4.7.2.2. JOB MIX DESIGN.** No slurry mixture shall be placed until a mix design submitted by the Contractor has been approved by the city's representative. The exact proportions of asphalt emulsion, aggregate, mineral filler, and water to be used in the preparation of the slurry seal shall be determined by an approved testing laboratory experienced in slurry mix design procedures.

The residual asphalt content of the mix shall be from 7.5 to 13.5 percent of the dry aggregate for type II slurry seal or 6.5 to 12 percent of the dry aggregate for type III slurry seal.

The slurry shall be a homogeneous mixture, sufficiently stable during the entire mixing-spreading period so that the emulsion will not break. There shall be no segregation of the fines from the coarser aggregate, and the liquid portion of the mix shall not float to the surface. If it is established that a satisfactory mixture meeting the requirements specified herein cannot be produced from the materials furnished, the materials shall be rejected, and the Contractor shall submit new samples.

The wet track abrasion test shall not exceed a maximum wear loss of seventy-~~ten~~grams per square foot.

**4.7.3 EQUIPMENT.** The equipment, tools, and machines required for the performance of the work shall be subject to the approval of the city's representative and shall be always maintained in a satisfactory working condition.

**4.7.3.1. SLURRY MIXING MACHINE.** The slurry mixing machine shall be a continuous flow mixing unit, capable of delivering accurately predetermined proportions of aggregate, water, and asphalt emulsion to a revolving spiraled multi-blade mixer tank, and of discharging the thoroughly mixed product on a continuous basis. The aggregate shall be pre-wetted immediately prior to mixing with the emulsion. The mixing unit shall be capable of thoroughly blending all ingredients together without violent action. The mixing machine shall be equipped with an approved fines feeder with an accurate metering device or method of introducing a predetermined proportion of mineral filler

into the mixer as the aggregate is fed into the mixer. The fines feeder shall be used when mineral filler is part of the aggregate blend. The mixing machine shall be equipped with a water pressure system and fog-type spray-bar adequate for completely fogging the surface to be sealed with up to 0.05 gallons of water per square yard, immediately ahead of the spreading equipment. The machine shall be capable of mixing materials at pre-set proportions regardless of the speed of the machine and without changing machine settings.

**4.7.3.2. SLURRY SPREADER.** Attached to the mixing machine shall be a mechanical-type squeegee distributor, having a rubber-like material in contact with the surface to be sealed to prevent unwanted egress of slurry. An appropriate mechanical device for lateral distribution of the slurry shall be operated within the spreader box. There shall also be a steering device and a flexible strike-off. The spreader box shall be adjustable to various widths from eight (8) to twelve (12) feet. The box shall be kept clean with no extensive build-up of asphalt and aggregate on the box. A burlap drag of at least one foot in width shall be attached to the back of the spreader box to smooth out irregularities in the slurry surface.

**4.7.3.3. SURFACE CLEANING EQUIPMENT.** Power brooms, power blowers, vacuums, air compressors, water flushing equipment, and hand brooms suitable for cleaning the road surface and cracks therein may be used for surface cleaning.

**4.7.3.4. AUXILIARY EQUIPMENT.** Hand squeegees, burlap mops, shovels and other equipment shall be provided as necessary to perform the work.

#### **4.7.4 ASPHALT EMULSION SLURRY CONSTRUCTION METHODS.**

**4.7.4.1. RESIDENT NOTIFICATION.** The Contractor shall be responsible for notifying all affected residents of pending cleaning and/or sealing operations on streets abutting their properties. Notification shall be no more than forty-eight hours, nor less than twenty-four hours, in advance of said cleaning/sealing operations. If there should be any change in scheduling for a particular day's production, the Contractor shall be required to notify all the residents affected by the schedule change no later than one hour after the schedule change has been determined.

**4.7.4.2. VEHICLE REMOVAL.** The Contractor shall be responsible for the removal of all vehicles from the streets to be cleaned and shall endeavor to notify the owners of the vehicles to move them prior to his cleaning operations. In the event owners of said vehicles cannot be located, the

Contractor shall have them towed from the construction zone prior to cleaning and shall be responsible for all costs incurred for said towing.

**4.7.4.3. PREPARATION OF SURFACE.** If patching or surface

smoothing is required to prepare the street surface for the slurry seal, the Contractor shall patch the street surface with hot mix asphalt prior to the application of the slurry sealing. Prior to the application of the slurry seal, the city's representative shall give approval that the surfaces have been properly prepared. No slurry seal material will be laid without the city representative's approval.

**4.7.4.4. CLEANING STREETS.** Prior to the commencement of Slurry Seal operations, the Contractor shall thoroughly clean and remove all mud spots and loose or objectionable material from the existing pavement surface. Any standard cleaning method will be acceptable, except that water flushing will not be permitted in areas where poor drainage conditions on the road or at the sides of the road are present, as determined by the city's representative.

Traffic paint on the surface to be treated that is not tightly bonded to the surface shall be removed.

Areas impregnated with grease, oil, or fuel shall be scrubbed with industrial-type detergent and flushed thoroughly to remove all traces of detergent and oil.

After the cleaning operations have been completed, and prior to the application of the surface treatment, the area to be treated will be inspected by the City's Representative to determine its fitness for receiving the surface treatment. No surface shall be slurry sealed until authorization to do so has been obtained from the city's representative.

**4.7.4.5. SEWER MANHOLE LIDS AND WATER VALVE COVERS.** Prior to the application of the seal coat, all sewer manhole lids, survey monument lids, storm drain manhole lids and water valve covers shall be protected from the application of the slurry seal coat by placing building paper over the lids (cut to the exact dimensions of the frames to prevent the slurry seal from entering the seam between the frame and lid). At the completion of the sealing operations, the Contractor shall remove all building paper protectors placed on said lids and covers.

**4.7.4.6. TEST SECTION.** Prior to full production, the Contractor shall place a test section of at least sixty square yards in an area designated by the city's representative. The test section shall be placed using the same equipment, methods, and mix as will be used on the job.

If the test section should prove to be unsatisfactory, necessary adjustments to the mix design, equipment, and/or placement methods shall be made. Additional test sections, as required, shall be placed, and evaluated for compliance with the specifications. If the test section does not conform to the specification requirements, the defective slurry seal shall be removed. Full production shall not begin without approval of the city's representative.



**4.7.4.7. WATER FOG.** Immediately prior to application of the slurry seal, the surface of the pavement shall be moistened with a fog spray of water, applied at the rate of 0.02 to 0.05 gallon per square yard from the spray bar attached to the slurry seal machine. No free water shall pond on the surface of the pavement following the fog spray. The rate of application of the fog spray shall be adjusted during the day to suit pavement temperatures, surface texture, humidity, and dryness of the pavement surface.

**4.7.4.8. PREPARATION OF SLURRY.** The slurry seal shall be mixed and applied with a slurry machine as outlined below. The amount and type of asphalt emulsion to be blended with aggregate shall be determined by the laboratory mix design. A minimum amount of water, added as specified by the city's representative, shall be used as necessary, to obtain a workable and homogeneous mixture. The slurry mixture shall be of proper consistency with no segregation when deposited on the surface of the pavement and no additional elements shall be added. The slurry mixture shall show no signs of uncoated aggregate, or premature breaking of emulsion, when applied to the pavement surface. Total time of mixing shall not exceed four minutes.

**4.7.4.9. APPLICATION OF SLURRY.** Sufficient quantities of the slurry seal mixture shall be fed into the spreader box such that a uniform and complete coverage of the pavement is obtained. The slurry seal machine shall be operated at such a speed that the amount of slurry in the spreader box shall remain essentially constant. The slurry seal shall be placed at a rate within the following general limits: Type II slurry - 10-15 #/yd.<sup>2</sup>; Type II slurry - 15-20 #/yd.<sup>2</sup>. The finished slurry thickness shall not be less than 3/8 of an inch. No build-up of the cured slurry seal mix shall be allowed to collect in the spreader box. No streaks caused by oversized aggregate particles, or build-up of slurry mix on squeegees, shall be left on the finished surface.

If a uniform thickness cannot be met with one application due to irregularities in the pavement surface, multiple applications shall be made. Where multiple applications are required, as determined by the city's representative, each application shall be thoroughly cured prior to the application of the subsequent courses.

**4.7.4.10. HANDWORK.** Approved squeegees and mops shall be used to spread slurry in areas not accessible to the slurry spreader box. Care shall be exercised in leaving no unsightly appearance from handwork. When doing handwork in small areas, especially fill-in behind the slurry machine, the material shall be spread and mopped in the direction of the machine pass.

**4.7.4.11. JOINTS.** The longitudinal joints between adjacent lanes shall have no visible lap, pinholes, or uncovered areas. Thick spots caused by overlapping shall be smoothed immediately with hand squeegees before the emulsion breaks. Overlaps which occur at transverse joints shall also be smoothed before the emulsion breaks, so that a uniform surface is obtained

which contains no breaks or discontinuities.

**4.7.4.12. CURING.** Treated areas shall be allowed to cure until the treated pavement will not be damaged by traffic. The Contractor shall protect this area for the full curing period with suitable barricades or markers. Areas which are damaged before being opened to traffic shall be repaired by the Contractor.

**4.7.4.13. WEATHER LIMITATIONS.** The slurry seal shall not be applied when either atmospheric or pavement temperature is below 55 degrees, or above 100 degrees Fahrenheit, when raining or during periods of abnormally high relative humidity, or as determined by the city's representative.

**4.8 CONCRETE WORK.** This section defines the materials to be used and the requirements for mixing, placing, finishing, and curing all Portland cement concrete work.

**4.8.1. MATERIALS.** Concrete materials shall conform to the following requirements.

**4.8.1.1 PORTLAND CEMENT CONCRETE MATERIAL.** Concrete shall be composed of coarse aggregate, fine aggregate, Portland Cement and water, air entrainment and add mixtures and shall conform to the requirements of this section. A concrete mix design shall be prepared by the supplier, certified by an independent testing lab, and submitted to the city for review and approval prior to concrete being used in city projects.

A. **PORTLAND CEMENT.** ANSI/ASTM C 150, Type V, shall be used unless otherwise indicated, or approved by the City representative. Only one brand of cement shall be used throughout a project, unless otherwise approved by city's representative. Certified copies of the mill test for the cement shall be furnished upon request of the city's representative.

B. **AGGREGATE.** Except as otherwise specified herein, concrete aggregate shall conform to all applicable provisions of the latest revision of ASTM Standard Specification C 33.

B.1 **Fine Aggregate.** Fine aggregate shall consist of natural sand having clean, hard, durable, uncoated grains and shall conform to the requirements of these standards. Other inert materials with similar characteristics shall not be used unless approved by the city representative. The number of deleterious substances shall not exceed the following limits.

**TABLE 4.24  
FINE AGGREGATE**

<b>MATERIAL</b>	<b>PERCENT (By weight)</b>
Clay Lumps	1.00
Coal and lignite	0.50
Material passing No. 200 sieve	3.00
Other deleterious substances such as shale, alkali, mica, coated grains, soft and flaky particles, etc.	3.00
Gypsum	1.00

The combined sum of the percentage of all deleterious substances in fine aggregate listed above shall not exceed three percent by weight. Fine aggregate shall be well graded and shall range in size from fine to coarse within the following percentages by weight:

**TABLE 4.25  
FINE AGGREGATE GRADATION REQUIREMENTS**

<b>SIEVE SIZE</b>	<b>PERCENT PASSING (by weight)</b>
3/8 inch	100
No. 4	95-100
No. 8	80-100
No. 16	50-85
No. 30	25-60
No. 50	10-30
No. 100	2-10

**B.2 Coarse Aggregate.** Coarse aggregate shall consist of crushed or natural stone, gravel, slag or other approved inert material with similar characteristics or combination thereof, having clean, hard, durable, uncoated particles free from deleterious matter. Deleterious substances shall not be present in the aggregate more than the following limits:

**TABLE 4.26  
COARSE AGGREGATE**

<b>MATERIAL</b>	<b>PERCENT (By weight)</b>
Soft fragments	2.00
Coal and lignite	0.30
Clay Lumps	0.25
Material passing No. 200 sieve	1.00
Other deleterious substances such as shale, alkali, mica, coated grains, soft and flaky particles, etc.	3.00
Gypsum	1.00

The combined sum of the percentages of deleterious substances (in both course and fine aggregate), shall not exceed five percent, by weight.

Coarse aggregate shall be rejected if it fails to meet the following test requirements:

- a. Los Angeles Abrasion Test. If the percent of loss by weight exceeds ten percent at one hundred revolutions, or forty percent at five hundred revolutions.
- b. Sodium Sulfate Test for Soundness. If the weighted average loss after five cycles is more than twelve percent by weight.
- c. Gradation. Coarse aggregate shall be graded by weights as follows:

**TABLE 4.27  
COARSE AGGREGATE GRADATION REQUIREMENTS**

<b>SIEVE SIZE</b>	<b>PERCENT PASSING (by weight)</b>
1 inch	100
3/4 inch	90-100
3/8 inch	20-55
No. 4	0-10
No. 8	0-5

d. Aggregate Size. The maximum size of the aggregate shall not be larger than one-fifth of the narrowest dimension between forms within which the

concrete is to be encased, and in no case larger than three-fourths of the minimum clear spacing between reinforcing bars or between reinforcing bars and forms. For non-reinforced concrete slabs, the maximum size of aggregates shall not be larger than one-fourth the slab thickness.

C. **WATER.** Sufficient potable water shall be added to the mix to produce concrete with the minimum practical slump, the slump shall not be greater than four inches. However, a higher slump may be allowed with plasticizers, providing there is no loss of strength or durability and prior approval for use is obtained from the city's representative.

The maximum permissible water-cement ratio (including free moisture in the aggregate) shall be five gallons per bag of cement (0.44) for Class A and five and three-quarter gallons per bag of cement (0.51) for Class C concrete.

D. **ENTRAINING AGENT.** An air-entraining agent shall be used in all concrete exposed to the weather. The agent shall conform to ASTM designation C 260. Air content for air-entrained concrete shall be five percent by volume (plus or minus one percent). The air-entraining agent shall be added as a liquid to the mixing water by means of mechanical equipment capable of accurate measurement and control.

E. **ADMIXTURES.**

E.1 Pozzolan. When authorized by the city representative, pozzolan conforming to the requirements of ASTM C 618 Class F may be added to the concrete mix as outlined below:

A. Pozzolan may be used as a replacement to the required Portland Cement content provided no other supplemental specification prevents its use. The maximum percentage of Portland Cement replacement on a weight basis is 15 percent.

B. Pozzolan/cement replacement ratio is 1.25 to 1 (pozzolan/cement).

C. Water/cement ratio is established before Portland Cement is replaced with pozzolan.

D. Loss of ignition of pozzolan is less than 1 percent.

E. Trial batches for each aggregate source and concrete class have been run for each mix design.

F. All other requirements and references to testing procedures and specifications of Section 4.8 Concrete Work shall apply.

Pozzolan shall be sampled and tested as prescribed in ASTM C 618 and ASTM C 311. The Concrete Supplier shall obtain and deliver to the city's representative a certification of compliance signed by the pozzolan supplier identifying the pozzolan and stating that the pozzolan delivered to the batching site complies with applicable specifications.

Pozzolan material shall be handled and stored in the same manner as Portland Cement. When facilities for handling bulk pozzolan are not

available, the pozzolan shall be delivered in original unopened sacks bearing the name and brand of supplier, the type and source of the pozzolan, and the weight contained in each sack plainly marked thereon.

Different brands or types of pozzolan shall not be mixed unless written permission has first been obtained from the Owner's Representative. All pozzolan used in the manufacture of concrete for any individual structure shall be of the same type, and from the same source unless otherwise approved by the city's representative.

**COMPLIANCE ANALYSIS.** During concrete testing, the City may require, at random, additional concrete cylinders for the purpose of performing a Petrographic Examination in accordance with ASTM C 856.

The Petrographic Examination may be initiated when compressive strength tests show inconsistencies, when batch tickets show indications that material is batched which is not in accordance with approved mix designs, or when there are other indicators that the concrete may not meet Standards.

The Petrographic Examination will be performed by a Certified Testing Laboratory qualified to perform such testing. If the sampled concrete is not in compliance with these standards, the supplier of the concrete will be required to pay for the Petrographic Examination and will no longer be allowed to supply concrete for use in any improvements for which City Standards apply until acceptable adjustments are made. If the sampled concrete is found to be following these standards, the city will pay the cost for the Petrographic Examination. Additional testing may be required by the City Engineer, at the supplier's expense, to determine the extent of the non-compliant concrete. All work on a project, affected by the non-compliant concrete, will be suspended until the non-compliant concrete work is brought into compliance.

The Petrographic Examination will determine the quantity of cementitious matrix including mineral admixture (pozzolan/fly ash) in the mix, proportions of the mix, and other properties of the sampled concrete to verify compliance with the approved mix design. The acceptability of the concrete represented by the examination shall be established by comparing the proportions determined by the examination with those indicated on the batch tickets. When this comparison shows that the pozzolan proportions are within 2% +/- of the approved mix design, the admixture proportions will be in compliance. When comparisons of other proportions of the mix indicate that the concrete is not within acceptable allowable deviation limits, the concrete may be rejected even though the pozzolan proportion is acceptable.

The city may use the results of the Petrographic Examination, inspection records, observation of batch plant operation, compressive strength test

results, or any other pertinent information to determine compliance. If any portion of a project is found to be in non-compliance, additional testing shall be required to verify full compliance of all concrete within the project. If the City Engineer has reasonable cause, he may require removal and replacement of any concrete which has been found to be in non-compliance. (For the purpose of demonstrating the acceptability of this admixture specification, compressive strength alone shall not be considered as justification for acceptance.)

Repeated violations of these admixture standards may subject the offending concrete supplier to be prohibited from providing concrete that is used in public or private infrastructure improvements within the City of Santa Clara.

**E.2 Calcium Chloride.** Calcium Chloride shall not be added to any concrete mix. Non-chloride accelerators may be used upon approval of the City Engineer or designee.

**F. CONCRETE MIX.** For practical identification, concrete has been divided into classes. The basic requirements of class A and class C and the use for each is defined in Table 4.16.

**Submittals.** The following information should be available upon request of city representative with all concrete mix designs submitted for review and approval by the City as per subsection 4.8.1.1 Portland Cement Concrete Material.

- A. Test results on coarse and fine aggregates to verify compliance with applicable specifications.
- B. Trial batch test results and past history test information on proposed mix designs, which support compliance with the requirements for compressive strength, durability, etc. Performance curves used to verify 28-day, 56-day, and 90-day strengths must be submitted with trial batch tests or history information.
- C. Certification of compliance from the cement supplier, the pozzolan supplier, and the air-entraining agent supplier, stating that the material being delivered are in compliance with applicable specifications.
- D. All mix designs shall be certified by a Certified Testing Laboratory.

**G. BATCH PLANT TICKET.** All concrete produced and delivered to a job site within Santa Clara City, will be accompanied by a batch plant ticket. The ticket will state the time manufactured or batched and accurately show

all components used for that load or batch. Sufficient copies shall be provided for testing personnel and Santa Clara City representatives, if requested.

**TABLE 4.28  
CONCRETE MIX SPECIFICATIONS**

Class	Minimum Cement Content		Maximum Water Content** (gal./bag of cement)	Maximum Slump	Minimum 28-day Comp. Strength (psi)	Primary Use
	(Bags/ C.Y.)	(pounds/ C.Y.)				
A	6	564	5	4"  1-1/2"	4000***	Reinforced structural concrete; sidewalks; curbs & gutters; cross gutters; pavements; unreinforced footings
C	5	470	5.75	4"	3000	Minor non-structural items such as thrust blocks; anchors, mass concrete, etc.

\* For machine placement only.

\*\* Including free moisture in aggregate.

\*\*\* Or as specified by a structural engineer.

NOTE: Unless otherwise specifically designated by the city representative all concrete placed shall be Class "A", six-bag mix, with a minimum allowable compressive strength of 4000 p.s.i at the age of twenty-eight days.

**4.8.1.2 CONCRETE REINFORCING MATERIALS.** Concrete reinforcing materials shall conform to the following requirements.

**A. STEEL BARS.** All bar material used for reinforcement of concrete shall be hard grade deformed round steel conforming to the requirements of ASTM Designation A 615. All reinforcing steel shall be minimum grade sixty (60) unless approved otherwise by the city representative. All bars shall be deformed, round and have a net section equivalent to that of plain bar of equal nominal size. Only hard grades will be used. Twisted bars will not be accepted.

All rebar shall be clearly marked with identifying markings in accordance with industry standards.

All reinforcing steel, at the time concrete is placed, shall be free from flaws, cracks, rust, oil, dirt, paint, or other coatings that will destroy or reduce the bond.



**B. WIRE OR WIRE FABRIC REINFORCEMENT.** Welded wire fabric for concrete reinforcement shall conform to the requirements of ASTM A 185. Wire for concrete reinforcement shall conform to the requirements of the "Standard Specification for Cold Drawn Steel Wire for Concrete Reinforcement" ASTM A-82. All wire reinforcement, wire fabric, or expanded metal shall be of the type designated unless an alternate type is approved by the City representative.

**C. STEEL FIBER REINFORCEMENT.** Deformed steel fiber for concrete reinforcement shall conform to the requirements of ASTM A-820, type I, deformed fiber, except that the average tensile strength shall be not less than 150,000 psi.

**D. SYNTHETIC REINFORCING FIBERS.** Engineered synthetic reinforcing fibers shall be 100% polypropylene collated, fibrillated fibers. Fiber length, and amount per manufacturer's recommendations shall correspond with the concrete mixture (generally 1.5 pounds per cubic yard of concrete). Physical property of the fibers shall be as follows:

**TABLE  
4.29 SYNTHETIC REINFORCING  
FIBERS**

<b>Specific Gravity</b>	<b>0.91</b>
Modulus of elasticity	500,000 to 700,000 psi
Tensile strength	70,000 to 110,000 psi
Length	0.25 to 2.50 inches

The fiber manufacturer shall certify that all polypropylene fibers meet the physical properties and are specifically manufactured for use in concrete from virgin polypropylene, containing no reprocessed olefin materials. If the fiber manufacturer is other than the brand name listed on the literature and packaging, the certification must be from the original manufacturer of the fibers.

Fiber-mesh shall be added only at the concrete batch plant to assure uniform and complete dispersion of the collated-fibrillated fiber bundles into single monofilaments within the concrete.

**4.8.1.3 CURB, GUTTER, SIDEWALK AND BASE MATERIALS.** Concrete and base materials shall conform to the following requirements.

**A. GENERAL.** This subsection defines materials, practices, and designs to be used in the construction of all public curb, gutter, and sidewalk.

All curb, gutter and sidewalk shall consist of air-entrained Type V Portland

Cement Concrete and shall be constructed on a prepared subgrade in accordance with these specifications. All work shall conform to the lines and grades, thickness, and typical cross sections shown on the approved plans or established by the city's representative.

**B. SUBGRADE.** The subgrade shall be excavated and filled with suitable material, as specified in Section 4.3.2.3 of these standards. All soft, yielding and otherwise unsuitable material shall be removed and replaced with suitable materials as outlined above. Filled sections shall be compacted and extend to a minimum of one (1) foot outside the form lines according to Section 4.3.2.3 of these standards.

**C. GRAVEL BASE COURSE.** A gravel base course consisting of crushed road base gravel shall be placed under all curbs, gutters, driveways, waterways, sidewalks, and other miscellaneous flatwork. The gravel base material shall conform to the requirements contained in Section 4.5.7 of these specifications. Where the foundation material is found to be unstable, the Contractor shall furnish, and place sufficient additional gravel or other suitable material as directed by the city's representative to provide an adequate foundation upon which the concrete will be placed.

**4.8.2. CONSTRUCTION METHODS AND EQUIPMENT.** The methods employed in performing the work, all equipment, tools and machinery, and other appliances used in handling the materials and executing the work shall be the responsibility of the Contractor. The Contractor shall make such changes in the methods employed and, ~~it~~ ~~equipment~~ used as are necessary whenever the concrete being installed does not meet the specifications herein established. These methods shall include, but are not limited to the following:

**4.8.2.1 GENERAL CONCRETE PLACEMENT.** Generally, concrete shall be placed as follows.

**A. FORMS.** Forms shall be properly built and adequately braced to withstand the liquid weight of concrete being placed in the forms. All linings, studding, whaling, and bracing shall be such as to prevent bulging, spreading, loss of true alignment or displacement while placing and during setting of concrete.

**B. PREPARATIONS.** Prior to batching and placing concrete, all equipment for mixing and transporting the concrete shall be cleaned. All debris and ice shall be removed from the areas to be occupied by the concrete. All forms shall be oiled with a form-release agent. Masonry support or filler units that will be in contact with concrete shall be well drenched with water (except in freezing weather). Reinforcement shall be thoroughly cleaned of ice or other coatings. Water shall be removed from areas to receive concrete.

Reinforcement that has become too hot, due to sun exposure, in the opinion of the city representative, will be cooled with water prior to

concrete being placed.

When placing concrete on earth surfaces, the surfaces shall be free from frost, ice, mud, water, and other deleterious materials. When the subgrade is dry or pervious, it shall be sprayed with water prior to the placing of concrete or shall be covered with water-proof sheathing paper or a plastic membrane. No concrete shall be placed until the preparatory work (i.e., forms, reinforcement, etc.) has been inspected and approved by the city's representative.

**C. CONCRETE MIXING.** The concrete shall be mixed until there is a uniform distribution of the materials. Sufficient water shall be used in concrete in which reinforcement is to be imbedded, to produce a mixture which will flow sluggishly when worked and can be conveyed from the mixer to the forms without separation of the coarse aggregate from the mortar. In no case shall the quantity of water used be sufficient to cause the collection of a surplus in the forms.

Ready-mixed concrete shall be mixed and delivered in accordance with the requirements set forth in Specifications for Ready-Mixed Concrete (ASTM C-94). Concrete shall be delivered and deposited in its final position within sixty (60) minutes after the cement and water have been added to the mixture.

**D. DEPOSITING.** Concrete shall be deposited as nearly as practical in its final position to avoid segregation due to rehandling or flowing. Concrete placement shall be carried on at such a rate that the concrete is always plastic and flows readily into the corners of forms and around reinforcing bars. Concrete that has partially hardened or is contaminated by foreign material shall not be deposited in the work. Re-tempered concrete shall not be used.

Temperature of the mixed concrete shall be maintained between 60F and 90F at time of placement.

All concrete in structures shall be compacted by means of high-frequency internal vibrators of approved type and design during the operation of placing and shall be thoroughly worked around reinforcement and embedded fixtures and into the corners of the forms. Care must be taken not to overuse vibrators causing separation of cement and aggregates.

**E. FINISHING.** After the concrete for slabs has been brought to the established grade and screeded, it shall be worked with a magnesium float and then given a light "broom" finish. In no case shall dry cement or a mixture of dry cement and sand be sprinkled on the surface to absorb moisture or hasten hardening. Surface edges of all slabs shall be rounded to a radius of one quarter to one half (1/2) inch with standard concrete finishing tools. Additional water shall not be sprinkled on the surface to aid

finishing.

**F. CURING AND PROTECTION.** As soon as the concrete has hardened sufficiently, it shall be protected and cured in accordance with ACI Standards. The finished surface shall be kept moist for a minimum of seven days, or a chemical curing agent used to prevent the concrete from premature drying.

The freshly finished surface shall be protected from hot sun and drying winds until it can be sprinkled or covered as above specified. The concrete surface shall not be damaged or pitted by rain. The Contractor shall provide and use, when necessary, sufficient tarpaulins to completely cover all sections that have been placed within the preceding twelve (12) hours. The Contractor shall erect and maintain suitable barriers to protect the finished surface. Any section damaged from traffic, weather, people, or other causes occurring prior to its final acceptance, shall be repaired, or replaced by the Contractor in a manner satisfactory to the city's representative.

**G. WEATHER LIMITATIONS.** Concrete shall not be poured where the air temperature is lower than thirty-five (35<sup>0</sup>) degrees F. unless approved by the City's Representative. When there is likelihood of freezing during the curing period, the concrete shall be protected by means of an insulating covering to prevent freezing of the concrete for a period of not less than seven days after placing. Equipment for protecting the concrete from freezing shall be available at the job site prior to placing concrete. Care shall be exercised to protect edges and exposed corners from freezing. Cold weather placement shall generally follow the requirements of ACI 306.1

Hot weather placement shall generally conform to the requirements of ACI 305.

**4.8.2.2 CONCRETE REINFORCEMENT INSTALLATION.** Concrete reinforcement shall be installed in accordance with ACI (American Concrete Institute) standard requirements for reinforced concrete and generally as follows.

**A. BENDING.** Reinforcing bars shall be accurately formed to the dimensions indicated on the plans. Bends for stirrups and ties shall be made around a pin having a diameter not less than two (2) times the minimum thickness of the bar. Bends for other bars shall be made around a pin having a diameter not less than six (6) times the minimum thickness of the bar, except that for bars larger than one (1) inch, the pin shall be not less than eight (8) times the minimum thickness of the bar.

**B. SPLICING.** Splicing of bars at points other than where shown on the plans will be permitted only by approval of the city's representative.

Splices of reinforcement at points of maximum stress shall be avoided wherever possible, and when used shall be staggered and in accordance with ACI Standards. The minimum overlap for a lapped splice shall be twenty-four (24) bar diameters, but not less than twelve (12) inches and properly tied together.

C. **PLACING.** All reinforcing bars shall be placed accurately in the position shown on the plans and shall be securely held in position by annealed iron wire ties of not less than sixteen (16) gauge or suitable clips at intersections. All reinforcing bars shall be supported by metal supports, spacers, or hangers, in such a manner that there will not be any displacement while placing concrete.

D. **EMBEDMENT AND PROTECTION.** All reinforcing steel shall be protected by concrete embedment and protective cover as shown in Table 4.17, such cover in each case being the shortest distance between the face of the form or concrete surface, and the nearest edge or face of the reinforcement.

**TABLE 4.30  
REINFORCING BAR CLEARANCE**

<b>LOCATION OF REINFORCEMENT</b>	<b>COVER</b>
Bottom bars - where concrete is deposited against ground without use of forms.	Not less than 3"
Main bars - where concrete is exposed to the weather or exposed to the ground but placed in forms.	Not less than 2"
Bars in slabs and walls not exposed to the ground or weather.	Not less than 1"

**4.8.2.3 CURB, GUTTER, AND SIDEWALK CONCRETE PLACEMENT.** The concrete shall be placed either by an approved slipform/extrusion machine, by the formed method, or by a combination of both methods. Curb and gutter shall be placed as follows:

A. **MACHINE PLACEMENT.** The slipform/extrusion machine shall place, spread, consolidate, screed, and finish the concrete in one complete pass to provide a dense and homogeneous concrete section. A minimum amount of hand finishing should be necessary. The machine shall shape, vibrate, and/or extrude the concrete for the full width and depth of the concrete section being placed. It shall be operated with as nearly a continuous forward movement as possible. All operations of mixing, delivery, and spreading concrete shall provide for uniform progress, with stopping and starting of the machine held to a minimum.

**B. FORMED METHOD.** The forms shall be of wood, metal, or other suitable material straight and free from warp, having sufficient strength to resist the pressure of the concrete without displacement and sufficient tightness to prevent the leakage of mortar. Flexible or rigid forms of proper curvature shall be used for curves having a radius of one hundred feet, or less.

Forms shall be cleaned and coated with an approved form-release agent before concrete is placed against them.

The concrete shall be deposited into the forms without segregation and then tamped and spaded or mechanically vibrated for thorough consolidation. Front and back forms shall be removed without damage to the concrete after it has set.

**C. FINISHING.** The concrete shall be finished smooth, by a wood or magnesium float and then given a final surface texture using a light broom or burlap drag unless otherwise specified or directed. Concrete that is adjacent to forms and formed joints shall be edged with a standard jointer or edging tool as shown in the standard drawings. The top, face, and flow-line of the curb, and the top of driveway apron, shall be finished true to line and grade without any noticeable surface irregularities.

The Contractor shall be responsible for neatly stamping an "S" in the curb face at all sewer lateral locations and a "W" in the curb face at all water lateral locations along the curb.

The gutter shall not pond water. The surface of the curb and gutter shall not exceed more than one fourth (1/4) of an inch in ten (10) feet. No part of the exposed surface shall present a wavy appearance.

**D. JOINTING.**

D.1 Contraction Joints. Transverse weakened-plane contraction joints shall be constructed at right angles to the curb line at intervals not exceeding the values in accordance with standard drawings. Where the sidewalk abuts the curb and gutter, joints should align unless otherwise approved by the city's representative. Joint depth shall at least be one quarter (1/4) of the cross-section depth of the concrete. Generally, surface areas shall not exceed fifty square feet without contraction joints unless otherwise approved by the City's representative.

Contraction joints may be sawed, hand-formed, or made by placing division plates in the formwork. Sawing shall be done within twenty-four hours after the concrete has set to prevent the formation of uncontrolled cracking. The joints may be hand-formed either by using an appropriate jointing tool, or a thin metal blade to impress a plane of weakness into the plastic concrete, or by inserting one eighth (1/8) inch thick steel strips into the plastic concrete temporarily. Steel strips shall be

withdrawn before final finishing of the concrete. Where division plates are used to make contraction joints, the plates shall be removed after the concrete has set while the forms are still in place.

D.2 Expansion Joints. Expansion joints for curb and gutter shall be constructed at right angles to the curb line at no greater than one hundred fifty (150) foot intervals, at immovable structures and at points of curvature for short-radius curves. Spacing for sidewalk expansion joint shall not exceed twenty (20) feet. Filler material for expansion joints shall conform to requirements of ASTM D-994, D-1751, or D-1752 and shall be furnished in a single one-half inch thick piece for the full depth and width of the joint.

Expansion joints in a slip formed curb and gutter shall be constructed with an appropriate hand tool by raking or sawing through partially set concrete for the full depth and width of the section. The cut shall be only wide enough to permit a snug fit for the joint filler. After the filler is placed, open areas adjacent to the filler shall be filled with concrete and then troweled and edged. Contaminated concrete shall be discarded.

Alternately, an expansion joint may be installed by removing a short section of freshly extruded curb and gutter, immediately installing temporary holding forms, placing the expansion joint filler, and replacing and reconsolidating the concrete that was removed. Contaminated concrete shall be discarded.

D.3 Other Jointing. Construction joints may be either butt or expansion-type joints. Curbs and gutters constructed adjacent to existing concrete shall have the same type of joints as in the existing concrete with similar spacing, however, contraction joint spacing shall not exceed ten feet.

A silicone joint sealer as defined in ASTM C 962 shall be applied to all form-plate expansion joints. The silicone joint sealer shall be applied under pressure to a depth of not less than two inches from the outside surface of the curb and gutter.

**E. PROTECTION.** At all times during the construction of the project, the Contractor shall have materials available at the site to protect the surface of the plastic concrete against rain or other detrimental elements. These materials shall consist of waterproof paper, plastic sheeting, or other approved material. For slip-form construction, materials to protect the edges shall also be required.

When concrete is being placed in cold weather and the temperature is expected to drop below 35 degrees F., suitable protection shall be provided to keep the concrete from freezing until it is at least seven (7) days old. Concrete damaged by frost action shall be removed and replaced.

F. **CURING.** Concrete shall be cured for at least three days after placement to protect against loss of moisture, rapid temperature change, and mechanical damage. Liquid membrane curing compound, or other approved methods, or a combination thereof may be used as the curing material. Membrane curing shall not be permitted in frost-affected areas when the concrete will be exposed to de-icing chemicals within thirty days after completion of the curing period.

G. **BACKFILLING.** At least three days after placement and after form removal, the concrete shall be backfilled to the lines and elevations as shown on the drawings or as required by the city's representative. The length of time may be shortened if it can be demonstrated that the concrete has reached design strength. Any concrete damaged during backfill or other operations, shall be removed and replaced as directed by the city's representative.

H. **CONCRETE REPAIR.** In lieu of removing and replacing concrete containing minor cracks, the City's Representative may direct the Contractor to repair the affected sections by sawing, routing, cleaning, and sealing the cracks. All cracks repaired shall be sealed with a polyurethane TTS-230 type II crack filler or an approved silicone base joint sealer. Where modifications are to be made to existing concrete, the edges to be poured against shall be sawcut in neat, straight lines and the new concrete shall be edged with a standard edging tool.

I. **WEATHER LIMITATIONS.** Concrete shall not be poured when there is likelihood of freezing. During the curing period, the concrete shall be protected by means of insulating covers to prevent freezing of the concrete for a period of not less than seven days after placing. Equipment for protecting the concrete from freezing shall be available at the job site prior to placing concrete. Care shall be exercised to protect edges and exposed corners from freezing.

Hot weather concreting shall be in accordance with the latest ACI 305 Standards for Hot Weather Concreting.

**4.8.2.4 CONCRETE BASE MATERIALS PLACEMENT.** The placement of concrete base materials under curb, gutter and sidewalk shall conform to Section 4.5.7 of these standards.

**4.8.3. QUALITY CONTROL.** All concrete and base materials shall be placed in accordance with these standards and tested as follows. These are minimum requirements and additional testing may be required by the city's representative or the Project Geotechnical Engineer.

Testing documentation provided to the city's representative shall fully address the requirements of these standards.



**4.8.3.1 CONCRETE TESTING.** Minimum testing of the concrete shall be as follows:

Mix Design

Certification: Upon request of city representative.. Testing shall be according to the latest ASTM standards.

Compressive

Strength Tests: One set of four cylinders for each fifty cubic yards of concrete placed or portion thereof. Tests shall be according to ASTM C-31.

Air Entrainment: Tested at beginning of placement until two consecutive loads pass. Other tests shall be taken as required. Tests shall be according to ASTM C-231.

Slump Tests: Tested at beginning of placement until two consecutive loads pass. Other tests shall be taken as required. Tests shall be according to ASTM C-143.

**4.8.3.2 CONCRETE BASE MATERIAL TESTING.** Minimum testing of the curb, gutter and sidewalk base materials shall be as follows:

Gradation Tests: One test per five hundred (500) lineal feet of curb & gutter or fraction thereof. One test per five hundred (500) lineal feet of sidewalk and driveway, or fraction thereof. The sieve analysis shall be according to ASTM C-136, C-117.

Proctor: One determination for each source of base course as necessary to provide required compaction testing. Test shall be according to ASTM D-1557, Method A or D (modified proctor).

Moisture

Density Tests: One test per three hundred (300) lineal feet of curb & gutter and one test per three hundred (300) lineal feet of a combination of sidewalk and driveway or fraction thereof. Moisture content shall be at plus or minus two percent of optimum. Proper moisture shall be maintained until the concrete is poured. Tests shall be according to ASTM D-1556 or D-2922 and D-3017.

Thickness: At each location of the moisture density test, a thickness of the base material should be verified. The thickness shall meet the minimum city or project design requirement. If sufficient observation has been made by the city's representative to verify required thickness, the city's representative may waive thickness testing. Said waiver must be in writing and the testing agency should be notified.

No single measured thickness shall be less than the required ~~thick~~

**4.8.3.3 ACCEPTANCE.** A total of four (4) concrete test cylinders shall be taken at time of pouring from loads passing the requirements of section 4.8.3.1. One cylinder shall be broken at seven (7) days and shall be used as an indication of future strength. Two (2) cylinders shall be broken at twenty-eight (28) days. If the average of the twenty-eight-day breaks is below minimum compressive strength, the concrete may be rejected unless retests prove otherwise. At the Contractor's option, the fourth cylinder (the hold cylinder) may be broken at twenty-eight (28) days, and included with the average, or it can be held for future testing if additional tests are needed.

Concrete with an average compressive strength below the required strength shall be reviewed by the City's Representative. The "hold" cylinder, if available, may be broken or other specialized tests (such as a spectrum analysis) may be required. If additional tests are required to determine if strength tests are representative, they shall be performed by coring in accordance with ASTM C-42 method or other acceptable non-destructive methods. The re-tested strength shall be the average of three cores (or other acceptable method). The city's representative may accept the concrete because of these additional tests or may require the work to be removed and replaced. The city's representative shall make the final decision. All costs incurred in resampling and retesting are not the responsibility of the City.

All concrete not in compliance with these standards shall be removed and replaced. Any costs for testing the re-work are not the responsibility of the city.

## **4.9 RESTORATION OF EXISTING SURFACE IMPROVEMENTS.**

**4.9.1 INTRODUCTION.** The Contractor shall be responsible for the protection and restoration, or replacement, of all existing improvements on public or private property and all improvements placed during the progress of the work. Existing improvements shall include, but not be limited to, asphalt, curbs, gutters, ditches, driveways, culverts, fences, signs, sidewalks, utilities, landscaping, and walls, etc. All existing improvements damaged during construction shall be reconstructed to equal or better condition than that which existed. However, as a minimum, the requirements contained in these specifications shall be adhered to.

All traveled surfaces shall be always maintained flush with the existing surfaces until permanent repairs are completed.

Prior to the beginning of any work activity involving tunneling under, or making any excavation in any street, alley or other public place, the Contractor shall comply with all requirements for permits and bonding. The Contractor shall also comply, during the work activity, with all the requirements contained within Section 2.5, BARRICADES AND WARNING SIGNS - WORK AREA PROTECTION, of these specifications.

**4.9.2 GRAVEL SURFACES.** Where existing gravel surfaces are damaged due to

trenching or other works the surfaced areas (such as roads and driveways) shall be restored and maintained as follows.

The gravel shall be placed deep enough to provide a minimum of six inches thickness, or to match the thickness of existing material, or to these specifications, whichever is greater.

The gravel shall be placed and compacted in the trench (or other work) at the time it is backfilled. The surface shall be maintained by blading, sprinkling, rolling, or adding gravel to maintain a safe uniform surface satisfactory to the city's representative. Excess material shall be removed from the premises immediately.

Material for use on gravel surfaces shall conform to the requirements contained within these specifications.

**4.9.3 BITUMINOUS SURFACES.** Where existing bituminous surface is damaged due to trenches or other works, the bituminous surfaced roads, driveways, parking areas, etc., shall be restored within five (5) days as follows:

Mud or other soft or spongy material shall be removed from the trench and the space filled with granular backfill to within twelve (12) inches of finished grade. The granular backfill shall be rolled and compacted to a minimum of ninety-five (95) percent of maximum dry density in layers not exceeding six (6) inches in compacted thickness. Base gravel shall then be placed to a depth equal to the original gravel base or the requirements of these specifications, but not less than six (6) inches thick and compacted to a minimum of ninety-five (95) percent of maximum dry density.

Prior to permanent resurfacing, the Contractor shall saw-cut the existing paving to provide vertical, clean, straight lines as nearly parallel to the centerline of the trench as practical. The existing bituminous paving shall be cut back beyond the limits of any excavation so that the edges of the new paving will rest on at least six (6) inches of undisturbed base material.

Pavement restoration shall include tacking of pavement edges with type SS-1H bituminous material and placing and compacting plant mix asphalt in accordance with these specifications to the level of the adjacent pavement surfaces.

The bituminous surface shall be restored by standard paving practices to a thickness equal to the original pavement or the requirements of these specifications, but in no case less than three inches. The finished repaired surface shall not deviate more than one quarter (1/4) inch (vertically) from the existing road surface. Any deviations greater than that specified shall be immediately removed and replaced to the proper standards.

**4.9.4 CONCRETE SURFACES.** All concrete curbs, gutter, sidewalks, and driveways

shall be removed and replaced to the next joint or score line beyond the damaged or broken sections; or saw-cut to neat, plane faces. All new concrete shall match, as nearly as possible, the appearance and texture of adjacent concrete improvements unless adjacent improvements do not meet these specifications.

All damaged base material shall be restored and compacted in accordance with these specifications.

## SECTION 5

### SIGNING AND PAVEMENT MARKINGS

**5.1 INTRODUCTION.** This section covers street signing and pavement markings.

**5.2 SIGNING MATERIALS, FABRICATION AND PLACEMENT.** All traffic, street name and other roadside signage shall follow the requirements for materials, fabrication and installation outlined in the standard drawings and these specifications.

**5.2.1 STREET NAME SIGNS.** The sign face materials shall consist of reflective high intensity grade sheeting (or better). Engineer or similar grade materials shall not be used. The sign face colors shall be green for public streets and blue for private streets. The street sign blanks shall consist of high tensile, degreased aluminum in accordance with the standard drawings. The street name sign face layout detail, as shown on standard drawings, shall be followed. The "Street Name Sign Designation Form" found in the standard drawings shall be completed and approved by the City Address Coordinator prior to the fabrication and installation of any new street name signs.

The street name signs shall be installed on galvanized steel posts that conform to the requirements contained in the standard drawings. The installation method and location shall be in accordance with the standard drawings and the MUTCD.

**5.2.2. TRAFFIC SIGNS.** All traffic signs shall conform to the requirements relating to color, face, size, markings, lettering, and location of installation found in the Manual of Uniform Traffic Control Devices for Streets and Highways (MUTCD). Traffic sign face material shall consist of retro-reflective high intensity grade sheeting (ASTM D 4956).

Traffic sign blanks shall consist of 0.1-inch-thick high tensile degreased aluminum alloy in, accordance with 6061-T6, with alodine 1200 finish.

All traffic signs shall be installed on galvanized steel posts in accordance with the standard drawings.

**5.2.3 VISIBILITY.** All street name and traffic signs shall be installed in such a manner as to provide adequate advance visibility for an approaching driver in accordance with MUTCD and other approved standards.

**5.3 PAVEMENT MARKINGS.** Pavement markings shall include all traffic lane striping, pavement words and symbols, and other traffic-oriented street markings.

The standards regarding color, type, size and layout of pavement markings *Manual on Uniform Traffic Control Devices for Streets and Highways*. However, in such cases where the Utah Department of Transportation standards take precedence, they should be followed.

### 5.3.1 LINE TYPES

A. Longitudinal Markings. Pavement markings that are generally placed parallel and adjacent to the flow of traffic such as lane lines, center lines, edge lines, channelizing lines, and others.

B. Transverse Markings. Pavement markings that are generally placed perpendicular and across the flow of traffic such as shoulder markings; word, symbol, and arrow markings; stop lines; crosswalk lines; speed measurement markings; parking space markings; and others.

C. Solid Lines. Solid lines shall consist of a four (4) inch wide solid white or yellow lines, unless otherwise directed (see turn lane lines and stop bars below).

D. SKIP (BROKEN) LINES. Skip lines shall consist of line segments and gaps on a 3 to 1 ratio. The line segment shall be four (4) inches wide (white or yellow line) and generally ten (10) feet long. The gap segment shall generally be thirty (30) feet long.

E. DOUBLE LINES. A double line is typically longitudinal and consists of two four (4) inch wide solid yellow lines separated by a minimum four (4) inch wide space.

F. TWO-WAY LEFT TURN LANES. Two-way left turn lanes are longitudinal and consist of two four (4) inch solid yellow lines on each side of the lane, with an adjacent four (4) inch yellow skip line on the inside of the two solid lines. The solid and adjacent skip lines are separated by a four (4) inch wide space. The lane is typically 14-feet wide but can be reduced (12-foot minimum) at the discretion of the city representative.

G. LANE LINES. Lane lines shall consist of a four (4) inch wide skip line, white in color. Lane lines separate lanes of traffic travelling in the same direction. A four (4) inch wide or wider solid white line may be used as the lane line in critical areas where it is advisable to discourage lane changing, such as on bridges having width restrictions and in intersection areas where lane changing disrupts traffic flow.

H. TURN LANE LINES. Turn lane lines are longitudinal lines associated with left-turn or right-turn only lanes and are eight (8) inches wide and solid white.

I. STOP BARS. Stop bars are solid white transverse markings. Width shall be twelve (12) inches at typical stop-controlled intersections. Stop bars shall be twenty-four (24) inches when placed in conjunction with a school crosswalk or at a signalized intersection where no crosswalk is present.

### 5.3.2 PAVEMENT WORD AND SYMBOL MARKINGS. Shall be in accordance with

the MUTCD.

**5.3.3 TRAFFIC PAINT.** Unless otherwise approved by the city representative, traffic paint shall conform to the latest requirements contained in the State of Utah Department of Transportation "Standard Specifications for Road and Bridge Construction". Traffic paint shall be applied only when all the following conditions are met:

- A. The air temperature is above forty (40) degrees Fahrenheit.
- B. The temperature of the surface to be painted is between forty (40) and one hundred (100) degrees Fahrenheit.
- C. The surface to be painted is clean and dry, and
- D. The weather is not windy, foggy, or humid.

Painting shall be done in a neat and workmanlike manner. Paint shall be applied smoothly and uniformly in accordance with the manufacturer's specifications. The finish shall be uniform in appearance and coverage.

**5.3.4 TEMPORARY MARKINGS.** Temporary markings may be required until permanent markings can be properly placed. Temporary pavement markings shall be reflectorized traffic paint or other material approved by the city's representative.

## SECTION 6

### STREET LIGHTING

**6.1 INTRODUCTION.** All streetlights erected within the city, whether in a public street, easement, subdivision, or in any building project requiring street improvements, shall conform to the standards covered in this section of these specifications. All work and materials shall be in conformance with the latest edition of the City of St. George Underground Power Construction Standards and Specifications.

**6.2 STREETLIGHT POLE.** All street lighting and other lighting shall conform to the latest edition of the St. George City Policy number 5.6 entitled, A Street Lights and Yard Lights.@ This policy is available from the City Water and Power Department. A copy of the policy dated January 13, 1987, with latest revision date of September 3, 1998, is included in Section 6.3 for reference only. Prior to using this policy, it is required that the user contact the Water and Power Department to be certain that the most current edition is being used.

**6.3 POLICY NUMBER 5.6 Street Lights and Yard Lights@.** See following pages.

**SUBJECT:** Street Lights and Yard Lights

**POLICY NO.:** 5.6 **APPROVED BY:** City Council

**EFFECTIVE DATE:** 01/13/87 **METHOD OF APPROVAL:** Water & Power

Revised 01/25/94 Staff and Board recommended to City Council

Revised 12/24/96

Revised 09/03/98

**POLICY:** It is the policy of the City that all streetlights erected in the City shall adhere to the following:

**PURPOSE AND OBJECTIVE:** To ensure streetlights are installed according to uniform construction guidelines and equipment specifications.

**PROCEDURES AND RESPONSIBILITIES:**

1. Term. This policy or specification will be reviewed and reevaluated for costs on a three-year basis.
2. Standard Lights and Equipment. The lights shall be mounted on an aluminum or galvanized steel, single member arm pole designed to withstand 100 mile per hour wind (certified). All poles shall have an access hole at or near the base for access to the wiring. The overhang shall not exceed 25% of the mounting height. The following is the guideline to be used for plat preparation:



Road Right Mounting Lamp Pole  
Of Way Width Height Wattage Spacing  
Only Historical 25-50' 16' 150 220' - 250'  
25-50' 35' 250 300' - 350'  
51-62' 40' 250 250' - 300'  
63-72' 40' 400 250' - 300'

This may be subject to change as determined by the Power Department Inspector as per any safety requirements or instructions. All arms shall be 2 3/4" O.D. (2" pipe) laminar mounting. All poles shall be anchoring base poles and the foundation design shall be adequate for the length of pole, the arm that's being installed, the soil conditions and the 100 mile per hour winds. (As determined by the Utility Engineer.) All luminaries shall be 120-volt High Pressure Sodium Lamps with photo control. They will be:

A. Photocell  
Fisher Price Model # 7790B-SSS-105-285-VAC  
Fixture  
Cooper Lighting Model OVD # 24-S-W-W-3-F-H4  
Lamp  
Sylvania Item # 67572-LU250/Plus/ECO 250 Watt  
67312-LU400/Plus/ECO 400 Watt

If a residential subdivision or project has a 50' wide or less roadway right-of-way and would like a more aesthetic historical light, they may order the following:

B. HADCO  
- Historical 14-foot spun alum pole with base  
(Verde green) # (P-2060-G-14')  
- Light Fixture # (S5451-F-G-PC)  
- Lights # (HPS 150 Med E17D) Mogul Base

This specification will be evaluated on an Aase equal@ basis. The corresponding foundation base is found in the Water & Power Department Underground Construction manual. The spacing of these lights will be designed by the Water & Power Department staff.

3. If a residential subdivision or project has 50' wide or less roadway and would like a more aesthetic decorative square light, they may order the following:

Cooper Utility Lighting  
Pole: SSS6X35S-F-M-G - Bronze  
SSS6X35S-Y-M-G - Black  
Fixture: RCL25-S-H-W-2D-4 250-  
WattRCL40-S-H-W-2D-4 400 Watt  
Lamp and Photocell: Same as standard Cobra Head Light

There will be no substitutes to the above specifications without Power Department Engineer's approval.

3. Non-Standard Street Lights. Where a developer has been allowed to install nonstandard streetlights in a subdivision prior to the adoption of this policy, he may continue to do so in that subdivision provided a high-pressure sodium lamp is used. A homeowners' association or other responsible party may install non-standard streetlights in a neighborhood provided they use high pressure sodium lamps. Even though a high-pressure sodium lamp is used, the city will not maintain these streetlights due to non-conformity. Substandard streetlights currently not maintained by the city are as follows:

- All DERE A area lights
- All private PUD's including Man O War Bridge
- Spring tree Apartments
- The Ridge (PUD)
- Sports Village Road in Green Valley
- Sunbrook SID, Road and corresponding subdivision (light only)
- Green Valley Phase 4
- Any other private PUD lights

Further, any non-standard street light system must be approved by the Community Development Director to ensure that public safety and planning concerns are considered. Power shall be provided to non-standard streetlights by the City at no cost to the association or developer. The above will be updated periodically by the Power Department.

4. Installation. Standard streetlights shall be installed at the owner/developer's expense in all new subdivisions or projects. Standard lights may be installed in existing neighborhoods upon the execution by responsible parties of the Street Light Installment Agreement which is a part of this policy. The design and cost of the streetlight will be determined by the city and incorporated into the said Agreement. Customers requesting street light installation will be required to meet with the Water and Power staff during a regularly scheduled planning meeting to discuss details and procedures. Maintenance and lamps as well as power will be supplied by the City at no cost to standard streetlights installed in accordance herewith. An executed Street Light Installment Agreement will be recorded with the County Recorder whenever appropriate. All new streetlights installed in the Dixie Escalante REA service area will not be maintained by the City of St. George Power Department but will be maintained by the DERE A and a \$12/month fee per light will be billed to Public Works. If the Mayor, City Council, or City Manager feel a streetlight should be installed at City expense for safety or other reasonable public consideration, the Power Department will install the streetlight(s) as directed and according to this policy. The cost of the streetlight(s) will be billed to the General Fund of the City at cost.

5. Yard Lights. The city will install lights on existing poles for the illumination of yards or other private areas at a cost of \$75.00 for installation and \$12.00 per month plus tax for maintenance. Yard lights must be kept in service for no less than two years. If it is necessary for a pole/power service to be installed, the actual cost thereof will be paid by the person requesting the light in lieu of the \$75 installation charge. It will be the City's responsibility to repair or replace any yard lights under this agreement. It will be the customer's responsibility to inform the Utility Office

of any non-operational yard lights. Monthly maintenance charges shall be subject to adjustment by mutual written agreement between the City and the customer. Yard lights shall not be metered, but landscaping components or other lights that are considered substandard for purposes of this section shall not be considered to be yard lights and shall be within the service measured by the property owner's private meter.

## **STREET LIGHT INSTALLATION AGREEMENT**

**NOTE:** Contact City Water and Power Department for current agreement AGREEMENT made as of the day of , 19 , between the City of St. George, herein referred to as the "City", and , St. George, Utah, herein referred to as the "Property Owner", wherein it is agreed that the best interests of the City and the Property Owner will be served by the installation of one or more street lights in the Property Owner's neighborhood. In consideration of the installation by the City of that street lighting described on Exhibit "A", attached hereto, and made a part hereof, the undersigned property owner does agree to pay the sum of \$ as his prorata portion of the cost thereof, such amount payable in three equal annual installments of \$ each, without interest, until paid in full. The Property Owner agrees that in the event of a default in the payment of any installment when due, the City shall be entitled to charge and the Property Owner shall pay interest on the entire balance owing at the rate of 18% per annum, and the City shall have the right to accelerate the entire remaining balance and declare the same immediately due and payable in the event of such default. In the event suit is commenced to collect any delinquent amount hereunder, the Property Owner does agree to pay reasonable attorney's fees in connection therewith. The first installment shall be due on the first day of the month following completion of the installation, and on the first day of that same month each year thereafter. The payment of installments shall be made at the City Office Building on or before the date they are due, and annual notice from the City of the due date of such installments is hereby waived.

The Property Owner agrees to provide rights-of-way, if any are needed over or across property owned by the undersigned for the purpose of such installation. He does further agree that in the event of a sale of the property within the area described on Exhibit "A" and affected hereby, the successors in interest thereon shall be obligated to make the payments provided hereunder, and this agreement recorded as notice to subsequent purchasers of such obligation.

The engineering required for installation of the streetlights shall be provided by the City without cost, and such engineering is therefore not included in the amount for which the Property Owner agrees to pay. Electricity to illuminate the streetlights and long-term maintenance and repair of the lighting system shall be the responsibility of the City.

The undersigned Property Owner has read and understands the terms of this agreement and upon installation of the lighting provided for herein, he/she and all successors shall be obligated hereunder, and any other verbal agreement of any type between the parties is merged into this agreement.

Upon payment in full of all amounts owing hereunder, this agreement shall become null and void, and the City shall record a release hereof upon request.

DATED on the day and year first above written.

\_\_\_\_\_  
Property Owner

\_\_\_\_\_  
Street

\_\_\_\_\_  
City  
STATE OF UTAH)

ss.  
County of Washington)  
SUBSCRIBED AND SWORN to before me this day of, 20\_\_\_\_\_.

\_\_\_\_\_  
Notary Public  
My commission expires:

## SECTION 7

### POWER SYSTEM

**7.1 INTRODUCTION.** This section covers the specifications for off-site improvements for power system construction and defines the materials and practices required. Policies and procedures relating to electrical construction and maintenance practices are outlined in the Underground Power Construction Standards and Specifications.

Where conflict exists between these and said standards, said standards shall govern. All materials and equipment shall be furnished by the Contractor and shall be installed in a workmanship like manner in compliance with the current edition of the National Electrical Code and the National Electric Safety Code. Where code conflicts occur, these specifications and local regulations will govern.

#### 7.2 ELECTRIC SERVICES.

**7.2.1 POWER CONNECTION.** Only authorized employees of the Power Department will be permitted to connect, or disconnect, electrical service to, or from, their power lines.

**7.2.2 ELECTRIC SERVICE AGREEMENT.** Each applicant for electric service within the municipal power service area must sign a standard electric service agreement. The applicant must supply the required information relating to the amount of load, voltage required, phase required and the purpose for which the service will be used. In the absence of a signed agreement, the acceptance of electric service will be deemed as constituting acceptance of the Power Department requirements and regulations. Large industrial, and/or commercial customers shall contract with the Power Department to meet their special requirements.

**7.2.3 CUSTOMER SERVICE FACILITIES.** The Customer shall provide and install an approved meter socket having the proper terminal arrangement and capacity to adequately accommodate their service requirements. The Customer shall also extend the building wiring from the meter socket to the service attachment. The Customer shall provide an adequate and substantial means by which Power Department personnel can attach appropriate service line equipment to the building. All service attachments shall have a minimum clearance of ten feet above the ground level, or above other areas where people could come in contact with the power lines. Ample space shall be provided around the meter attachment to permit an unobstructed area for meter installation and maintenance. A minimum space of three inches shall be left between each meter socket and between meter sockets and other equipment. All equipment on the load side of the building service attachment, (except the meter and metering equipment, which will be furnished by the Power Department) shall be the responsibility of the Building Owner. All building wiring shall conform to applicable wiring codes. The Customer shall be responsible for providing adequate and proper equipment to protect their equipment against overload, over or under voltage, or phase failure. The Power Department takes reasonable precaution to prevent any abnormal condition but does not guarantee that such conditions will not occur. Any

proposed change in existing meter, or service locations, or conditions, must be approved by the Power Department or service may be discontinued.

**7.3 MATERIALS AND WORKMANSHIP.** All materials and workmanship shall be first quality in every respect, plumb and true, and comply with the specific requirements of the approved layout drawings. The previously referenced Power Department standards will be adhered to. No work shall be embedded in concrete, backfilled, or otherwise covered or concealed, until it has been inspected and approved by Power Department personnel. If any portion of the completed system fails to operate satisfactorily due to defects in material or workmanship, within one year of acceptance, it shall be corrected at the Customer's expense to the satisfaction of the City's Representative.

**7.4 CONTROL OF GROUND WATER.** All trenches shall be kept free from water during excavation, fine grading, cable laying, and embedment operations. Where the trench bottom is mucky or otherwise unstable because of the presence of ground water, and in cases where the static ground water elevation is above the bottom of any trench excavation, such ground water shall be lowered to the extent necessary to keep the trench free from water and the trench bottom stable when the work within the trench is in progress.

Surface water shall be prevented from entering the trenches.

**7.5 EXCAVATION AND BACKFILL.** Excavation of trenches shall be as shown on approved layout drawings. The City's Representative(s) shall have the right to direct field changes where, in his judgment, alignment or topography problems are evident. Trenches shall be straight and the bottom free from water. All blocking or shoring materials shall be removed during backfill procedures. Where trenching is required in dedicated streets, or other public rights-of-ways, all trenches shall be backfilled in compliance with these specifications. The developer shall assume full responsibility for street failure where trenching operations have been performed. Where soil conditions require bedding material, sand shall be placed above and below direct buried cables, or conduits, in two backfill operations. The trench shall then be compacted to ninety (90) percent of relative maximum dry density, unless the trenches are in streets or other public rights-of-ways, where they shall be compacted to a minimum of ninety-five (95) percent of relative maximum dry density for granular soils and ninety (90) percent for fine grain soils as detailed in these specifications. Bedding material specifications shall be as follows:

**SAND:** Sand shall be well graded, have rounded to sub-rounded particles with one hundred (100) percent of the material passing a three-eighth (3/8) inch sieve, and no more than twenty (20) percent passing a number two hundred (200) sieve. No open graded material, such as "pea gravel" will be permitted for cable bedding. The material shall be non-plastic as per ASTM D-432 and D-424, and the cable shall be embedded with a minimum depth of four (4) inches of sand below the cable and a minimum depth of eight (8) inches of sand over the cable.

**7.6 CONCRETE.** All concrete poured in the field shall be ready-mixed and shall meet the requirements of these specifications, unless otherwise permitted by the City's Representative

**7.7 METERS.** To permit access to the metering installation and to provide working safety for personnel, a clear working and standing space shall be provided in front of all meters. This area shall be located entirely on the Customer's property. The working space shall be kept clear and unobstructed and shall extend a minimum of three feet from the face of the meter socket or instrument transformer compartment. The working space shall be sufficiently wide to permit ready access to the complete metering installation and in no case

shall it be less than three feet wide and have a height clearance of no less than six feet. For each meter, the Customer shall furnish and install a switch or other approved disconnecting device. The disconnecting device shall be installed on the load side of the meter and shall control all of, and only the energy registered by that meter. All meters and enclosures for meters, metering equipment and service entrance equipment on the line side of the meter, shall be sealed only by the Power Department personnel. Seals shall not be broken except by an authorized representative from the Power Department. No person shall be permitted to tamper with, or in any way interfere with a meter or its connections, as placed by the Power Department.

For reasons of public safety, maintenance of service, and reliability of metering; meters shall not be installed in the following areas:

1. In any location that is not readily accessible.
2. In any location which is hazardous to personnel.
3. On any surface subject to excessive vibration.
4. In any elevated or depressed area that does not have access provided by means of a ramp or clear stairway of normal tread and which conforms to building code requirements.
5. In any substation area or transformer vault.
6. In common areas with dogs.

---

---

# Santa Clara City Construction Design Drawings -Updated



*Special Thanks To:*

*St. George City*

*Washington City*

*Todd Edwards of Bush & Gudgell*

*Rick Rosenberg of Rosenberg & Associates*

*Jerry Amundsen of Carter & Burgess*

*Marvin Wilson of Sunrise Engineering*

Updated: Feb 8, 2023

---



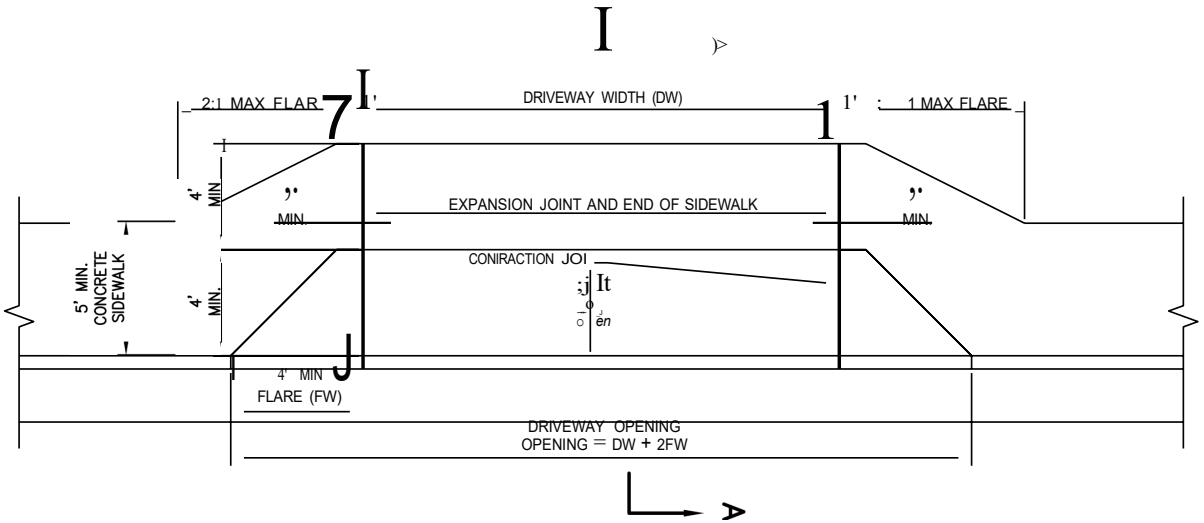

FLARED DRIVEWAY WITH ADJACENT SIDEWALK - PLAN VIEW

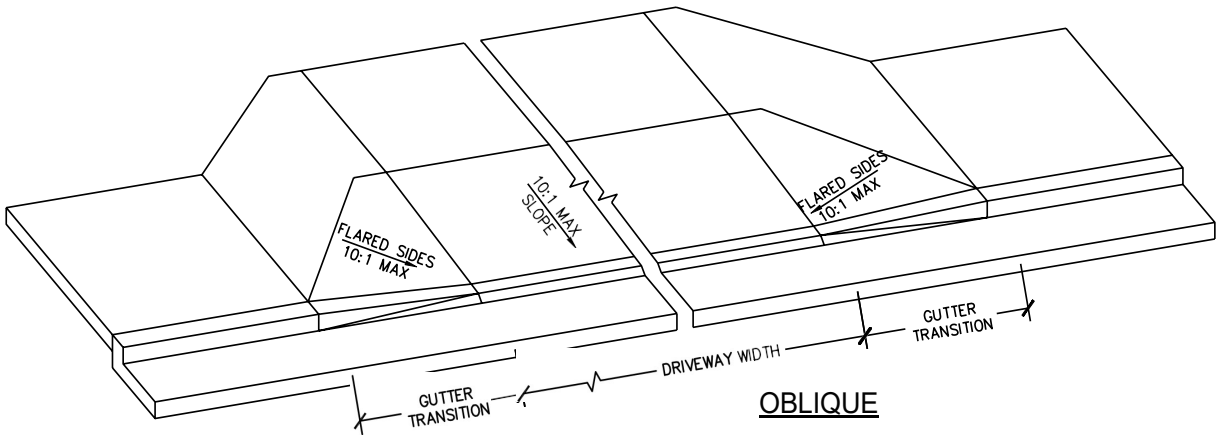

OBLIQUE

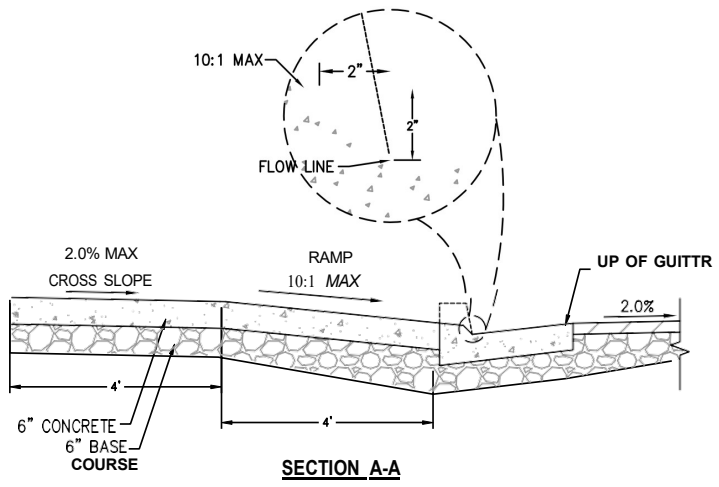

SECTION A-A

- NOTES:
1. WIDTH OF DRIVEWAYS VARIES WITH USE - SEE CITY STANDARDS OR CONTACT CITY PUBLIC SERVICES DEPARTMENT.
  2. DRIVEWAYS WITH COMMERCIAL OR INDUSTRIAL USE REQUIRE ADDITIONAL THICKNESS SEE PUBLIC SERVICES DEPARTMENT

REVISIONS			SANTA CLARA CITY PUBLIC SERVICES DEPARTMENT		STANDARD DWG. NO.	
DATE	DESCRIPTION	BY	DRIVEWAY APRON DETAILS		111	1 OF 1
					APPROVED: FEB B 2023	
			DATE: DEC 2022	BY: LB		

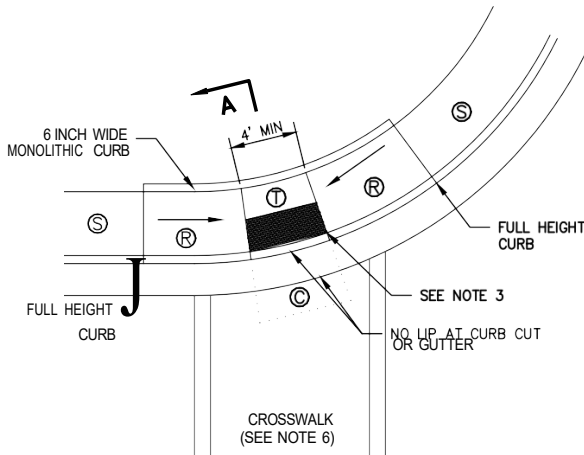

**CORNER PEDESTRIAN RAMP  
SINGLE CROSSING**

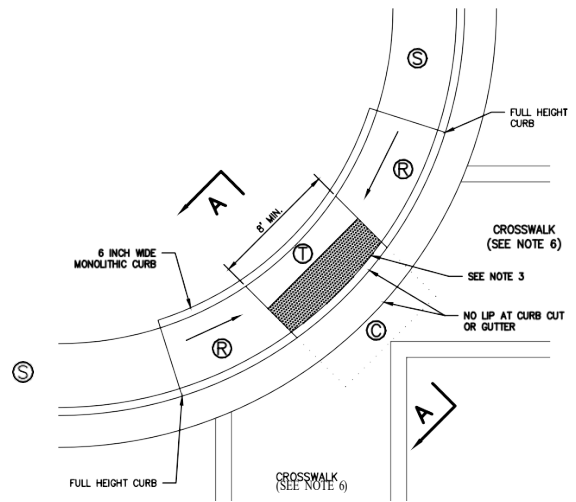
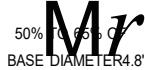

**CORNER PEDESTRIAN RAMP  
DUAL CROSSING**

TRUNCATED

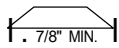

1-1 3/8" MAX-1

TRUNCATED DOME

1 5/8" MIN  
2 3/8" MAX

IN SQUARE GRID

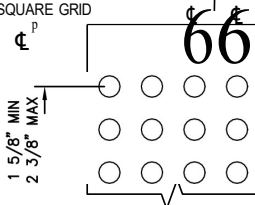

**DETECTABLE WARNING SURFACE**

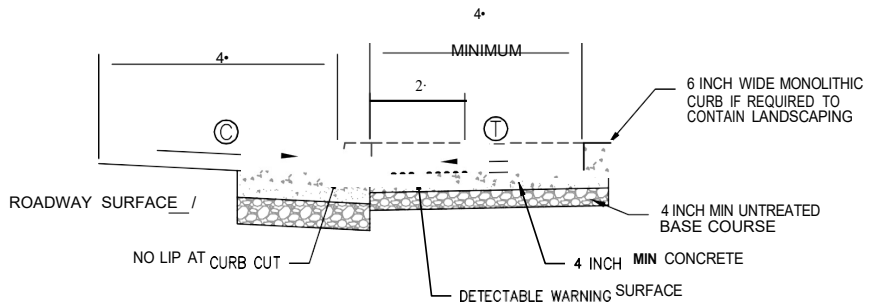

**SECTION A-A**

SLOPE TABLE			
ITEM	MAX. RUNNING SLOPE *	MAX CROSS SLOPE *	
Ⓣ	TURNING SPACE	2%	2% (c)
Ⓡ	RAMP	8.33%	2% (c)
Ⓢ	CLEAR SPACE	5%	2% (c)
Ⓢ	SIDEWALK	STREET GRADE	2%

\* RUNNING SLOPE IS IN THE DIRECTION OF PEDESTRIAN TRAVEL. CROSS SLOPE IS PERPENDICULAR TO PEDESTRIAN TRAVEL

- (a) LENGTH OF RUNNING SLOPE FOR PARALLEL RAMPS IS REQUIRED TO NOT EXCEED 15 FT.
- (b) MAINTAIN CONSISTENCY OF CLEAR SPACE RUNNING SLOPE ACROSS ENTIRE CURB CUT. WARP GUTTER PAN TO MEET REQUIRED CLEAR SPACE SLOPE AT CURB CUT.
- (c) DO NOT EXCEED THE ROADWAY GRADE FOR THE CROSS SLOPE AT CROSSWALKS WITHOUT STOP OR YIELD CONTROL AND AT MID-BLOCK CROSSWALKS.

**NOTES:**

1. DIMENSIONS SHOWN IN THE SLOPE TABLE ARE NOT SUBJECT TO CONVENTIONAL INDUSTRY TOLERANCES. CONSTRUCT SIDEWALKS AND RAMPS SUCH THAT THE MAXIMUM OR MINIMUM VALUES ARE NOT EXCEEDED. WORK THAT EXCEEDS THOSE VALUES WILL NOT BE ACCEPTED.
2. PROVIDE DETECTABLE WARNING SURFACE FOR FULL WIDTH OF CURB CUT.
3. LOCATE DETECTABLE WARNING SURFACE SO THE CORNERS NEAREST THE STREET ARE WITHIN 1 INCH OF THE BACK OF CURB.
4. RAMP GRADE BREAK MUST BE PERPENDICULAR TO THE RUNNING SLOPE.
5. CLEAR SPACE AND TURNING SPACE SIZE: 4 FT MIN. X 4 FT MIN.
6. CROSS WALK DELINEATION IF REQUIRED TO BE SHOWN ON PROJECT STRIPING PLAN.

SANTA CLARA CITY PUBLIC SERVICES DEPARTMENT

REVISIONS		
DATE	DESCRIPTION	BY

**PEDESTRIAN RAMP DETAILS**

STANDARD DWG. NO.	
121	1 OF 1
APPROVED: FEB 8 2023	
DATE: DEC 2022	BY: LB



## RESIDENTIAL STANDARD

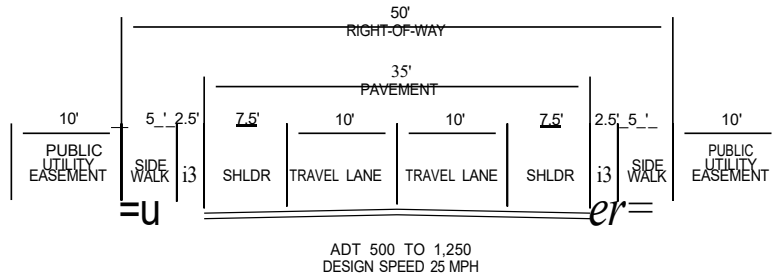

## MINOR COLLECTOR

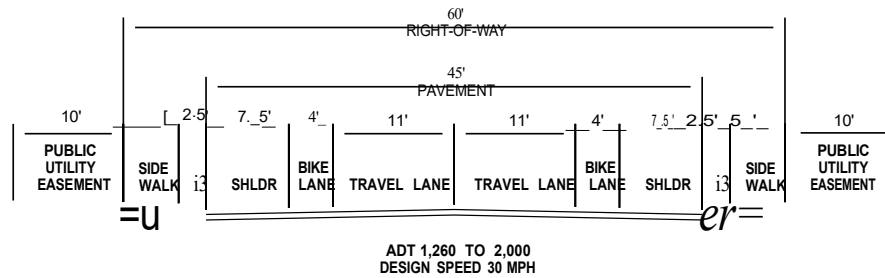

REVISIONS			SANTA CLARA CITY PUBLIC SERVICES DEPARTMENT		STANDARD DWG. NO.	
DATE	DESCRIPTION	BY	<b>STANDARD ROAD CROSS SECTIONS</b>		140-8	1 OF 1
					APPROVED: FEB 8 2023	
					DATE: DEC 2022	BY: LB

# MAJOR COLLECTOR

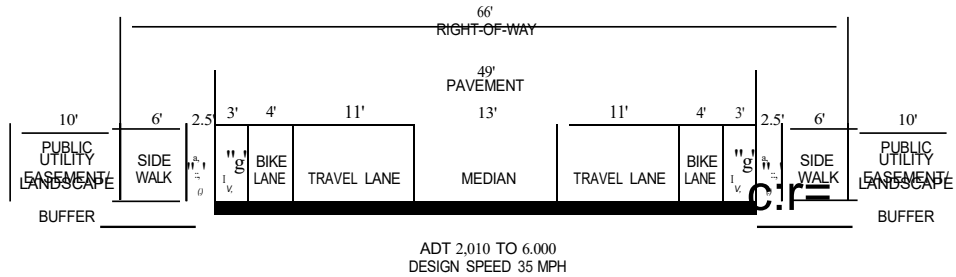

# MINOR ARTERIAL

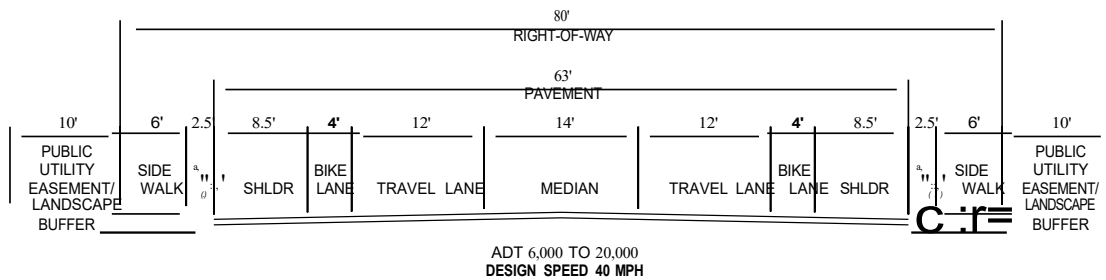

SANTA CLARA CITY PUBLIC SERVICES DEPARTMENT

REVISIONS		
DATE	DESCRIPTION	BY

## STANDARD ROAD CROSS SECTIONS

STANDARD DWG. NO.	
140-C	1 OF 1
APPROVED: FEB 8 2023	
DATE: DEC 2022	BY: LB

## MINOR ARTERIAL ALTERNATIVE

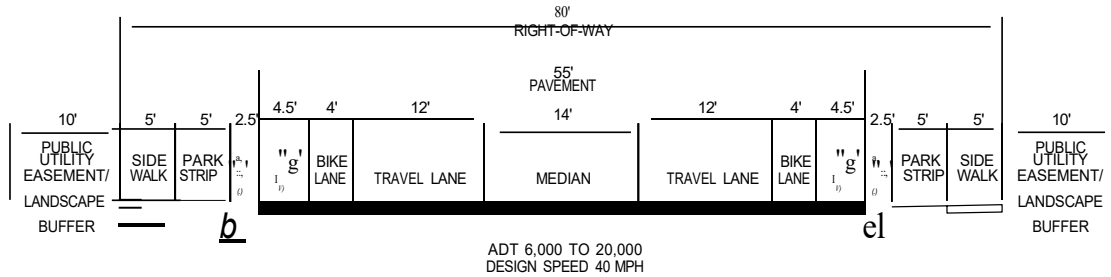

## MAJOR ARTERIAL

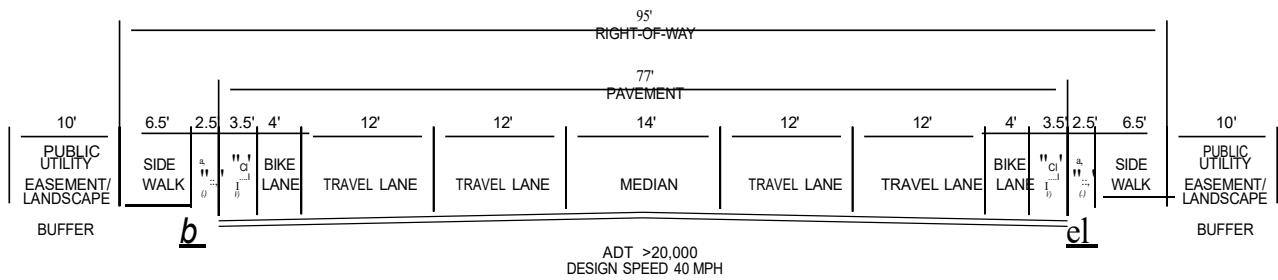

SANTA CLARA CITY PUBLIC SERVICES DEPARTMENT

REVISIONS		
DATE	DESCRIPTION	BY

### STANDARD ROAD CROSS SECTIONS

STANDARD DWG. NO.	
140-D	1 OF 1
APPROVED: FEB B 2023	
DATE: DEC 2022	BY: LB

# COMMERCIAL LOCAL

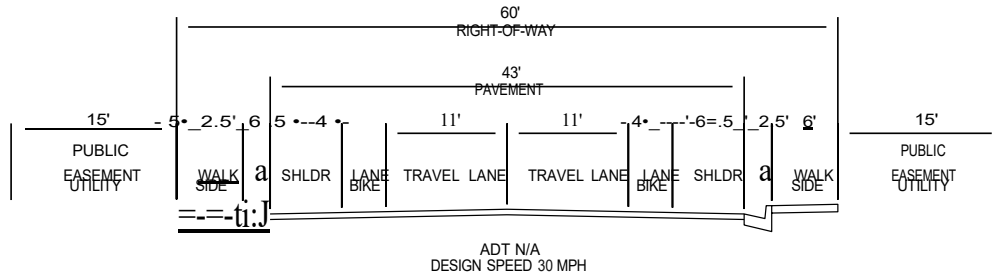

# INDUSTRIAL LOCAL

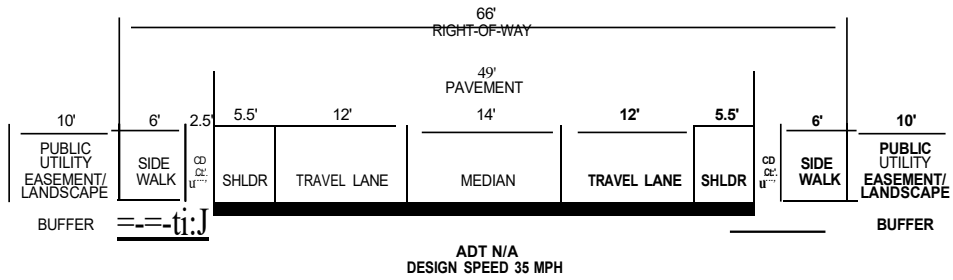

SANTA CLARA CITY PUBLIC SERVICES DEPARTMENT

REVISIONS		
DATE	DESCRIPTION	BY

## STANDARD ROAD CROSS SECTIONS

STANDARD DWG. NO.	
140-E	1 OF 1
APPROVED: FEB 8 2023	
DATE: DEC 2022	BY: LB

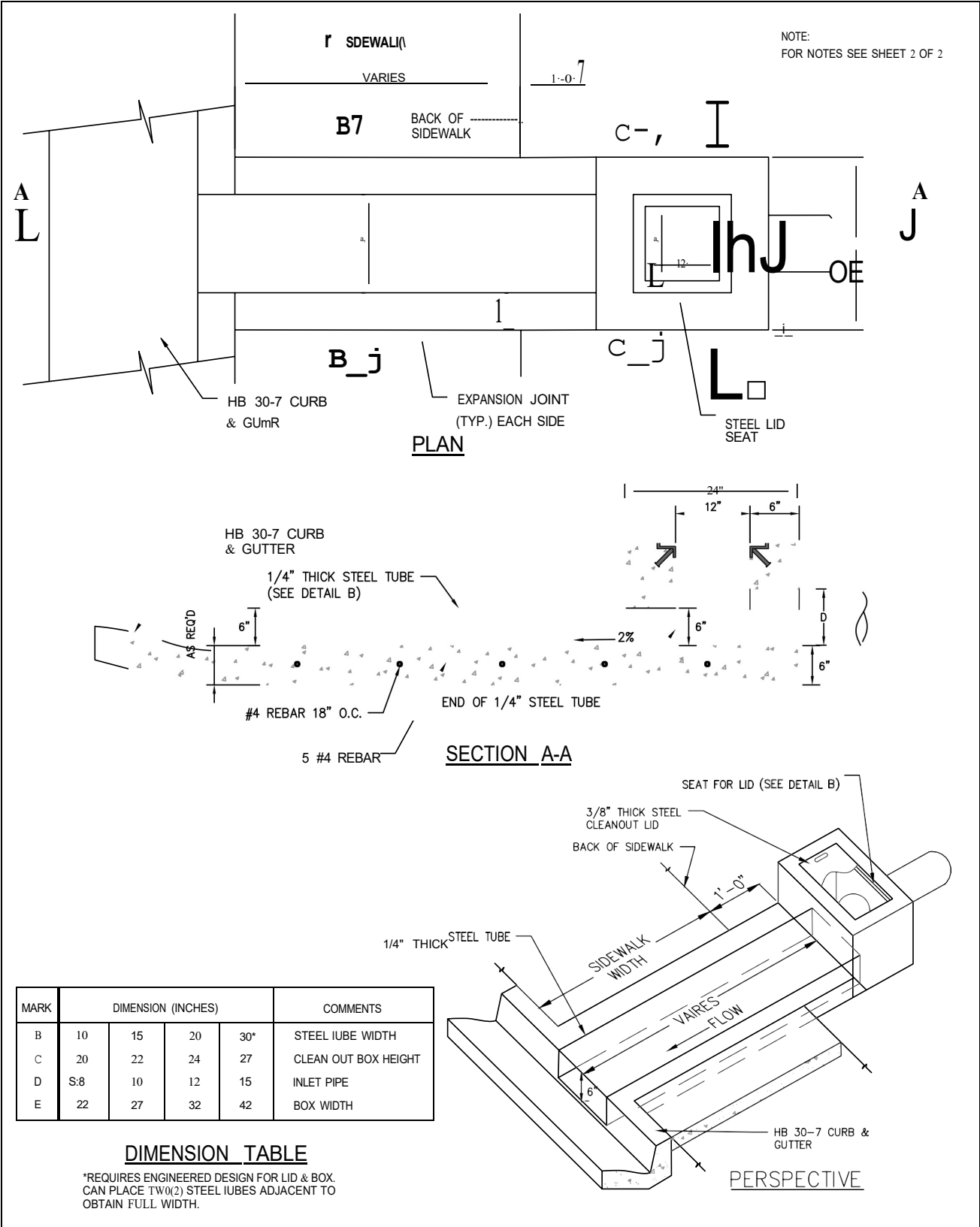

NOTE:  
FOR NOTES SEE SHEET 2 OF 2

**PLAN**

**SECTION A-A**

**PERSPECTIVE**

MARK	DIMENSION (INCHES)				COMMENTS
	B	C	D	E	
B	10	15	20	30*	STEEL TUBE WIDTH
C	20	22	24	27	CLEAN OUT BOX HEIGHT
D	S:8	10	12	15	INLET PIPE
E	22	27	32	42	BOX WIDTH

**DIMENSION TABLE**

\*REQUIRES ENGINEERED DESIGN FOR LID & BOX. CAN PLACE TWO (2) STEEL TUBES ADJACENT TO OBTAIN FULL WIDTH.

SANTA CLARA CITY PUBLIC SERVICES DEPARTMENT

REVISIONS		
DATE	DESCRIPTION	BY

**SIDEWALK DRAINAGE STRUCTURE**

STANDARD DWG. NO.	
204	1 OF 2
APPROVED: FEB 8 2023	
DATE: DEC 2022	BY: LB



NOTE:  
STEEL TUBE TO BE FLUSH WITH CONCRETE SIDEWALK.

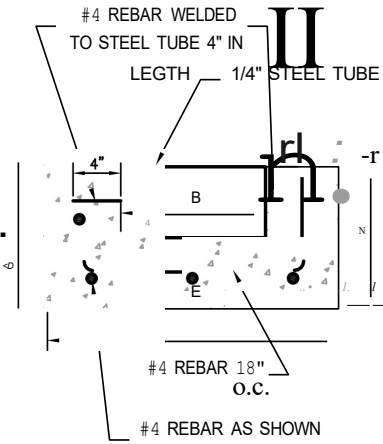

**SECTION B-B**

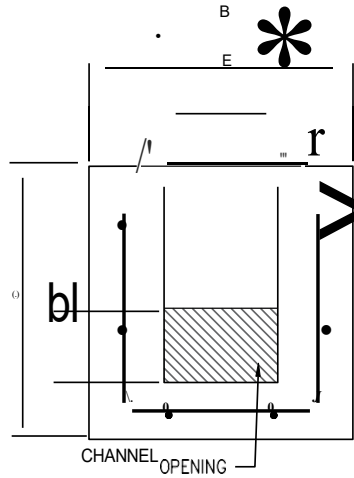

**SECTION C-C**

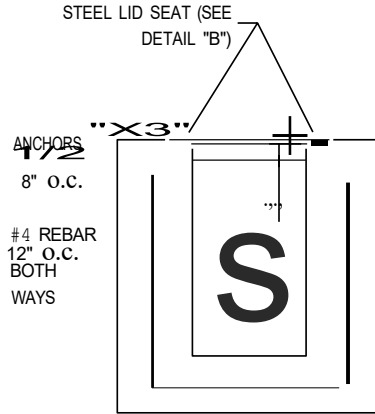

**SECTION D-D**

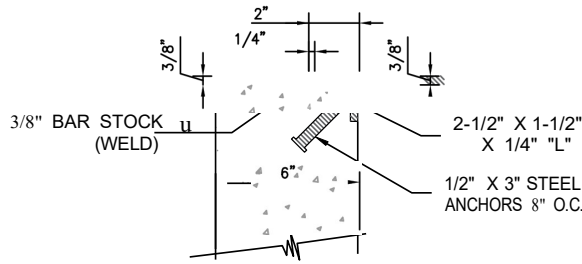

**DETAIL B**

MARK	DIMENSION (INCHES)				COMMENTS
B	10	15	20	30*	STEEL TUBE WIDTH
C	20	22	24	27	CLEAN OUT BOX HEIGHT
D	S:8	10	12	15	INLET PIPE
E	22	27	32	42	BOX WIDTH

**DIMENSION TABLE**

\*REQUIRES ENGINEERED DESIGN FOR LID & BOX. CAN PLACE 1W0(2) STEEL TUBES ADJACENT TO OBTAIN FULL WIDTH.

**NOTES:**

1. ALL REBAR SHALL HAVE 2" MIN. CLEARANCE
2. STEEL TUBE(S) SHALL BE FLUSH WITH CONCRETE.
3. BOX DIMENSION BASE UPON INLET PIPE SIZE "D"
4. ALL STEEL SHALL BE GRADE 60.
5. LID FOR CLEANOUT BOX SHALL HAVE 1-4 INCH X 1" SLOT FOR LIFTING. LID MAY BE SMOOTH OR DIAMOND PLATE STEEL.
6. 1/4" STEEL TUBES ARE STANDARD FOR SIZES UP TO 12" IN WIDTH. LARGER SIZES TO BE ORDERED. ALL TUBES TO BE CUT IN LENGTH TO MEET SIDEWALK LENGTH PLUS 1'-6"
7. STANDARD REBAR SHALL NOT BE USED FOR STEEL ANCHORS
8. ALL EXTERIOR EDGES OF CLEANOUT BOX TO HAVE 3/4" TO 1" CHAMFER (NOT SHOWN IN DETAILS FOR CLARITY)
9. STEEL LIDS AND SEAT TO BE PAINTED GREY IN ACCORDANCE WITH CITY STANDARDS.
10. #4 REBAR WELDED TO STEEL TUBES SHALL BE SPACED 18" O.C. FOR LENGTH OF TUBE(S).

SANTA CLARA CITY PUBLIC SERVICES DEPARTMENT

REVISIONS		
DATE	DESCRIPTION	BY

**SIDEWALK DRAINAGE STRUCTURE**

STANDARD DWG. NO.	
204	2 OF 2
APPROVED: FEB 8 2023	
DATE: DEC 2022	BY: LB

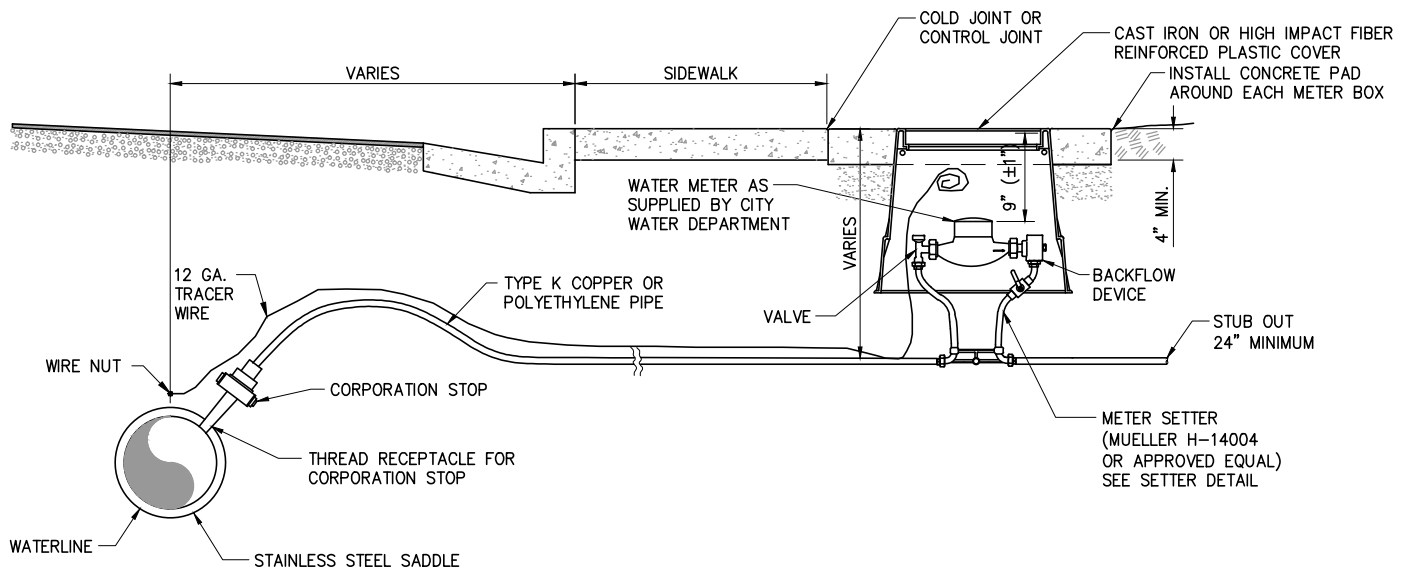

**NOTES:**

1. ALL TRENCH EXCAVATION AND COMPACTION SHALL BE IN ACCORDANCE WITH STANDARD SPECIFICATIONS.
2. METER BOX SHALL BE RATED FOR H-20 LOADING IN TRAFFIC AREAS.
3. A "W" SHALL BE SCRIBED IN THE TOP OF CURB.
4. FOR SERVICES LARGER THAN 3/4", CONTACT WATER DEPARTMENT.

SANTA CLARA CITY PUBLIC SERVICES DEPARTMENT

REVISIONS		
DATE	DESCRIPTION	BY
APR 2012	MISC. NOTES	MJW

3/4" WATER SERVICE CONNECTION & METER

STANDARD DWG. NO.	
305	1 OF 1
APPROVED:	
DATE: OCT 2008	BY: TE

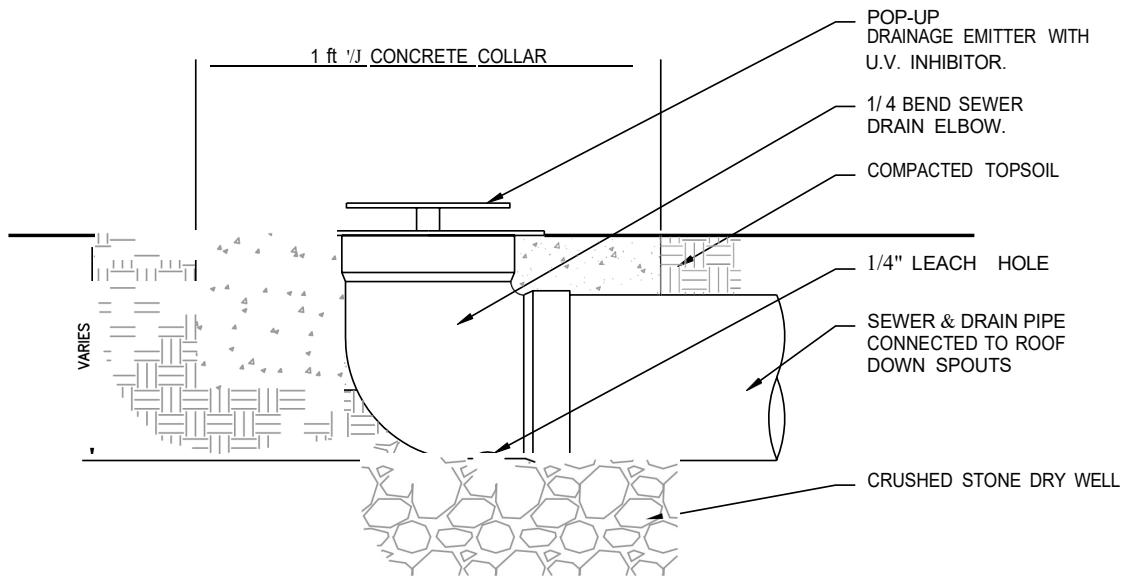

**SECTION**

SANTA CLARA CITY PUBLIC SERVICES DEPARTMENT

REVISIONS		
DATE	DESCRIPTION	BY

**YARD DRAIN TERMINATION**

STANDARD DWG. NO.	
413	1 OF 1
APPROVED: FEB 8 2023	
DATE: JAN 2023	BY: LB